

F35-ASL1

User's Manual

Revision: 1.0
Release Date: March 05, 2025

Trademark:

* Specifications and Information contained in this documentation are furnished for information use only, and are subject to change at any time without notice, and should not be construed as a commitment by manufacturer.

TABLE OF CONTENT

Environmental Protection and Safety Announcement.....	4
China RoHS Requirements (CN)	5
China RoHS Requirements (EN).....	6
User's Notice	7
Manual Revision Information	7
Packing List	7
Chapter 1 Introduction of the Motherboard.....	8
1-1 Specifications	8
Ordering Information.....	10
1-2 Block Diagram.....	12
1-3 Dimension	13
1-4 I/O Placement.....	14
1-5 Motherboard Placement.....	15
1-6 Jumper Positions.....	17
Chapter 2 Hardware Information.....	18
2-1 List of Jumpers	18
2-2 Jumper Settings.....	19
2-3 List of Connectors	24
2-4 Connector Settings	26
2-5 Maximum Voltage & Current Limit.....	44
Chapter 3 Introducing BIOS	45
3-1 Entering Setup.....	45
3-2 BIOS Menu Screen	46
3-3 Function Keys	46
3-4 Getting Help.....	47
3-5 Menu Bars.....	47
3-6 Main Menu	48
3-7 Advanced Menu	49
3-8 Chipset Menu.....	61

3-9 Security Menu	64
3-10 Boot Menu	66
3-11 Save & Exit Menu	67
Appendix A	68
Appendix B	69
I/O Address Map	69
Memory Address Map.....	72
IRQ Mapping Chart.....	74

Environmental Protection and Safety Announcement

- Do not dispose this electronic device into the trash while discarding. To minimize pollution and ensure environment protection of mother earth, please recycle.
- Avoid the dusty, humidity and temperature extremes. Do not place the product in any area where it may become wet.
- Generally speaking, dramatic changes in temperature may lead to contact malfunction and crackles due to constant thermal expansion and contraction from the welding spots' that connect components and PCB. Computer should go through an adaptive phase before it boots when it is moved from a cold environment to a warmer one to avoid condensation phenomenon. These water drops attached on PCB or the surface of the components can bring about phenomena as minor as computer instability resulted from corrosion and oxidation from components and PCB or as major as short circuit that can burn the components. Suggest starting the computer until the temperature goes up.
- The increasing temperature of the capacitor may decrease the life of computer. Using the close case may decrease the life of other device because the higher temperature in the inner of the case.

China RoHS Requirements (CN)

产品中有毒有害物质或元素名称及含量

Main Board/ Daughter Board/ Backplane

部件名称	有毒有害物质或元素					
	铅 (Pb)	汞 (Hg)	镉 (Cd)	六价铬 (Cr(VI))	多溴联苯 (PBB)	多溴二苯醚 (PBDE)
印刷电路板 及其电子组件	X	X	○	○	○	○
外部信号 连接器及线材	X	X	○	○	○	○

○: 表示该有毒有害物质在该部件所有均质材料中的含量均在

SJ/T11363-2006 标准规定的限量要求以下。

X: 表示该有毒有害物质至少在该部件的某一均质材料中的含量超出

SJ/T 11363-2006 标准规定的限量要求。

备注: 此产品所标示之环保使用期限,系指在一般正常使用状况下。

China RoHS Requirements (EN)

Poisonous or Hazardous Substances or Elements in Products

Main Board/ Daughter Board/ Backplane

Component	Poisonous or Hazardous Substances or Elements					
	Lead (Pb)	Mercury (Hg)	Cadmium (Cd)	Hexavalent Chromium (Cr(VI))	Polybrominated Biphenyls (PBB)	Polybrominated Diphenyl Ethers (PBDE)
PCB & Other Components	X	X	O	O	O	O
Wires & Connectors for External Connections	X	X	O	O	O	O

O: The quantity of poisonous or hazardous substances or elements found in each of the component's parts is below the SJ/T 11363-2006-stipulated requirement.

X: The quantity of poisonous or hazardous substances or elements found in at least one of the component's parts is beyond the SJ/T 11363-2006-stipulated requirement.

Note: The Environment Friendly Use Period as labeled on this product is applicable under normal usage only

User's Notice

COPYRIGHT OF THIS MANUAL BELONGS TO THE MANUFACTURER. NO PART OF THIS MANUAL, INCLUDING THE PRODUCTS AND SOFTWARE DESCRIBED IN IT MAY BE REPRODUCED, TRANSMITTED OR TRANSLATED INTO ANY LANGUAGE IN ANY FORM OR BY ANY MEANS WITHOUT WRITTEN PERMISSION OF THE MANUFACTURER.

THIS MANUAL CONTAINS ALL INFORMATION REQUIRED TO USE THIS MOTHER-BOARD SERIES AND WE DO ASSURE THIS MANUAL MEETS USER'S REQUIREMENT BUT WILL CHANGE, CORRECT ANY TIME WITHOUT NOTICE. MANUFACTURER PROVIDES THIS MANUAL "AS IS" WITHOUT WARRANTY OF ANY KIND, AND WILL NOT BE LIABLE FOR ANY INDIRECT, SPECIAL, INCIDENTAL OR CONSEQUENTIAL DAMAGES (INCLUDING DAMAGES FOR LOSS OF PROFIT, LOSS OF BUSINESS, LOSS OF USE OF DATA, INTERRUPTION OF BUSINESS AND THE LIKE).

PRODUCTS AND CORPORATE NAMES APPEARING IN THIS MANUAL MAY OR MAY NOT BE REGISTERED TRADEMARKS OR COPYRIGHTS OF THEIR RESPECTIVE COMPANIES, AND THEY ARE USED ONLY FOR IDENTIFICATION OR EXPLANATION AND TO THE OWNER'S BENEFIT, WITHOUT INTENT TO INFRINGE.

Manual Revision Information

Reversion	Revision History	Date
1.0	First Edition	March 05, 2025

Packing List

Part Number	Description	QTY per Board
F35-ASL1	F35-ASL1 MB	1
HCS3XXMHT03S-5F	Flat type Heatsink (assembled)	1
HCS376MHT01S-F	CPU plate (assembled)	1
G01-SATA3-BL-1F	SATA cable, 50cm	1
G01-PW4PS2S-322-1F	SATA Power Y cable, 5.0pitch for 32cm, 2.54pitch for 20cm	1
G01-COM-H2M22-1F	COM Port Cable, 22cm, Pitch 2.0	2

Chapter 1 Introduction of the Motherboard

1-1 Specifications

SYSTEM	
MB FORM FACTOR	3.5"
CPU	Onboard Intel Atom® x7433RE Processor (Formerly Amston Lake, TDP 9W) For additional compatible CPUs, please contact regional sales
MEMORY	1 x DDR5 4800MHz, Single Channel SO-DIMM, up to 32GB
BIOS	UEFI
WAKE ON LAN	Yes
WATCHDOG TIMER	255 Levels
SECURITY	TPM2.0 (dTPM, Optional)
RTC BATTERY	Lithium Battery
DIMENSION (W X D)	148.0 (W) x 102.0 (D) mm (5.8" x 4.0")
OS SUPPORT	Windows® 11 (64bit) Windows® 10 (64bit) Linux
POWER	
POWER REQUIREMENT	DC-in 12~28V
POWER ON MODE	AT / ATX (Default) Mode
CONNECTOR	Internal 2-pin Header
DISPLAY	
GPU	Intel® UHD Graphics
LVDS	1 x 24-bit Dual Channel LVDS (Max. Resolution: 1920 x 1080 @60Hz / Co-Lay eDP)
eDP	1 x INT (co-lay with LVDS)
Type C DP	1 x Type C DP1.4a (Max Resolution: 4096 x 2304@60Hz)
HDMI	1 x HDMI 2.0b (Max Resolution: 4096 x 2160@60Hz), 1 x HDMI 1.4 (Max Resolution: 4096 x 2160@30Hz)
MULTIPLE DISPLAY	Support 3 Displays
AUDIO	
CODEC	Realtek Audio Codec
COMBO	1 x Combo Audio Jack for Line-Out / Mic-In
AMPLIFIER	3W
LAN	
ETHERNET	2 x RJ45 for Intel® I226-V 2.5GbE

USB PORT	
USB	Internal Header for 4 x USB 2.0 4 x USB 2.0 1 x USB 3.2 Gen 2x1 Type-C (10Gbps) Support DP ALT Mode 1 x USB 3.2 Gen 2x1 (10Gbps, Formerly USB 3.1 Gen 2)
SERIAL PORT	
COM	Internal Header for 1 x RS-232/422/485 Internal Header for 5 x RS-232
INTERNAL I/O	
GPIO	8-Bit
SMBUS	Yes
FAN	1 x 4-pin Connector for System Fan (PWM Mode)
FRONT PANEL	HDD Active LED Power LED Power On/Off Reset
ADDITIONAL	1 x Chassis intrusion 1 x AT/ATX Mode Selection
STORAGE	
SATA	1 x SATA III 1 x SATA Power Connector
eMMC	Onboard 64GB eMMC 5.1 (optional)
EXPANSION	
M.2	1 x B-Key 3042/3052 (USB 3.2/USB 2.0) for 4G/5G Module 1 x E-Key 2230 (USB 2.0/PCIe 3.0 x1) 1 x M-Key 2280 (PCIe 3.0 x2) Support NVMe
SIM	1 x Nano SIM Card Slot
ENVIRONMENT & CERTIFICATION	
SHOCK	15G, 11ms duration
VIBRATION	1 Grms/ 5~ 500Hz/ Operation
OPERATING TEMPERATURE	-20°C ~ 60°C (-4°F ~ 140°F)
STORAGE TEMPERATURE	-20°C ~ 85°C (-4°F ~ 185°F)
OPERATING HUMIDITY	10 ~ 90% relative humidity, non-condensing
CERTIFICATION	CE/FCC Class A

Ordering Information

PART NUMBER	F35-ASL1-74330010	F35-ASL1-74330210	F35-ASL1-74330810
CPU	Intel® Atom® x7433RE Processor	Intel® Atom® x7433RE Processor	Intel® Atom® x7433RE Processor
SECURITY	Intel® PTT (fTPM)	TPM2.0 (dTPM)	TPM2.0 (dTPM)
POWER REQUIREMENT	DC-in 12~28V	DC-in 12~28V	DC-in 12~28V
GPU	Intel® UHD Graphics	Intel® UHD Graphics	Intel® UHD Graphics
LVDS	1 x LVDS/eDP	1 x LVDS/eDP	1 x LVDS/eDP
eDP	1 x eDP/LVDS	1 x eDP/LVDS	1 x eDP/LVDS
Type C DP	1 x Type C DP	1 x Type C DP	1 x Type C DP
HDMI	2 x HDMI	2 x HDMI	2 x HDMI
MULTIPLE DISPLAY	Support 3 Displays	Support 3 Displays	Support 3 Displays
ETHERNET	2 x 2.5GbE	2 x 2.5GbE	2 x 2.5GbE
USB	4 x USB 2.0	4 x USB 2.0	4 x USB 2.0
USB	1 x USB3.2 Gen 2 Type C	1 x USB3.2 Gen 2 Type C	1 x USB3.2 Gen 2 Type C
USB	1 x USB3.2 Gen 2	1 x USB3.2 Gen 2	1 x USB3.2 Gen 2
COM	1 x RS-232/422/485	1 x RS-232/422/485	1 x RS-232/422/485
COM	5 x RS-232	5 x RS-232	5 x RS-232
SATA	1 x SATA III	1 x SATA III	1 x SATA III
eMMC	–	–	eMMC 64GB
M.2	1 x B-Key 3042/3052	1 x B-Key 3042/3052	1 x B-Key 3042/3052
M.2	1 x E-Key 2230	1 x E-Key 2230	1 x E-Key 2230

M.2	1 x M-Key 2280	1 x M-Key 2280	1 x M-Key 2280
SIM	1 x Nano SIM Card Slot	1 x Nano SIM Card Slot	1 x Nano SIM Card Slot
OPERATING TEMPERATURE	-20°C ~ 60°C (-4°F ~ 140°F)	-20°C ~ 60°C (-4°F ~ 140°F)	-20°C ~ 60°C (-4°F ~ 140°F)

1-2 Block Diagram

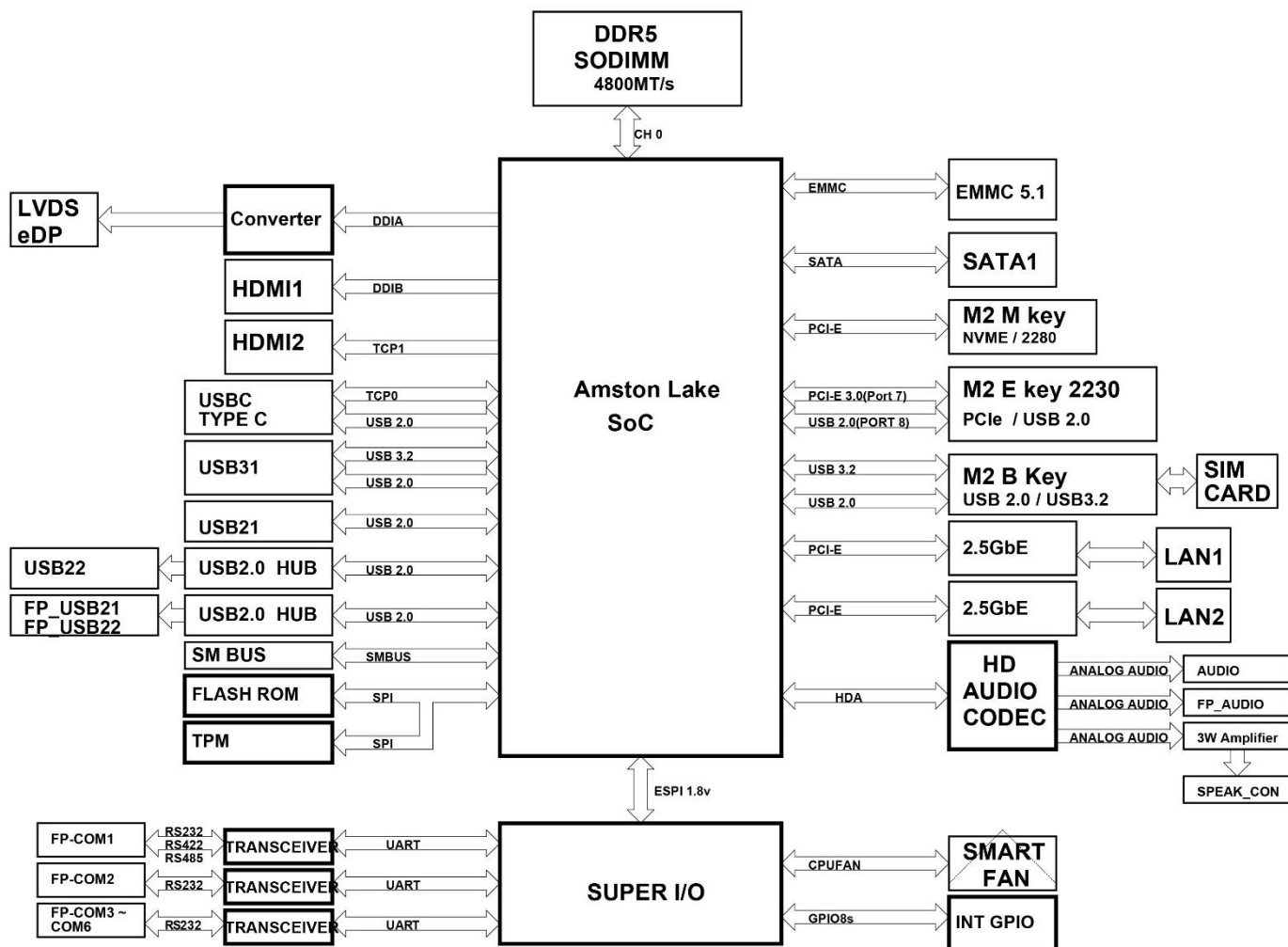

1-3 Dimension

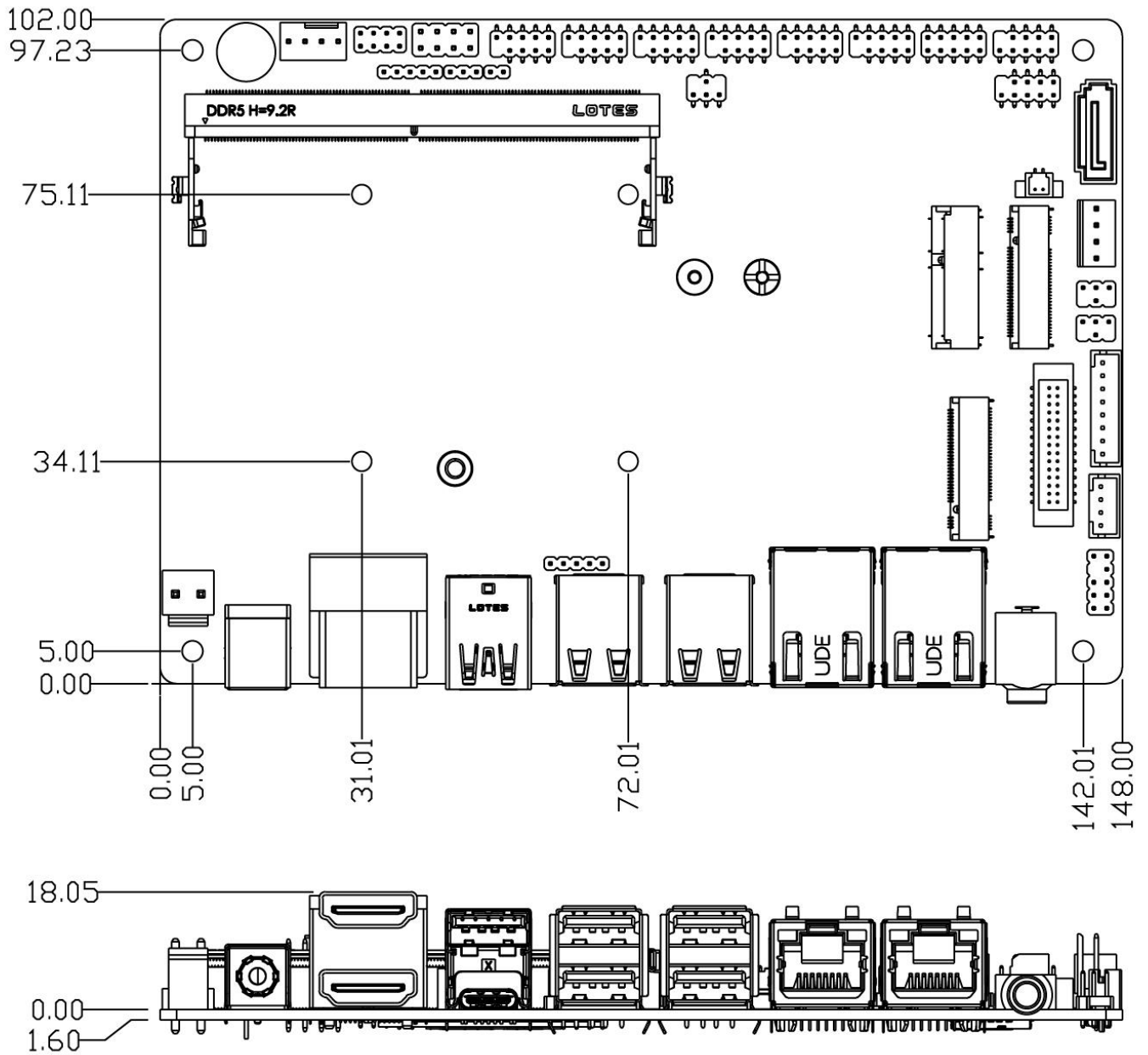

1-4 I/O Placement

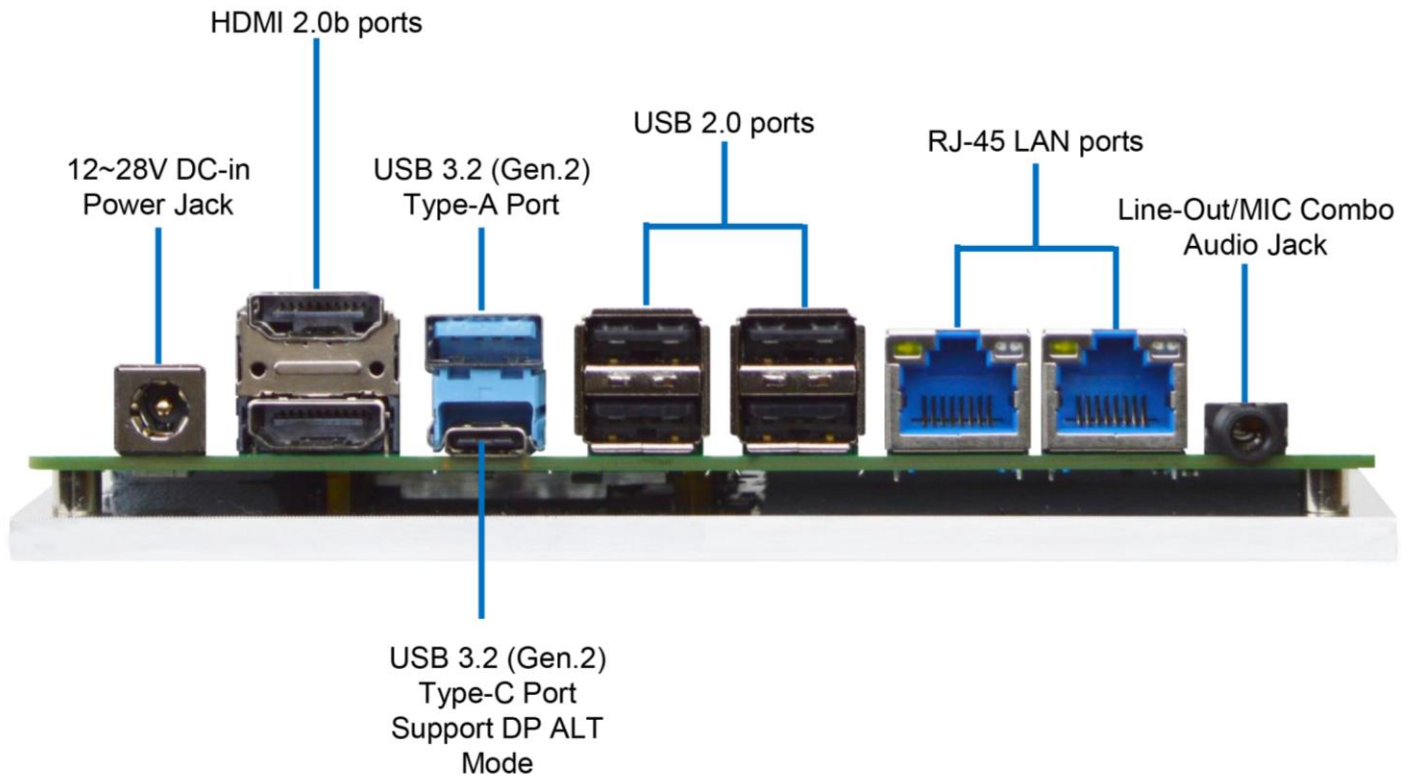

1-5 Motherboard Placement

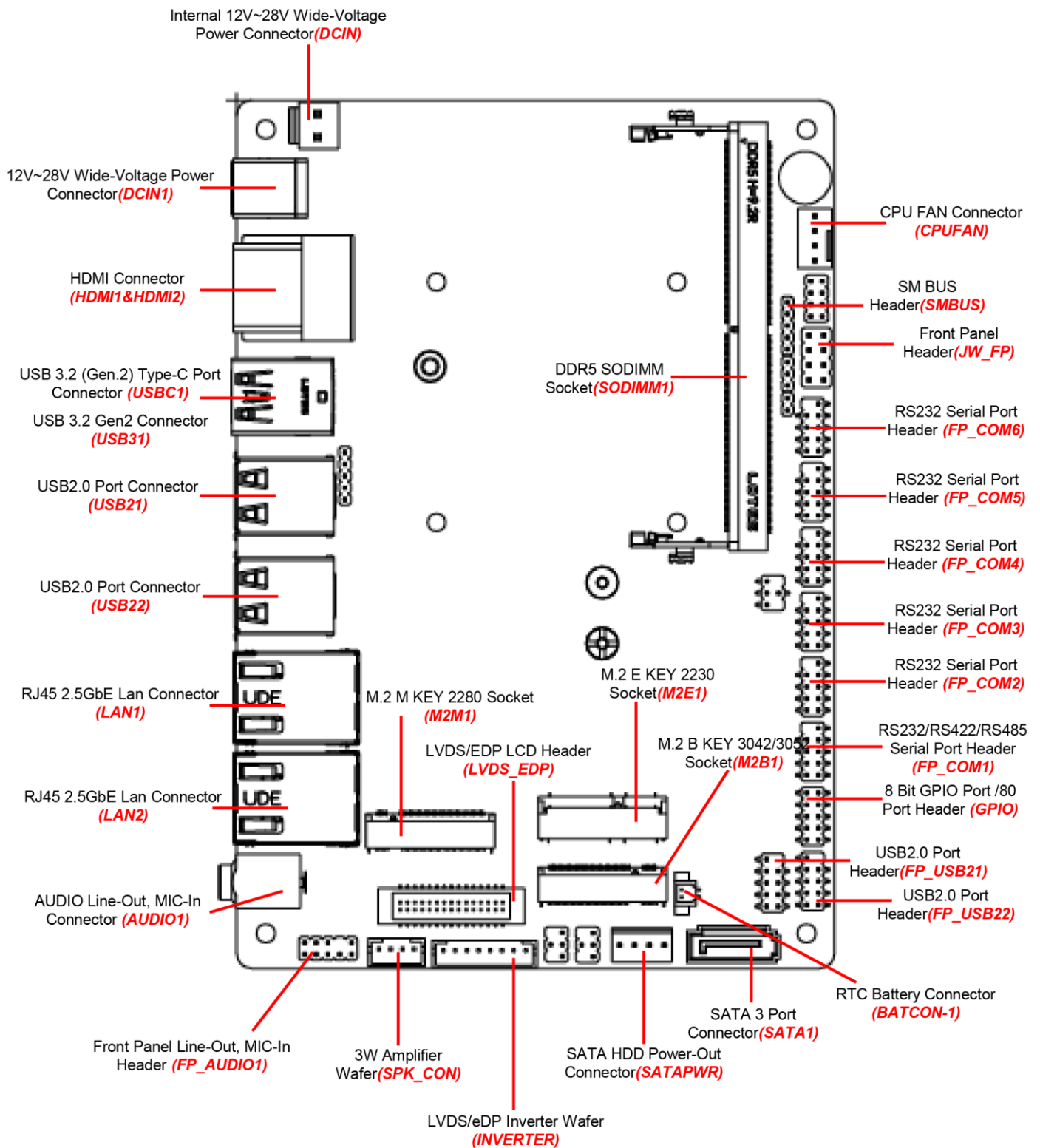

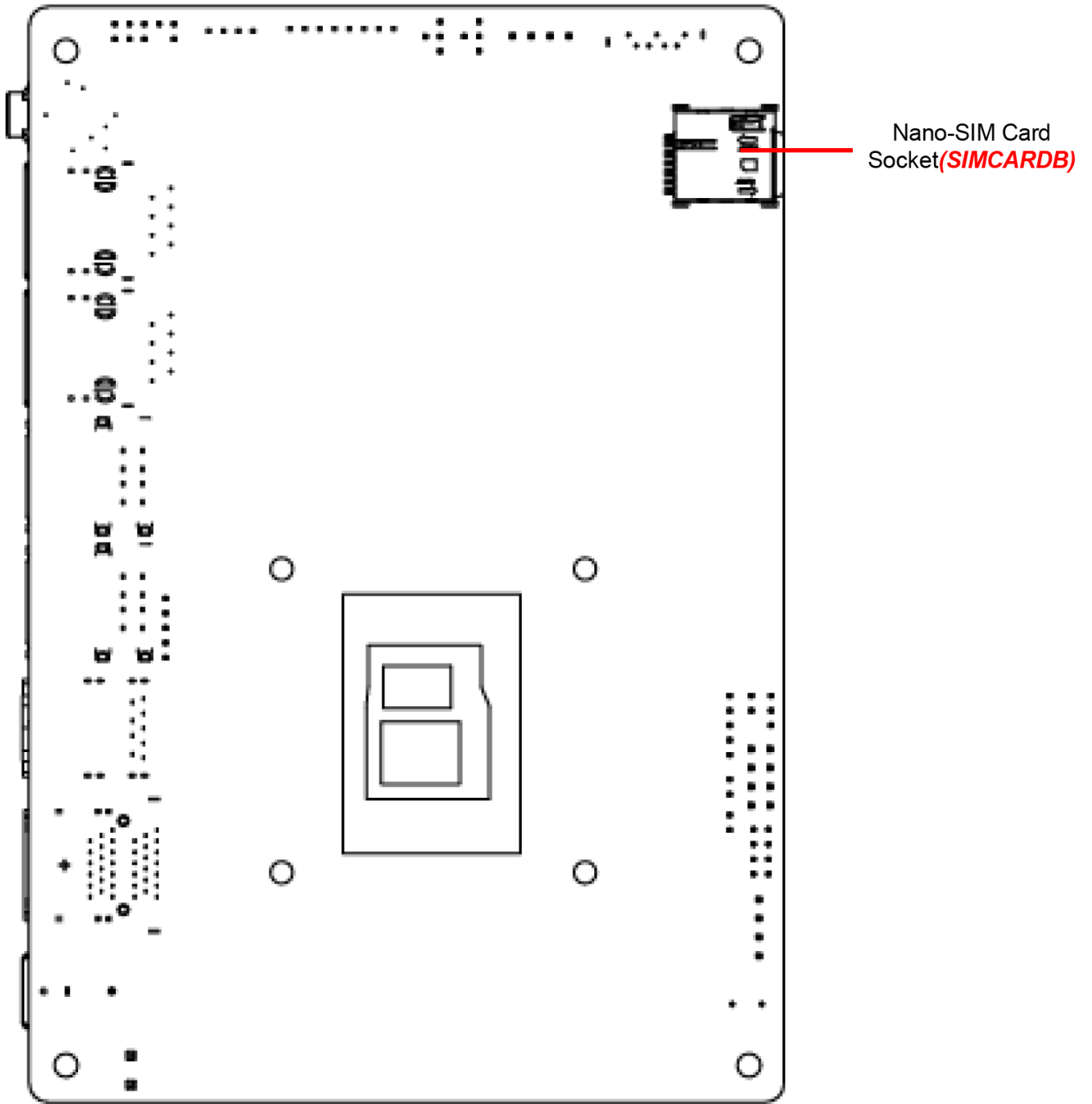

1-6 Jumper Positions

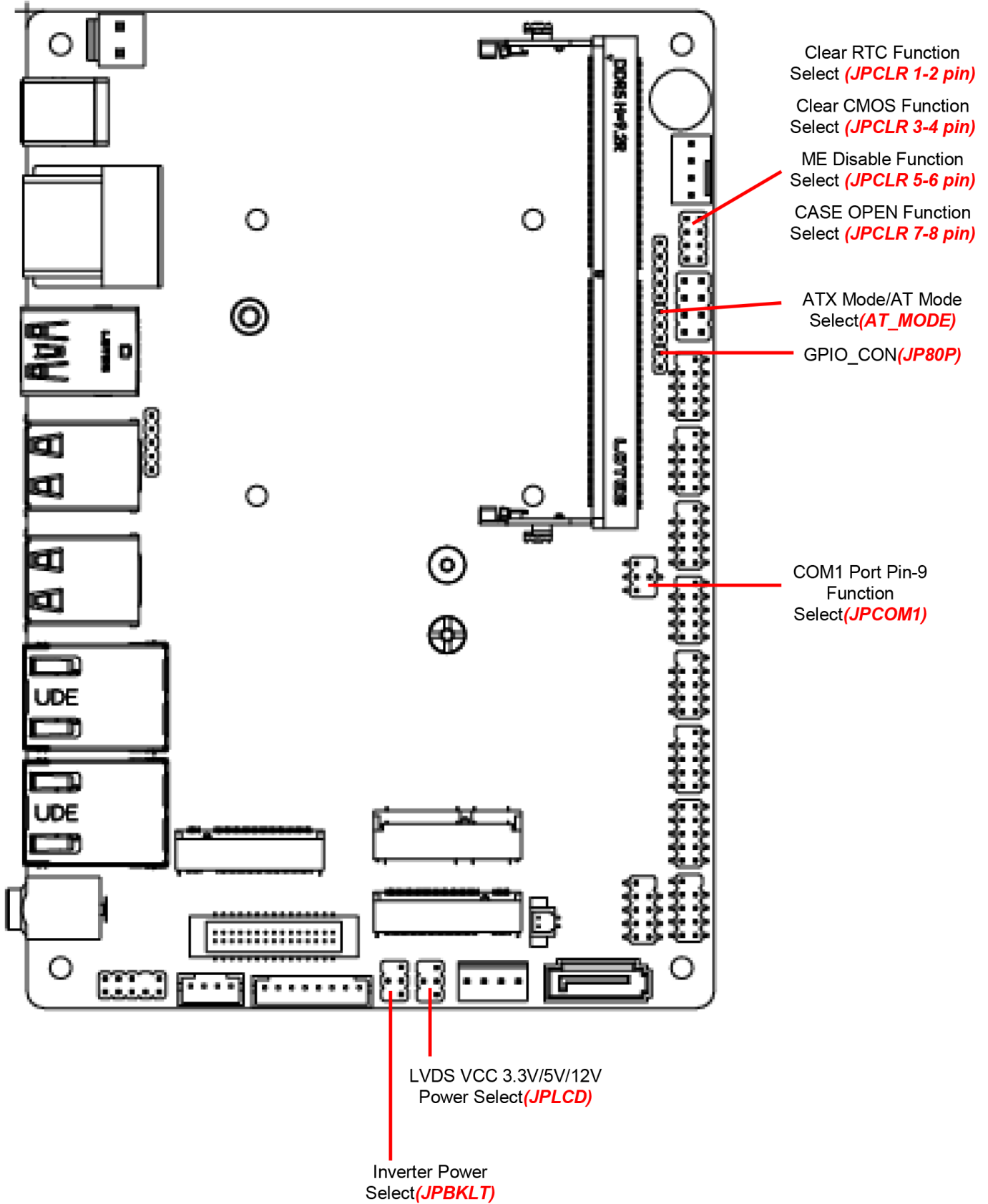

Chapter 2 Hardware Information

2-1 List of Jumpers

Please refer to the table below for all of the board's jumpers that you can configure for your application.

Location Printing	Function
JP80P	Set GPIO_CON
AT_MODE	ATX Mode / AT Mode Select
JPCOM1	COM1 Header Pin9 Select
JPLCD	LVDS Panel VCC Power Select
JPBKLT	LCD BACKLIGHT VCC Power Select
JPCLR (1-2 PIN)	Clear RTC Function Select
JPCLR (3-4 PIN)	Clear CMOS Function Select
JPCLR (5-6 PIN)	ME Disable Function Select
JPCLR (7-8 PIN)	CASE OPEN Function Select

2-2 Jumper Settings

(1) Set GPIO_CON (JP80P)

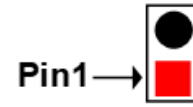
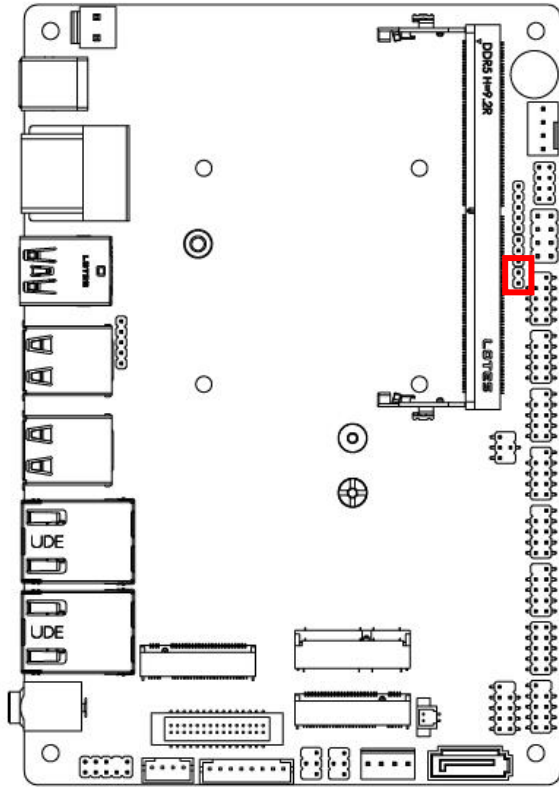

1-2 Open: GPIO= 80 Port;

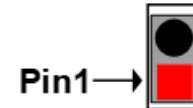

1-2 Closed: GPIO= GPIO Port

(2) ATX Mode/AT Mode Select (AT_MODE)

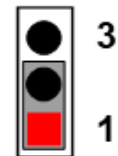
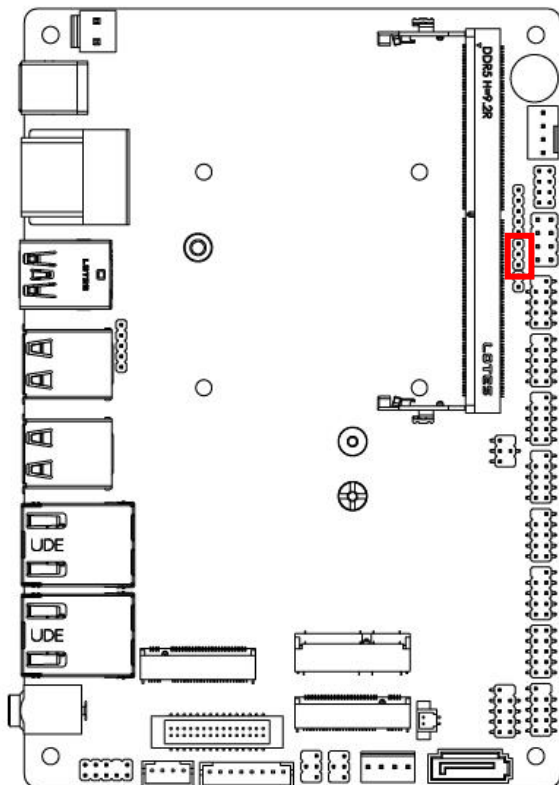

1-2 Closed: ATX Mode Selected;

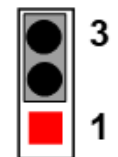

2-3 Closed: AT Mode Selected.

(3) COM1 Port Pin-9 Function Select (JPCOM1)

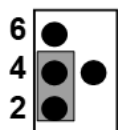
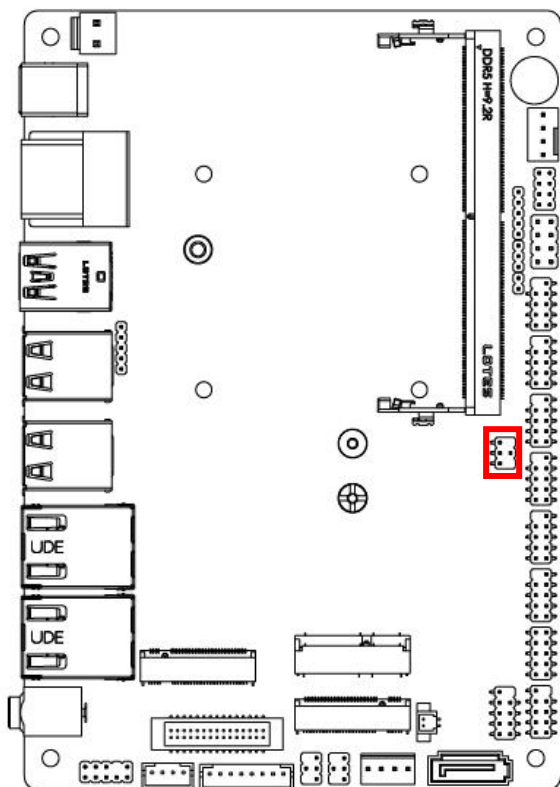

**2-4 Closed:
RI=RING**

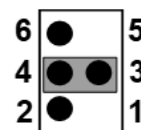

**3-4 Closed:
RI=5V**

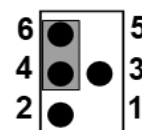

**4-6 Closed:
RI=12V**

(4) LVDS VCC 3.3V/5V/12V Power Select (JPLCD)

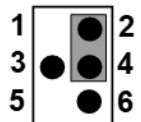
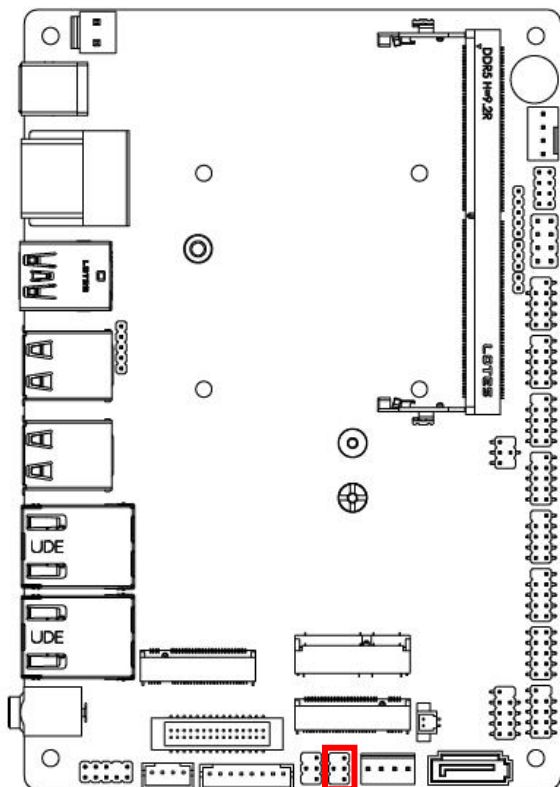

**2-4 Closed:
VCC= 3.3V**

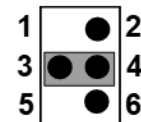

**3-4 Closed:
VCC= 5V**

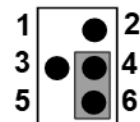

**4-6 Closed:
VCC= 12V**

(5) Inverter Power Select (JPBKLT)

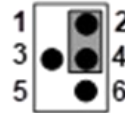
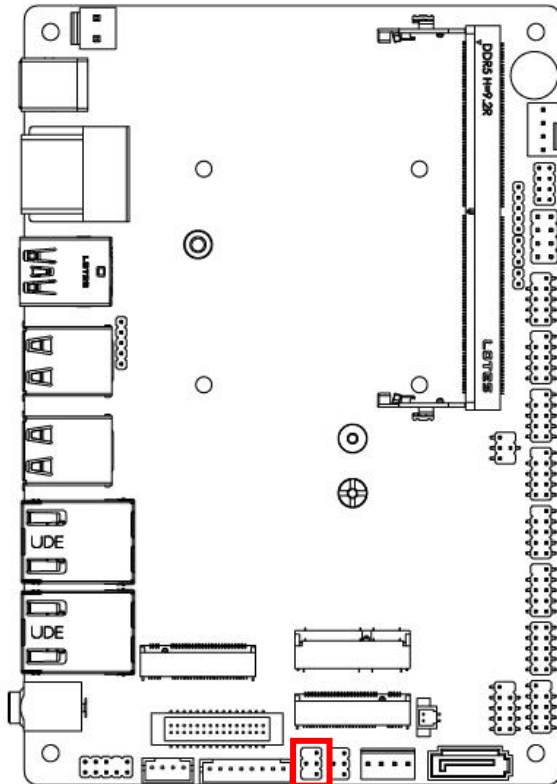

2-4 Closed:
Backlight Power
=5V

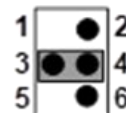

3-4 Closed:
Backlight Power
=12V

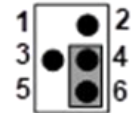

4-6 Closed:
Backlight Power
=Adapter VCC
(12V)

(6) Clear RTC Function Select (JPCLR 1-2 pin)

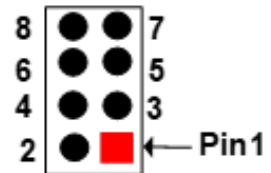
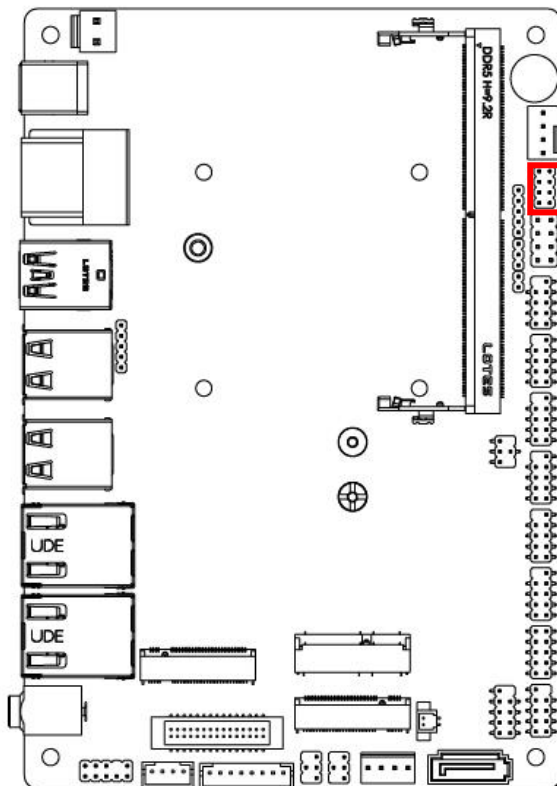

1-2 Open: Normal(Default)

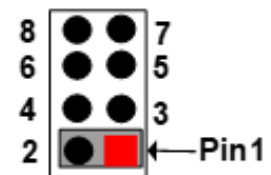

1-2 Closed: Clear RTC

(7) Clear CMOS Function Select (JPCLR 3-4 pin)

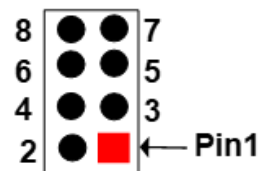
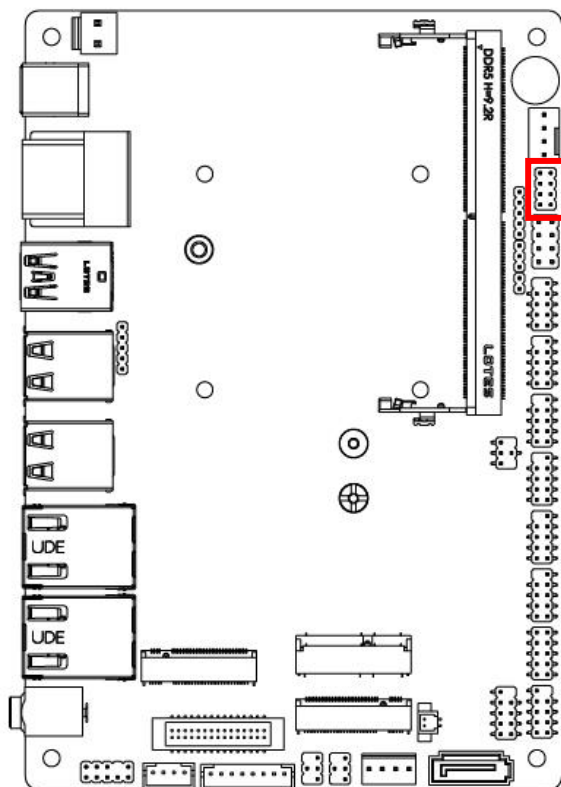

3-4 Open: Normal(Default)

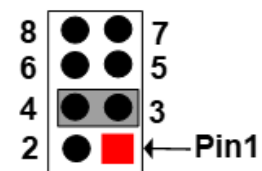

3-4 Closed: Clear CMOS

(8) ME Disable Function Select (JPCLR 5-6 pin)

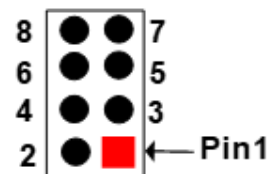
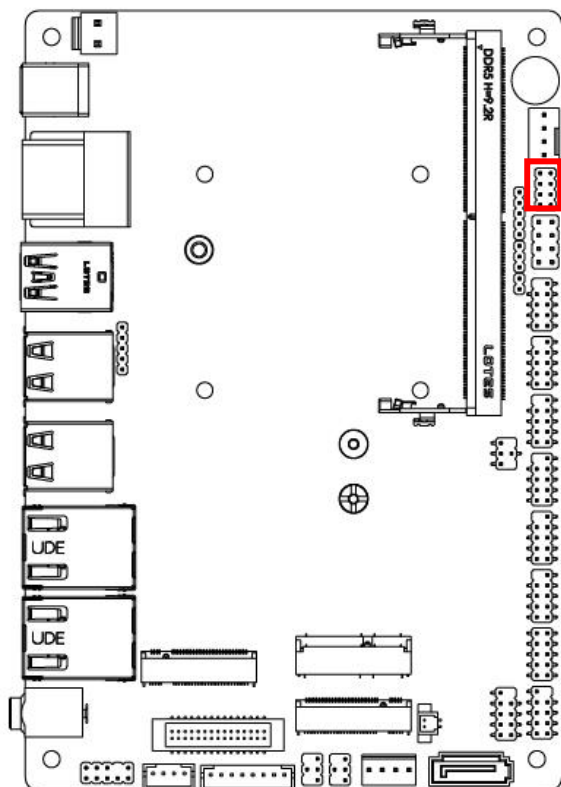

5-6 Open: Normal(Default)

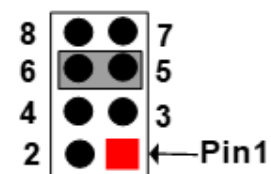

5-6 Closed: ME Disable

(9) CASE OPEN Function Select (JPCLR 7-8 pin)

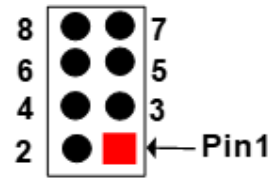
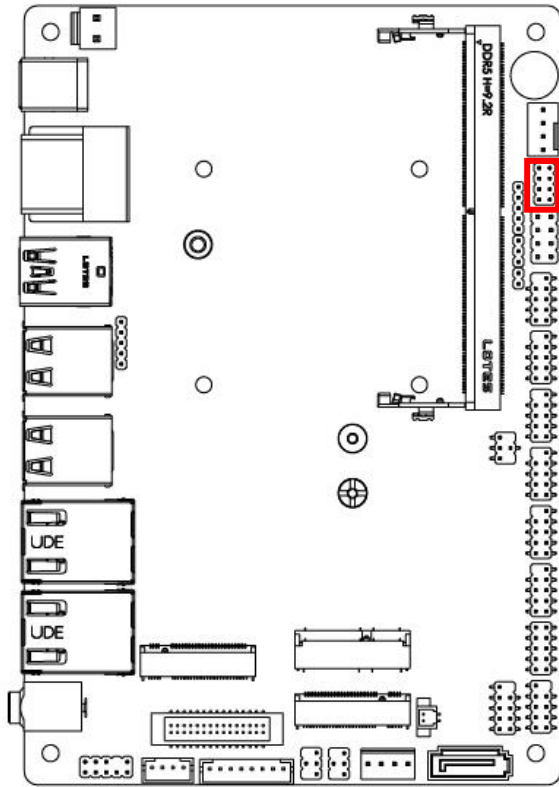

7-8 Open: Normal(Default)

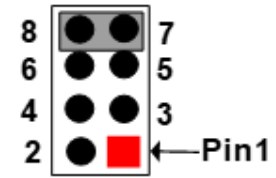

7-8 Closed: CASE OPEN

2-3 List of Connectors

Please refer to the table below for all of the board's jumpers that you can configure for your application.

Location Printing	Function
DCIN1	12V~28V Wide-Voltage Power Connector
HDMI1	HDMI Connector
HDMI2	HDMI Connector
USBC1	USB 3.2 (Gen.2) Type-C Port Connector
USB31	USB 3.2 Gen2 Connector
USB21	USB2.0 Port Connector
USB22	USB2.0 Port Connector
LAN1	RJ45 2.5GbE Lan Connector
LAN2	RJ45 2.5GbE Lan Connector
AUDIO1	AUDIO Line-Out, MIC-In Connector
DCIN	Internal 12V~28V Wide-Voltage Power Connector
CPUFAN	CPU FAN Connector
SATA1	SATA 3 Port Connector
SATAPWR	SATA HDD Power-Out Connector
BATCON-1	RTC Battery Connector
JW_FP	Front Panel Header
FP_USB21	USB2.0 Port Header
FP_USB22	USB2.0 Port Header
FP_AUDIO1	Front Panel Line-Out, MIC-In Header
SPK_CON	3W Amplifier Wafer
GPIO	8 Bit GPIO Port /80 Port Header
SMBUS	SM BUS Header
FP_COM1	RS232/RS422/RS485 Serial Port Header
FP_COM2	RS232 Serial Port Header
FP_COM3	RS232 Serial Port Header
FP_COM4	RS232 Serial Port Header
FP_COM5	RS232 Serial Port Header
FP_COM6	RS232 Serial Port Header
LVDS_EDP	LVDS/EDP LCD Header
INVERTER	LVDS/eDP Inverter Wafer
SIMCARDB	Nano-SIM Card Socket
M2M1	M.2 M KEY 2280 Socket

M2B1	M.2 B KEY 3042/3052 Socket
M2E1	M.2 E KEY 2230 Socket
SODIMM1	DDR5 SODIMM Socket

2-4 Connector Settings

(1) 12V~28V Wide-Voltage Power Connector (DCIN1)

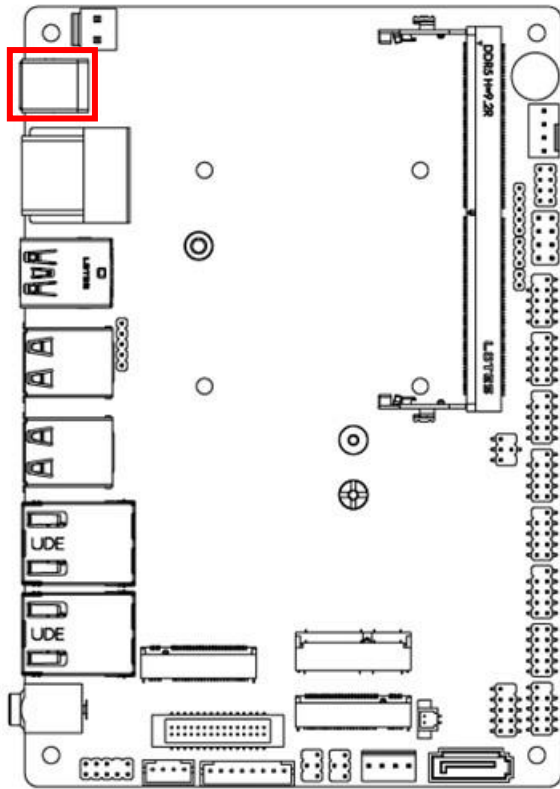

(2) HDMI Connector (HDMI1)

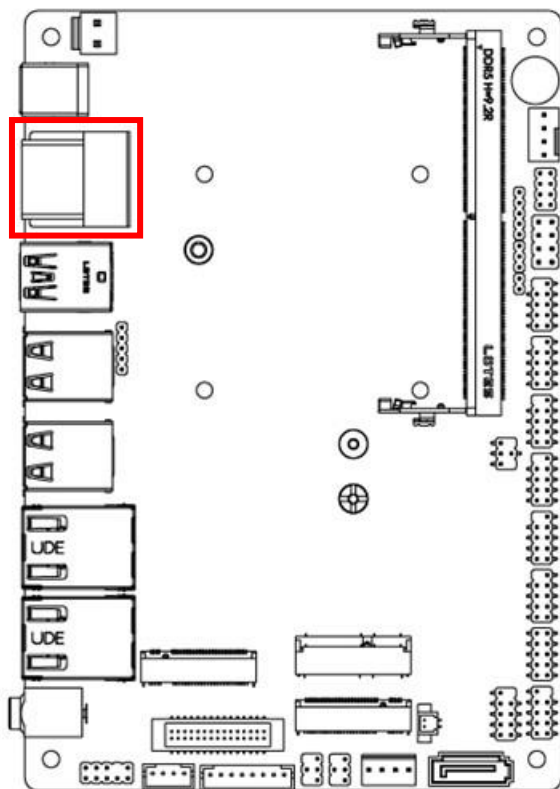

Note: Standard specifications.

(3) HDMI Connector (HDMI2)

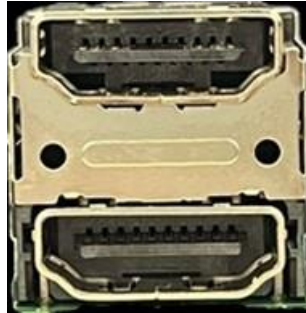
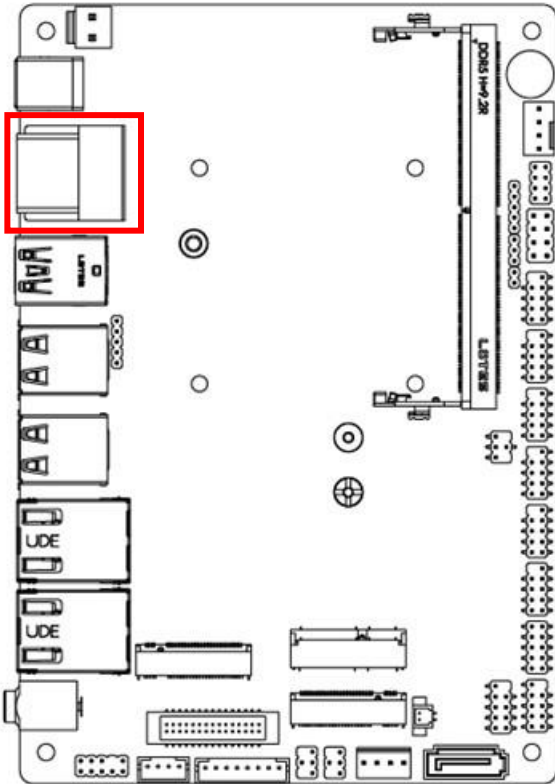

Note: Standard specifications.

(4) USB 3.2 (Gen.2) Type-C Port Connector (USBC1)

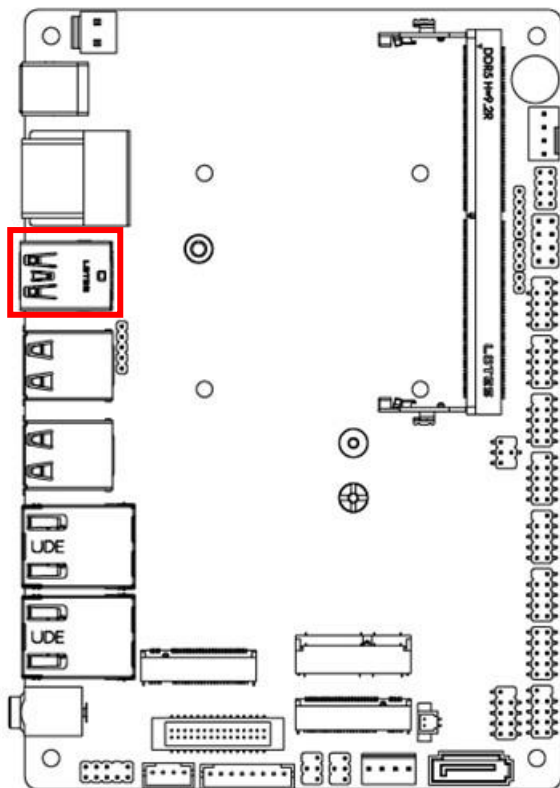

Note: Standard specifications.

(5) USB 3.2 Gen2 Connector (USB31)

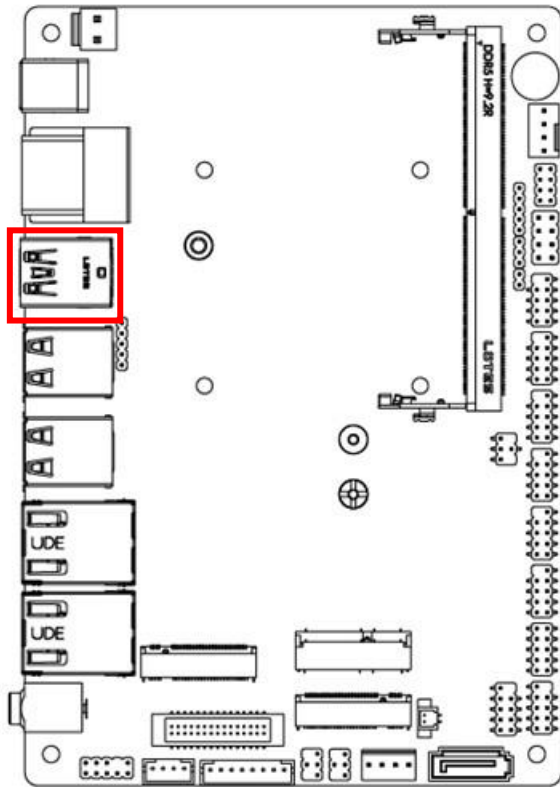

Note: Standard specifications.

(6) USB2.0 Port Connector (USB21)

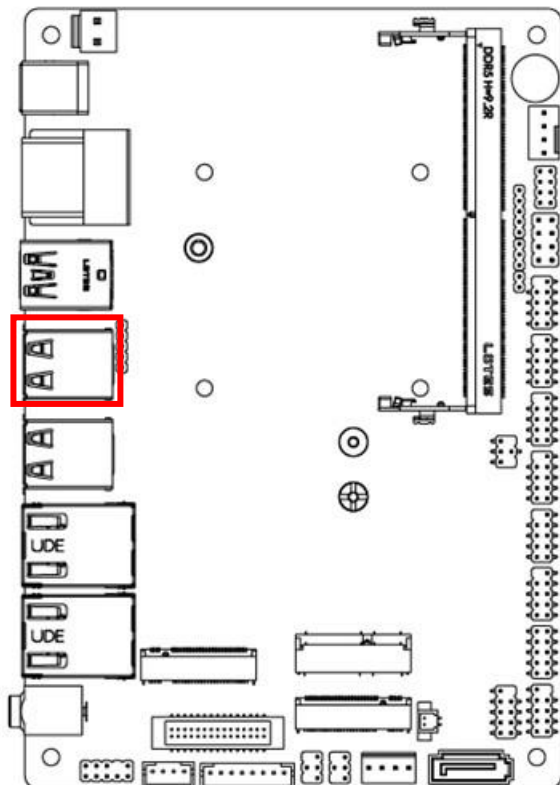

Note: Standard specifications.

(7) USB2.0 Port Connector (USB22)

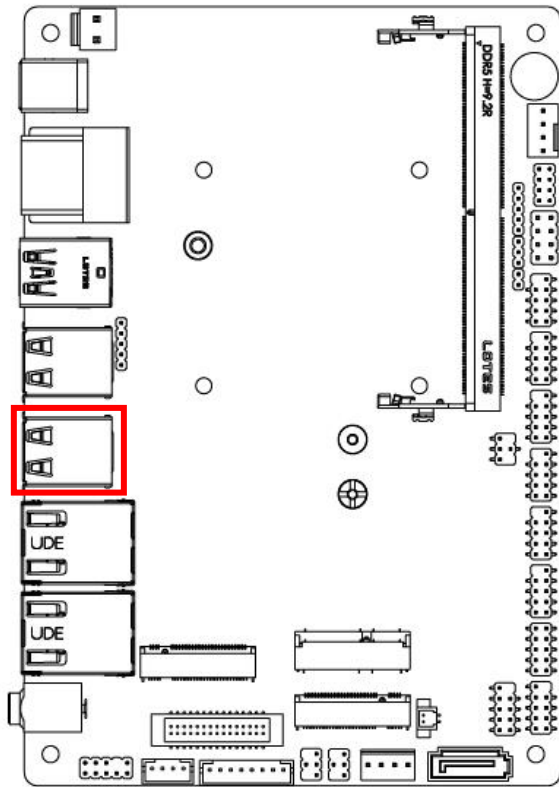

Note: Standard specifications.

(8) RJ45 2.5GbE Lan Connector (LAN1)

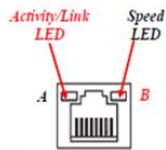
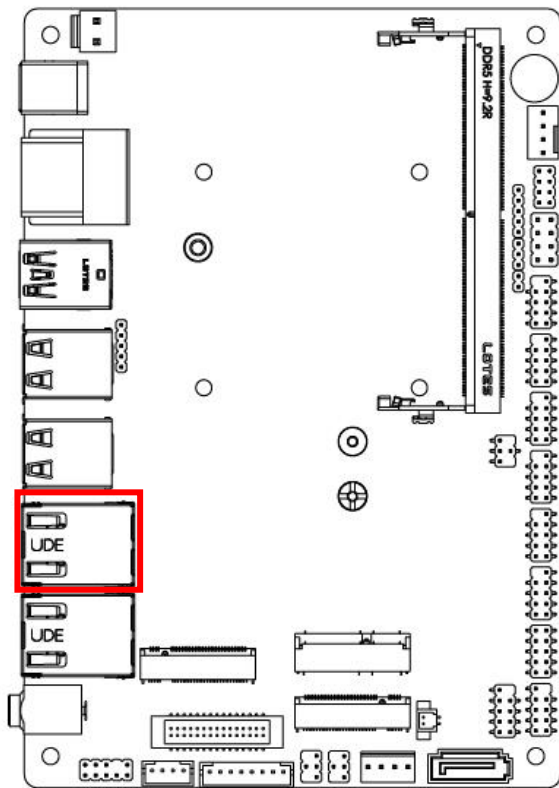

A: Activity/Link LED		B: Speed LED	
Status	Description	Status	Description
Off	No Link	Off	10/100Mbps connection
Blinking	Data Activity	Orange	1000Mbps connection
On	Link	Green	2.5Gbps connection

* **Note:** 2.5Gbps high-speed transmission rate is **only** supported over CAT 5e UTP cable.

Note: Standard specifications.

(9) RJ45 2.5GbE Lan Connector (LAN2)

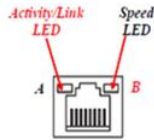
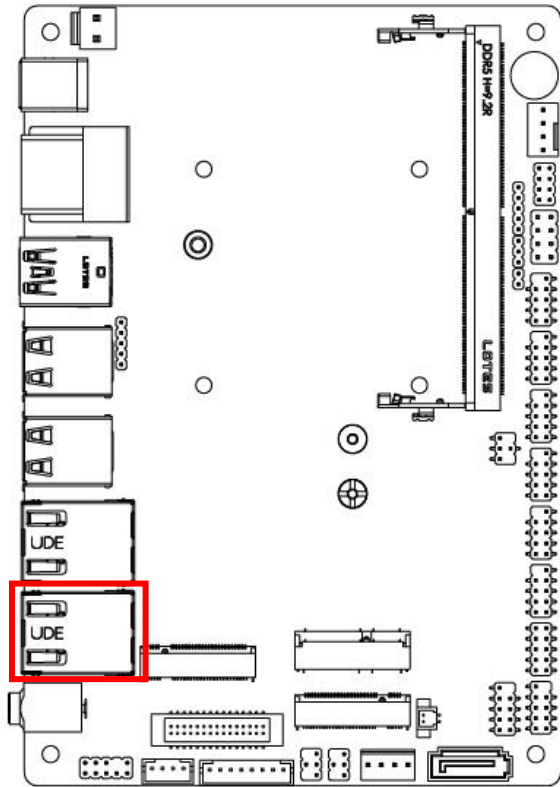

A: Activity/Link LED		B: Speed LED	
Status	Description	Status	Description
Off	No Link	Off	10/100Mbps connection
Blinking	Data Activity	Orange	1000Mbps connection
On	Link	Green	2.5Gbps connection

* Note: 2.5Gbps high-speed transmission rate is **only** supported over CAT 5e UTP cable.

Note: Standard specifications.

(10) AUDIO Line-Out, MIC-In Connector (AUDIO1)

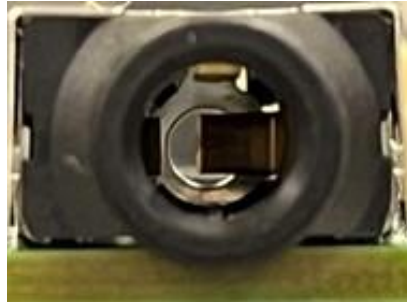
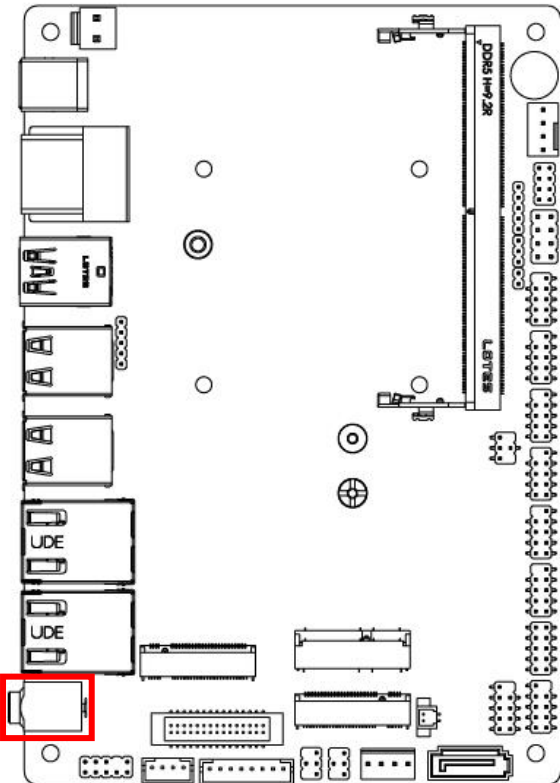

Note: Standard specifications.

(11) Internal 12V~28V Wide-Voltage Power Connector (DCIN)

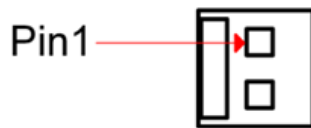
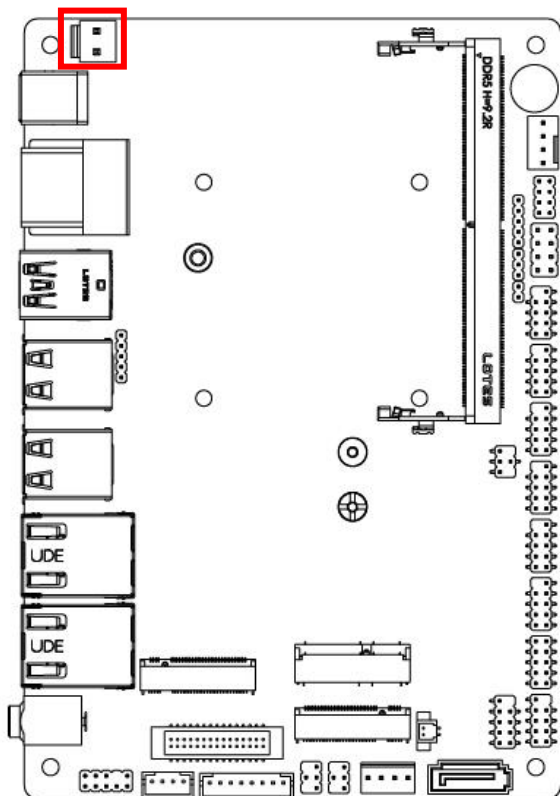

Pin No.	Definition
1	+12V~24VC DC-in
2	GND

(12) CPU FAN Connector (CPUFAN)

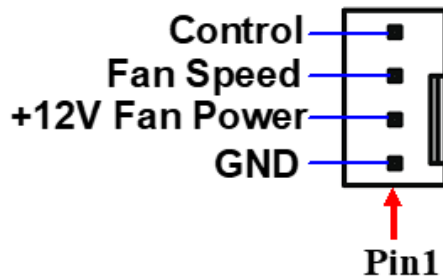
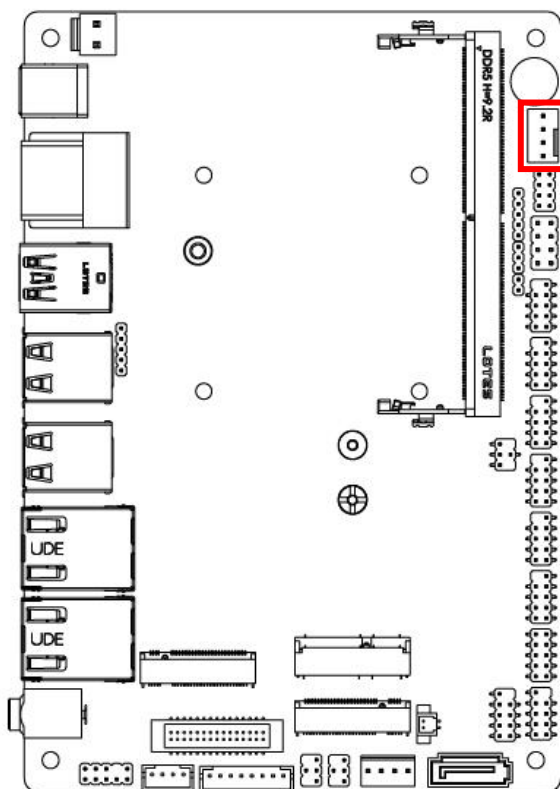

(13) SATA 3 Port Connector (SATA1)

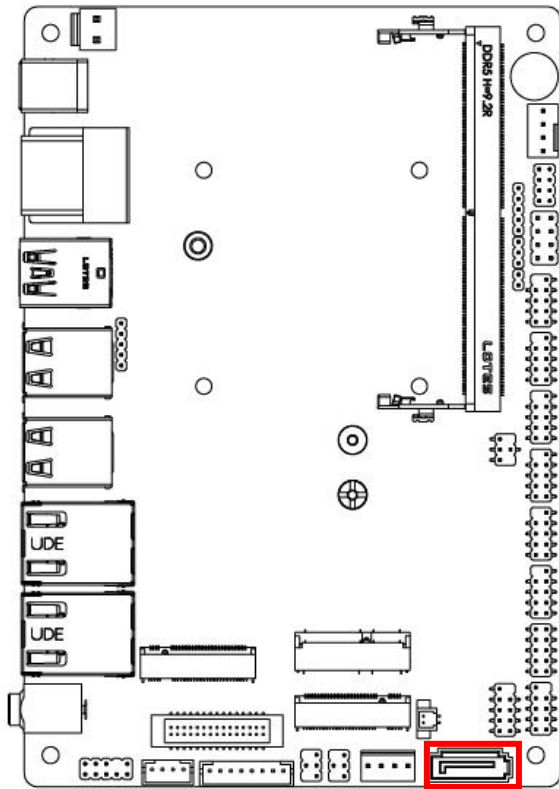

Pin No.	Definition
1	GND
2	TXP
3	TXN
4	GND
5	RXN
6	RXP
7	GND

Note: Standard specifications.

(14) SATA HDD Power-Out Connector (SATAPWR)

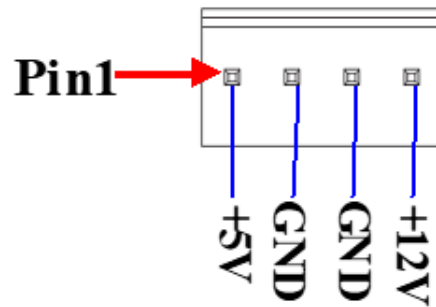
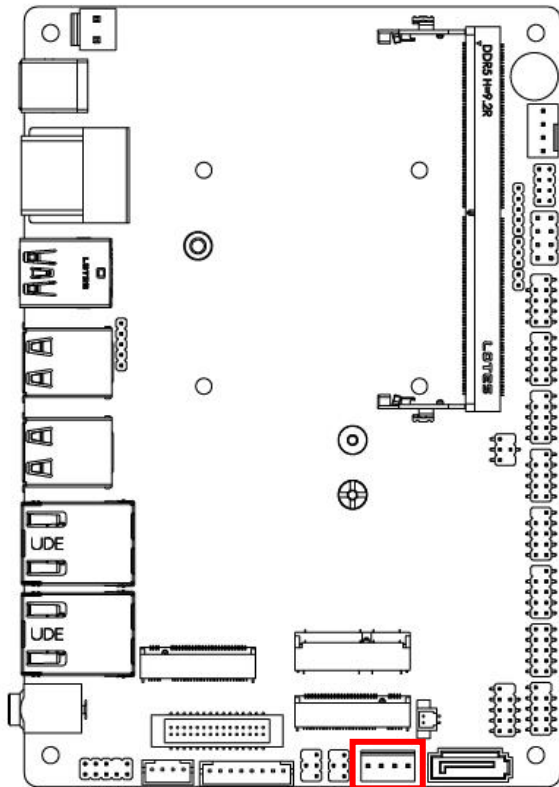

(15) RTC Battery Connector (BATCON-1)

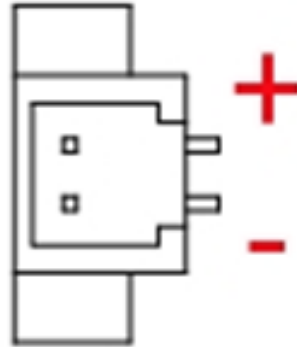
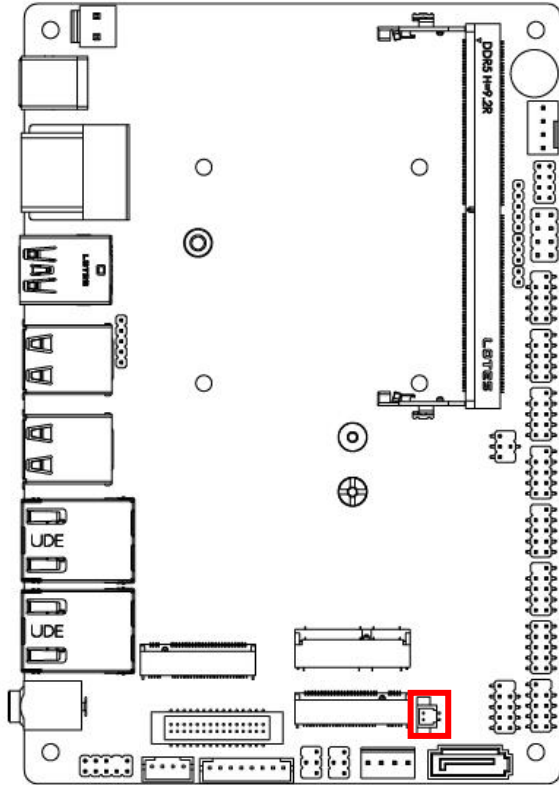

(16) Front Panel Header (JW_FP)

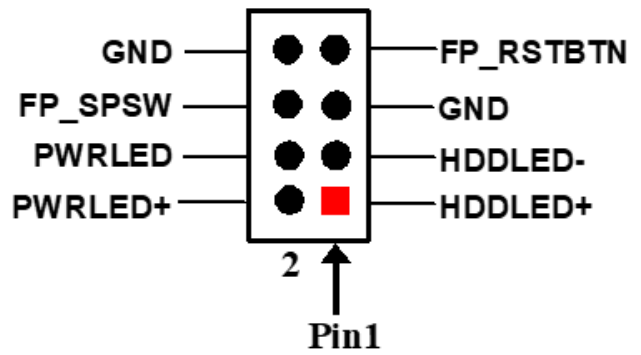
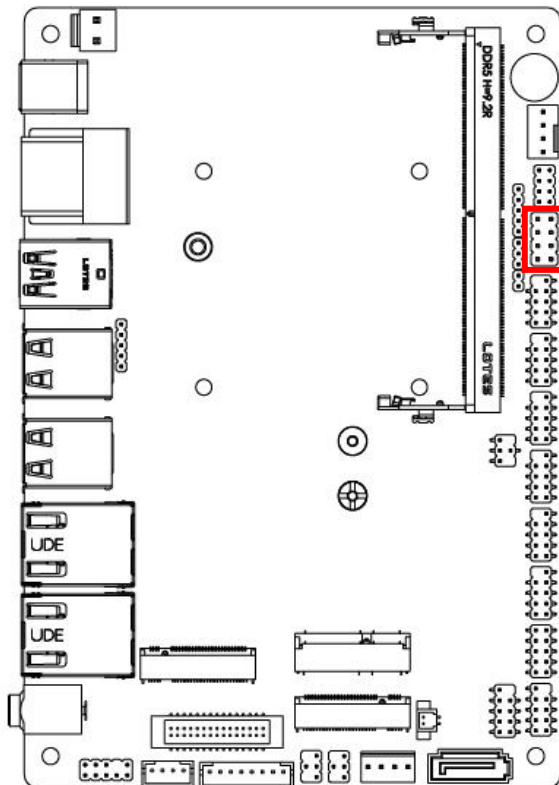

(17) USB2.0 Port Header (FP_USB21)

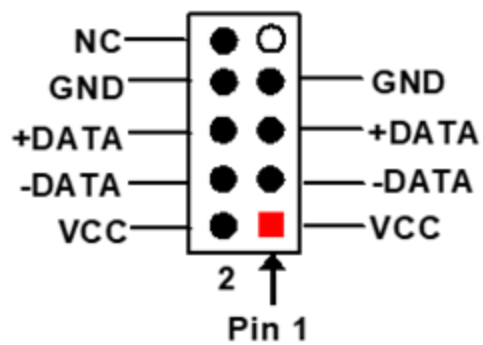
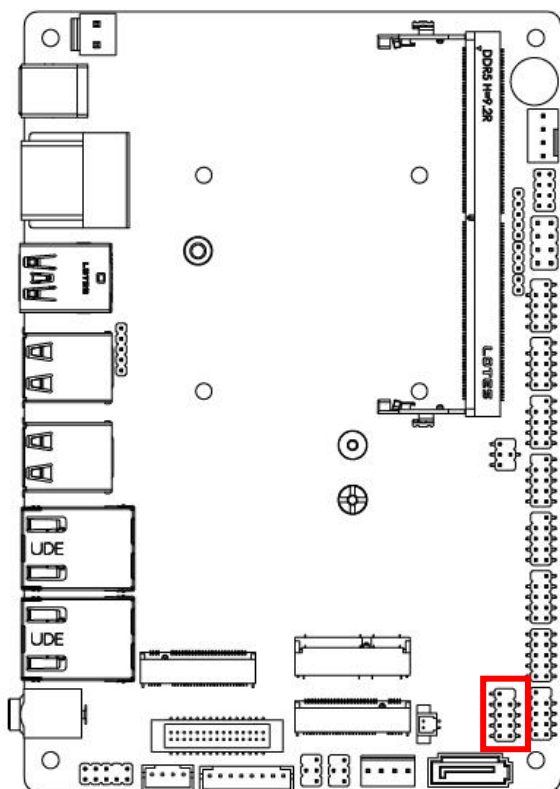

(18) USB2.0 Port Header (FP_USB22)

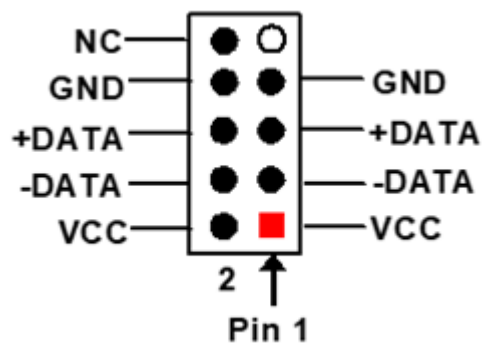
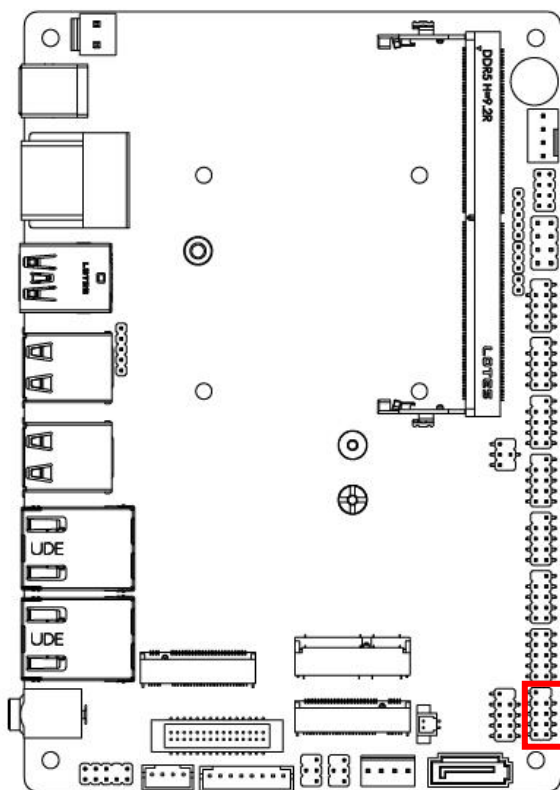

(19) Front Panel Line-Out, MIC-In Header (FP_AUDIO1)

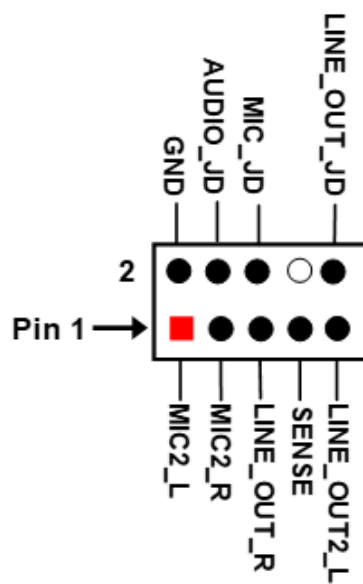
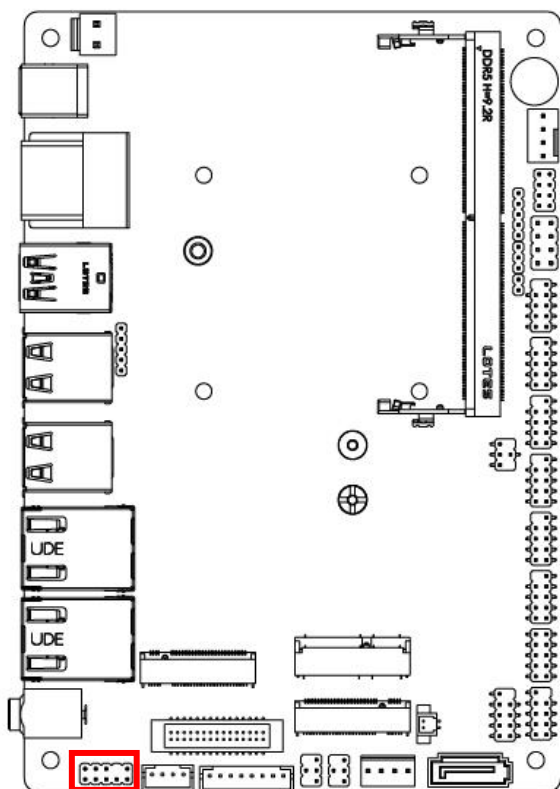

(20) 3W Amplifier Wafer (SPK_CON)

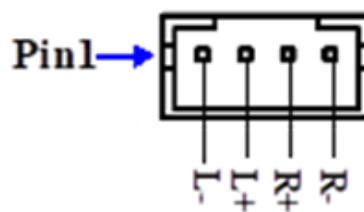
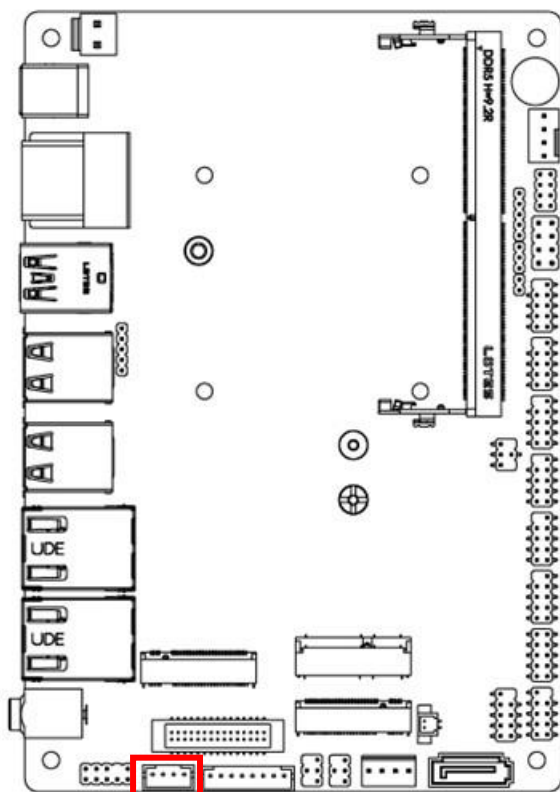

(21) 8 Bit GPIO Port /80 Port Header (GPIO)

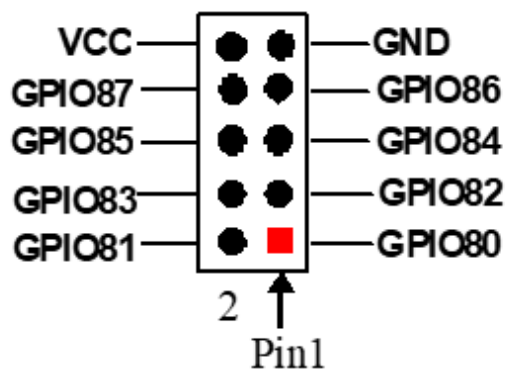
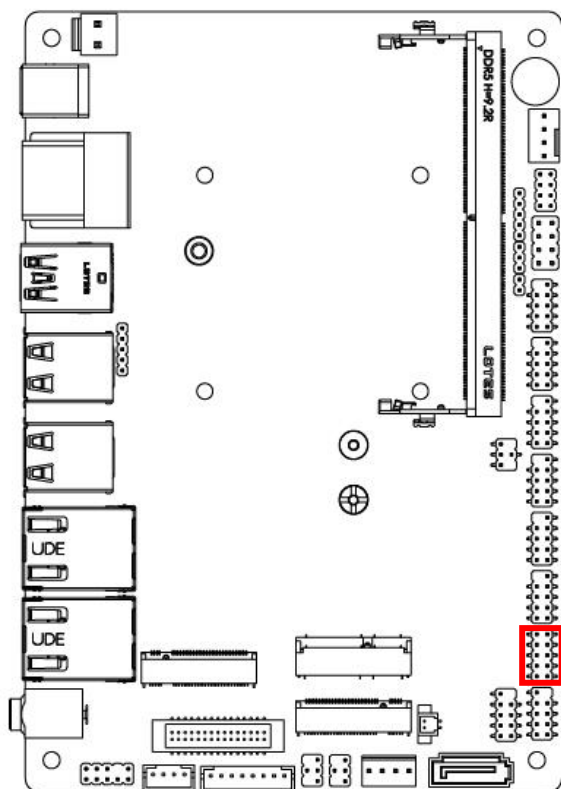

(22) SM BUS Header (SMBUS)

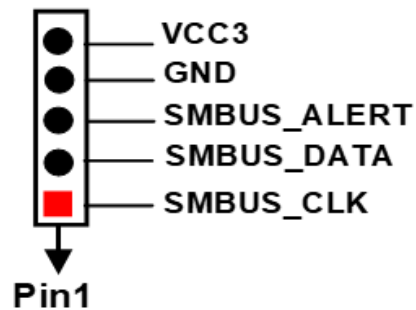
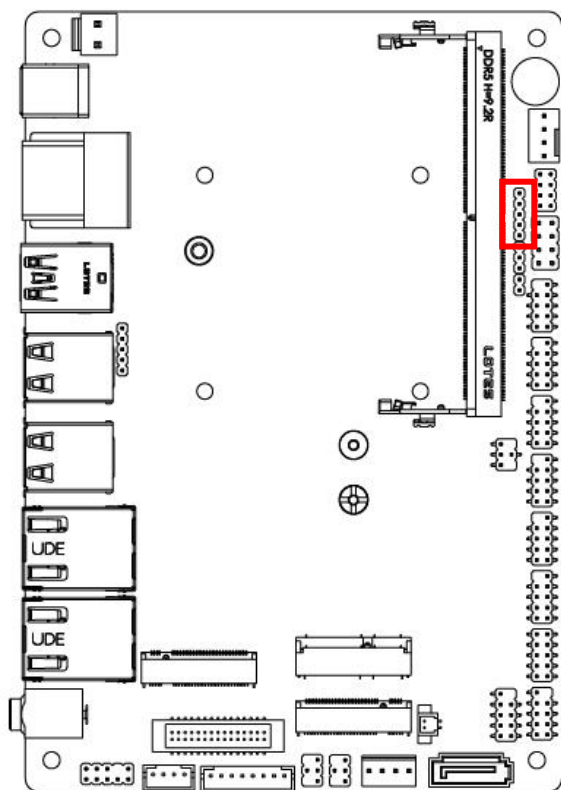

(23) RS232/RS422/RS485 Serial Port Header (FP_COM1)

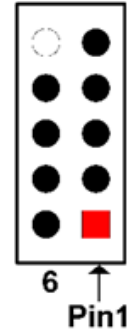
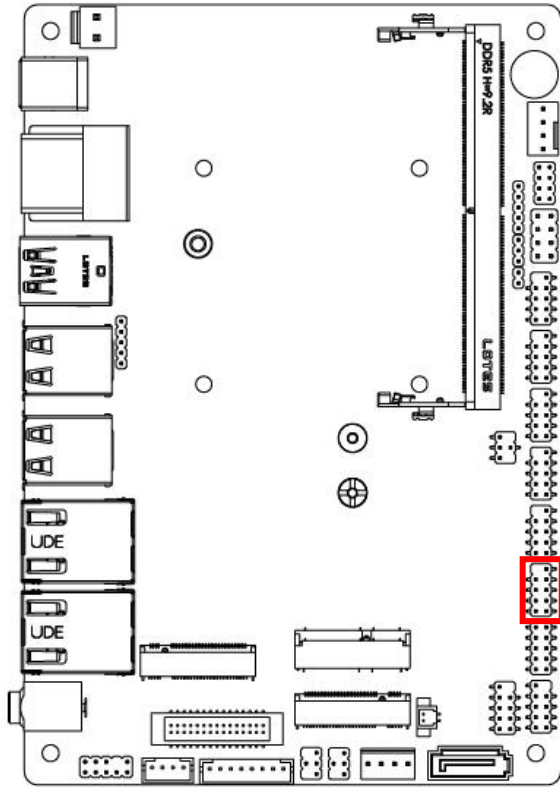

Pin NO.	RS232	*RS422	*RS485
Pin 1	DCD	TX-	DATA-
Pin 2	RXD	TX+	DATA+
Pin 3	TXD	RX+	NC
Pin 4	DTR	RX-	NC
Pin 5	GND	GND	GND
Pin 6	DSR	NC	NC
Pin 7	RTS	NC	NC
Pin 8	CTS	NC	NC
Pin 9	RI	NC	NC

(24) RS232 Serial Port Header (FP_COM2)

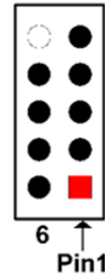
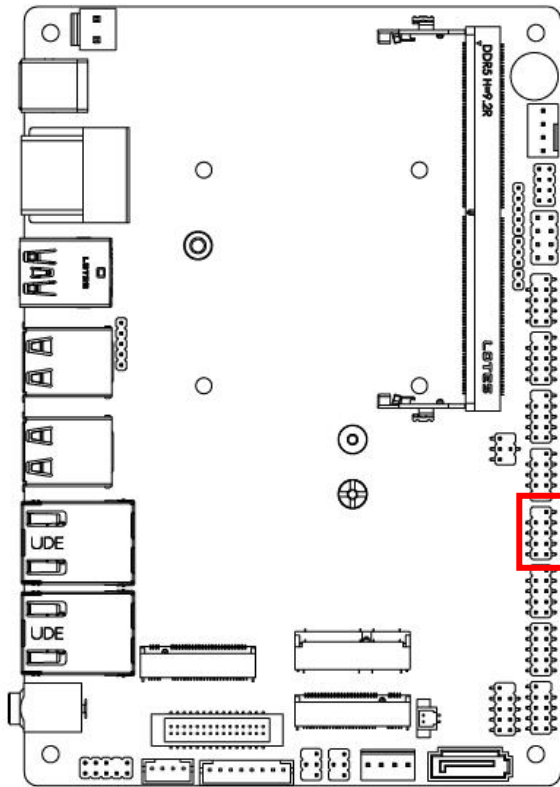

Pin NO.	RS232
Pin 1	DCD
Pin 2	RXD
Pin 3	TXD
Pin 4	DTR
Pin 5	GND
Pin 6	DSR
Pin 7	RTS
Pin 8	CTS
Pin 9	RI

(25) RS232 Serial Port Header (FP_COM3)

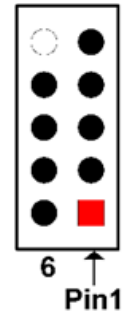
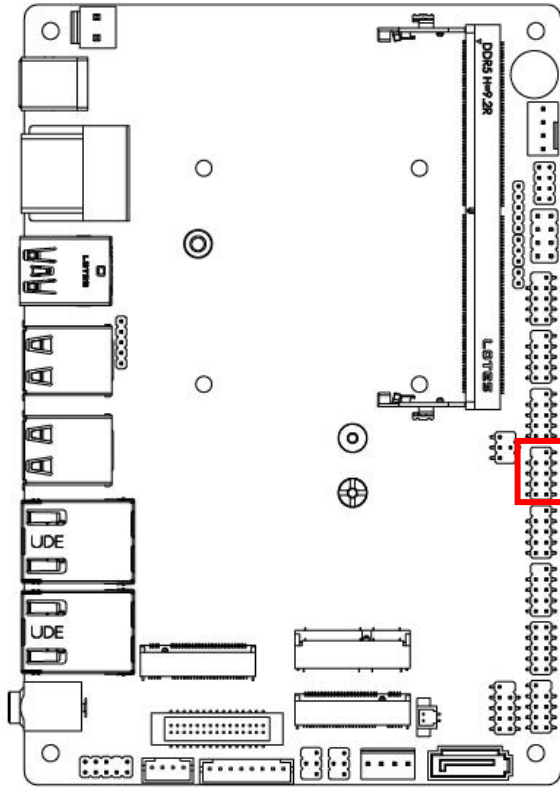

Pin NO.	RS232
Pin 1	DCD
Pin 2	RXD
Pin 3	TXD
Pin 4	DTR
Pin 5	GND
Pin 6	DSR
Pin 7	RTS
Pin 8	CTS
Pin 9	RI

(26) RS232 Serial Port Header (FP_COM4)

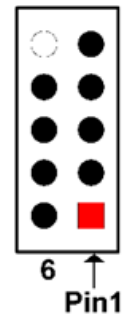
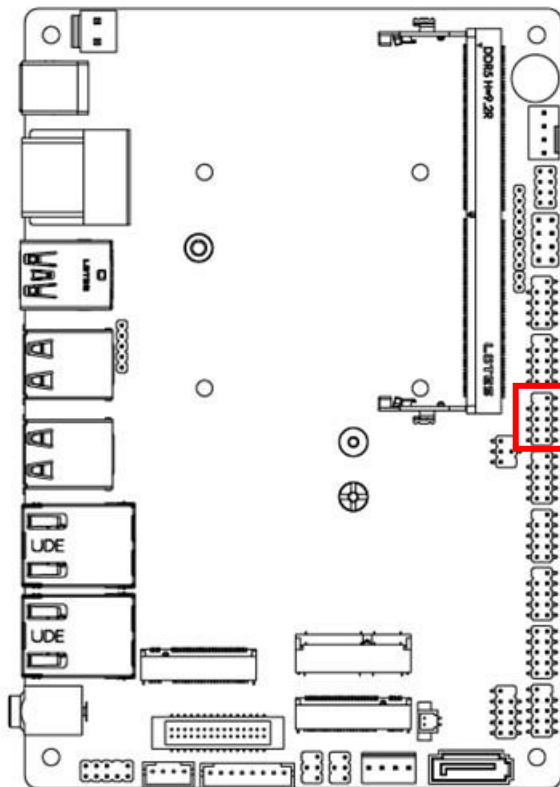

Pin NO.	RS232
Pin 1	DCD
Pin 2	RXD
Pin 3	TXD
Pin 4	DTR
Pin 5	GND
Pin 6	DSR
Pin 7	RTS
Pin 8	CTS
Pin 9	RI

(27) RS232 Serial Port Header (FP_COM5)

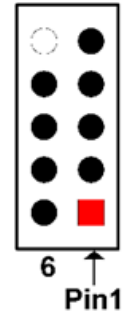
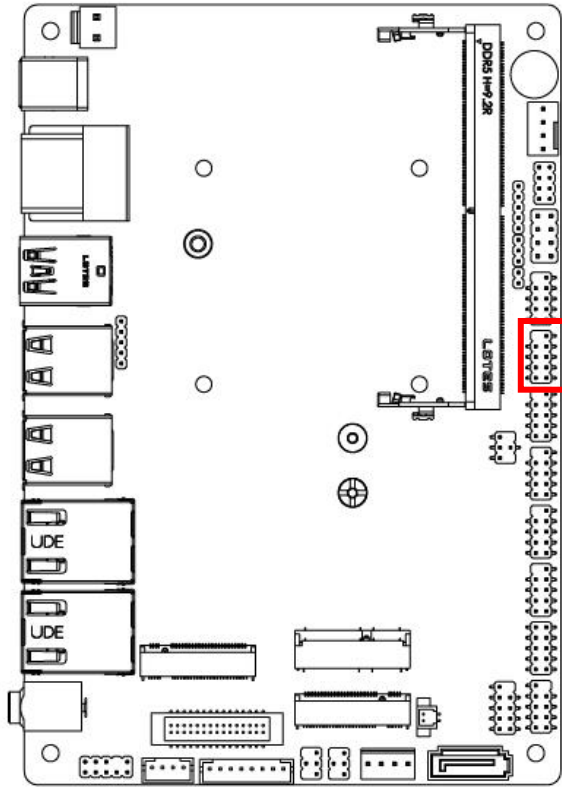

Pin NO.	RS232
Pin 1	DCD
Pin 2	RXD
Pin 3	TXD
Pin 4	DTR
Pin 5	GND
Pin 6	DSR
Pin 7	RTS
Pin 8	CTS
Pin 9	RI

(28) RS232 Serial Port Header (FP_COM6)

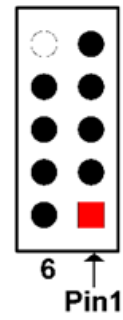
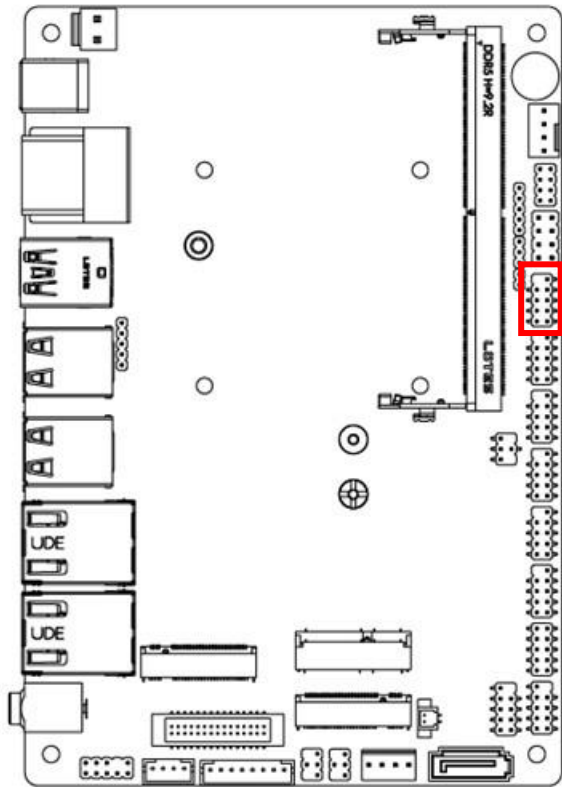

Pin NO.	RS232
Pin 1	DCD
Pin 2	RXD
Pin 3	TXD
Pin 4	DTR
Pin 5	GND
Pin 6	DSR
Pin 7	RTS
Pin 8	CTS
Pin 9	RI

(29) LVDS/EDP LCD Header (LVDS_EDP)

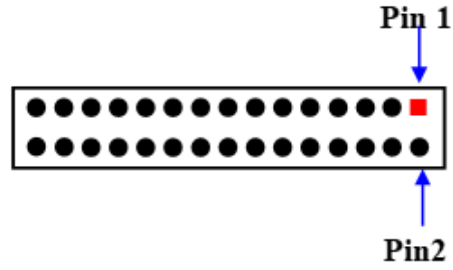
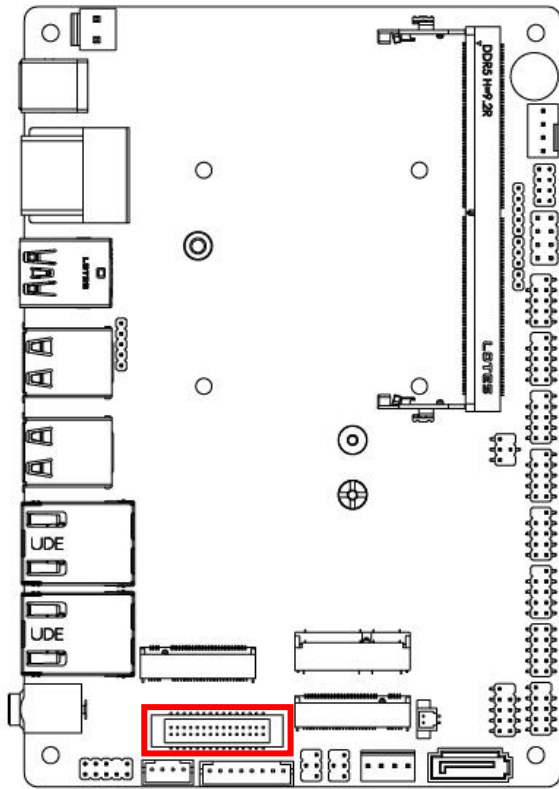

Pin Define	Pin NO.	Pin NO.	Pin Define
LVDSB_DATAN3	Pin 1	Pin 2	LVDSB_DATAP3
LVDSB_CLKN	Pin 3	Pin 4	LVDSB_CLKP
LVDSB_DATAN2	Pin 5	Pin 6	LVDSB_DATAP2
LVDSB_DATAN1	Pin 7	Pin 8	LVDSB_DATAP1
LVDSB_DATAN0	Pin 9	Pin 10	LVDSB_DATAP0
LVDS_DDC_SDA	Pin 11	Pin 12	LVDS_DDC_SCL
GND	Pin 13	Pin 14	GND
GND	Pin 15	Pin 16	GND
LVDSA_DATAP3	Pin 17	Pin 18	LVDSA_DATAN3
LVDSA_CLKP/eDP_AUXP	Pin 19	Pin 20	LVDSA_CLKN/eDP_AUXN
LVDSA_DATAP2/eDP_TX0P	Pin 21	Pin 22	LVDSA_DATAN2/eDP_TX0N
LVDSA_DATAP1/eDP_TX1P	Pin 23	Pin 24	LVDSA_DATAN1/eDP_TX1N
LVDSA_DATAP0	Pin 25	Pin 26	LVDSA_DATAN0
LCD_VCC	Pin 27	Pin 28	LCD_VCC
LCD_VCC	Pin 29	Pin 30	LCD_VCC

(30) LVDS/eDP Inverter Wafer (INVERTER)

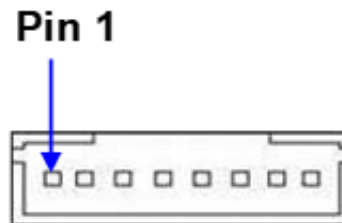
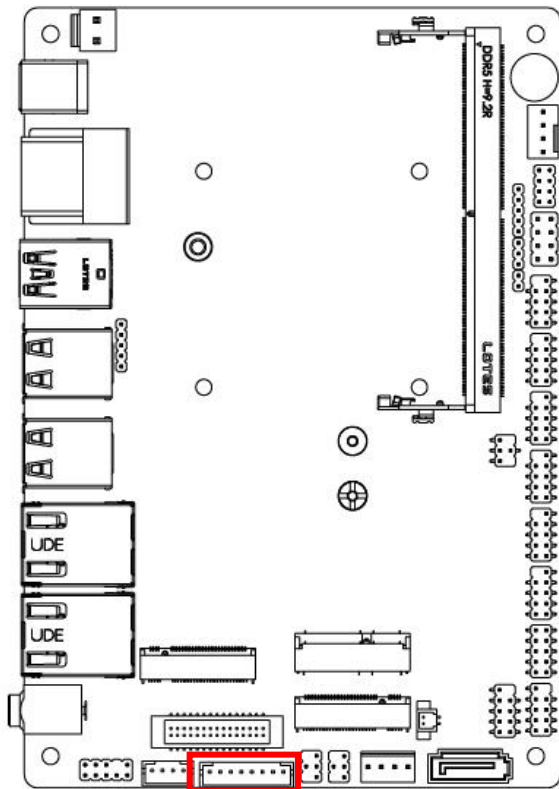

Pin No.	Definition
1	Backlight Enable
2	Backlight PWM
3	PVCC
4	PVCC
5	GND
6	GND
7	Backlight Up SW
8	Backlight Down SW

(31) Nano-SIM Card Socket (SIMCARDB)

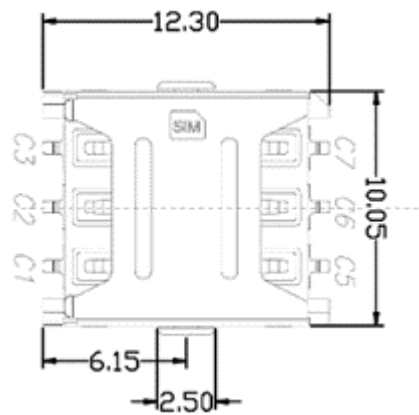
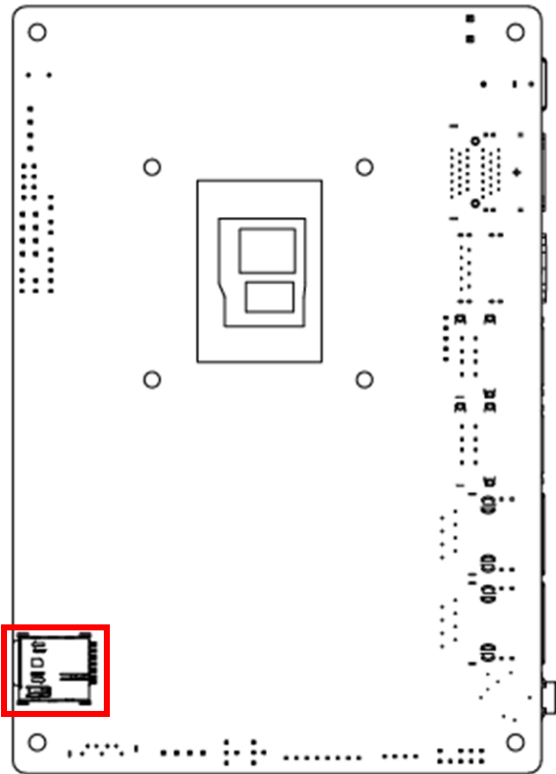

Note: Standard specifications.

(32) M.2 M KEY 2280 Socket (M2M1)

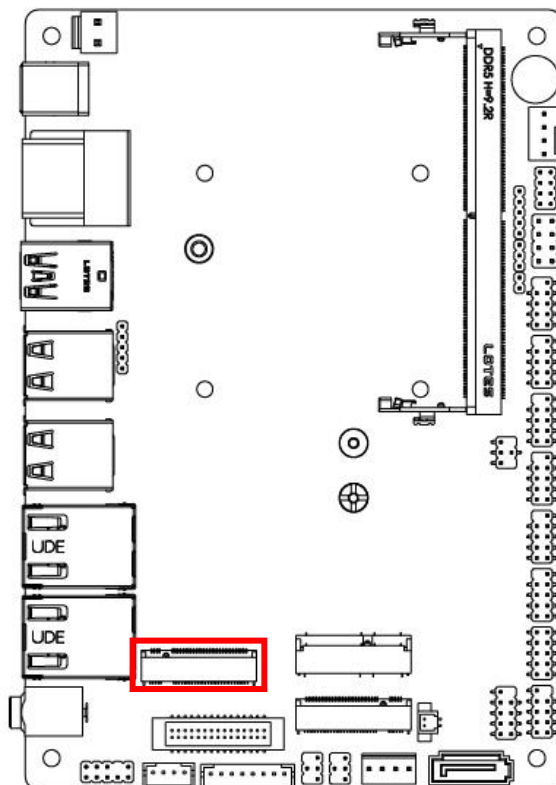

Note: Standard specifications.

(33) M.2 B KEY 3042/3052 Socket (M2B1)

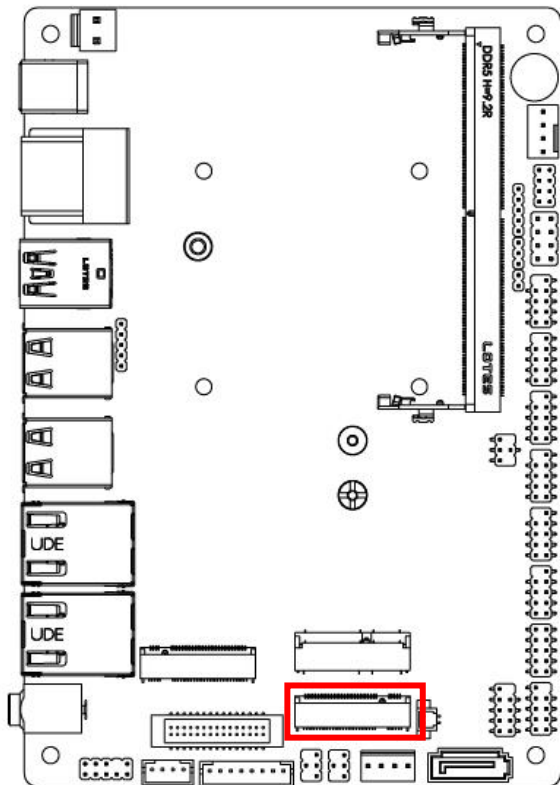

Note: Standard specifications.

(34) M.2 E KEY 2230 Socket (M2E1)

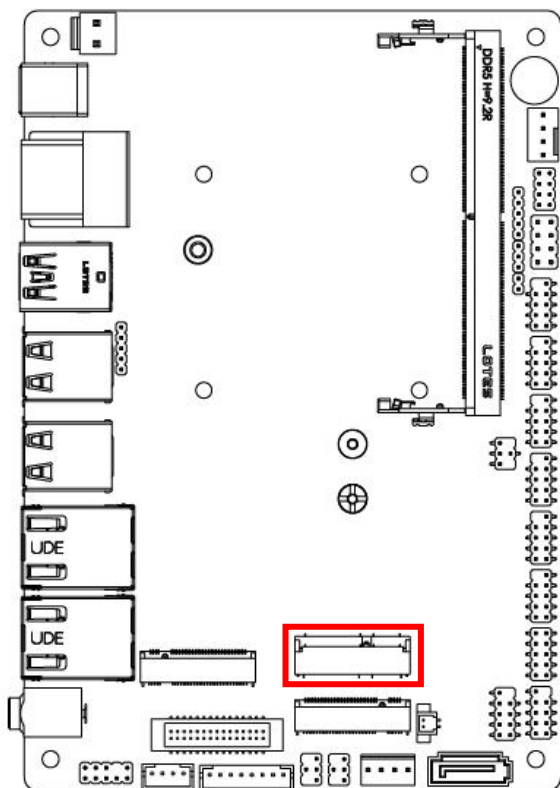

Note: Standard specifications.

(35) DDR5 SODIMM Socket (SODIMM1)

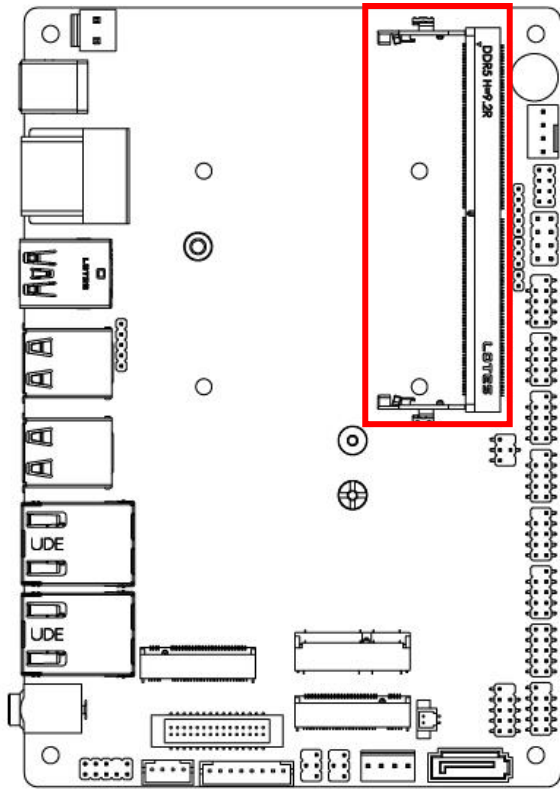

Note: Standard specifications.

2-5 Maximum Voltage & Current Limit

Below is a list of maximum voltage & Current Limit specification for motherboard interface (including but not limited to slots, connectors and headers) for setup reference:

Parts		Working Voltage	Current Support
USB Port from	USBC1 (Type-C ALT)	5V	3A
	USB31	5V	900mA
	USB21	5V	500mA x2
	USB22	5V	500mA x2
	FP_USB21	5V	500mA x2
	FP_USB22	5V	500mA x2
FP_COM1(JPCOM1)		5V/12V	500mA
JW_FP		5V	1A
GPIO		5V	1A
SMBUS		3.3V	500mA
LVDS_EDP (JPLCD)		3.3V/5V/12V (via jumper setting)	2A
INVERTER(JPBKL)		5V/12V/Adapter 12V (via jumper setting)	2A
CPUFAN		12V	1.5A
SATAPWR		5V	1A

Chapter 3 Introducing BIOS

Notice! The BIOS options in this manual are for reference only. Different configurations may lead to difference in BIOS screen and BIOS screens in manuals are usually the first BIOS version when the board is released and may be different from your purchased motherboard. Users are welcome to download the latest BIOS version from our official website.

The BIOS is a program located on a Flash Memory on the motherboard. This program is a bridge between motherboard and operating system. When you start the computer, the BIOS program will gain control. The BIOS first operates an auto-diagnostic test called POST (power on self test) for all the necessary hardware, it detects the entire hardware device and configures the parameters of the hardware synchronization. Only when these tasks are completed done it gives up control of the computer to operating system (OS). Since the BIOS is the only channel for hardware and software to communicate, it is the key factor for system stability, and in ensuring that your system performance as its best.

3-1 Entering Setup

Power on the computer and by pressing immediately allows you to enter Setup. If the message disappears before your respond and you still wish to enter Setup, restart the system to try again by turning it OFF then ON or pressing the “RESET” button on the system case. You may also restart by simultaneously pressing <Ctrl>, <Alt> and <Delete> keys. If you do not press the keys at the correct time and the system does not boot, an error message will be displayed and you will again be asked to

Press **** to enter Setup; press **< F7>** to enter pop-up Boot menu.

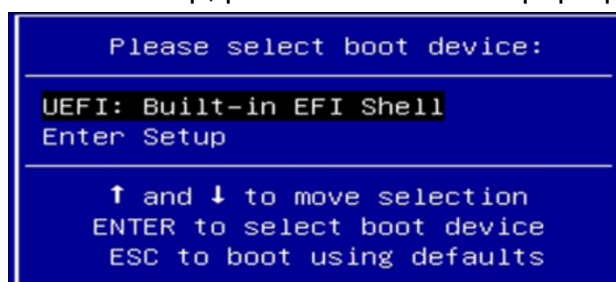

BIOS Boot Menu Screen (boot device options please refer to actual configuration)

3-2 BIOS Menu Screen

The following diagram show a general BIOS menu screen:

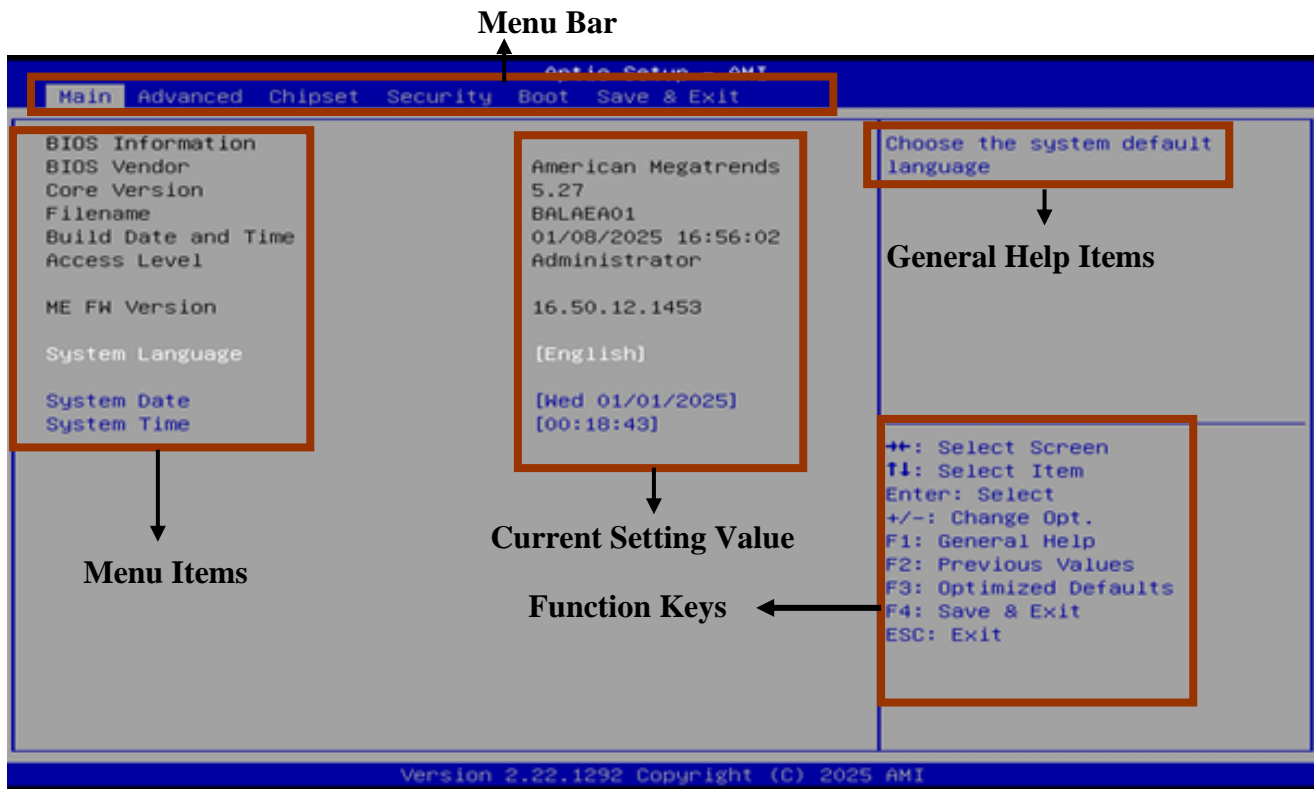

3-3 Function Keys

In the above BIOS Setup main menu of, you can see several options. We will explain these options step by step in the following pages of this chapter, but let us first see a short description of the function keys you may use here:

- Press ←→ (left, right) to select screen.
- Press ↑↓ (up, down) to choose, in the main menu, the option you want to confirm or to modify.
- Press <Enter> to select.
- Press <+>/<-> keys when you want to modify the BIOS parameters for the active option.
- [F1]: General help.
- [F2]: Previous values.
- [F3]: Optimized defaults.
- [F4]: Save & Exit.
- Press <Esc> to exit from BIOS Setup.

3-4 Getting Help

Main Menu

The on-line description of the highlighted setup function is displayed at the top right corner the screen.

Status Page Setup Menu/Option Page Setup Menu

Press **【F1】** to pop up a small help window that describes the appropriate keys to use and the possible selections for the highlighted item. To exit the Help Window, press **<Esc>**.

3-5 Menu Bars

There are six menu bars on top of BIOS screen:

Main	To change system basic configuration
Advanced	To change system advanced configuration
Chipset	To change chipset configuration
Security	Password settings
Boot	To change boot settings
Save & Exit	Save setting, loading and exit options.

User can press the right or left arrow key on the keyboard to switch from menu bar. The selected one is highlighted.

3-6 Main Menu

Main menu screen includes some basic system information. Highlight the item and then use the <+> or <-> and numerical keyboard keys to select the value you want in each item.

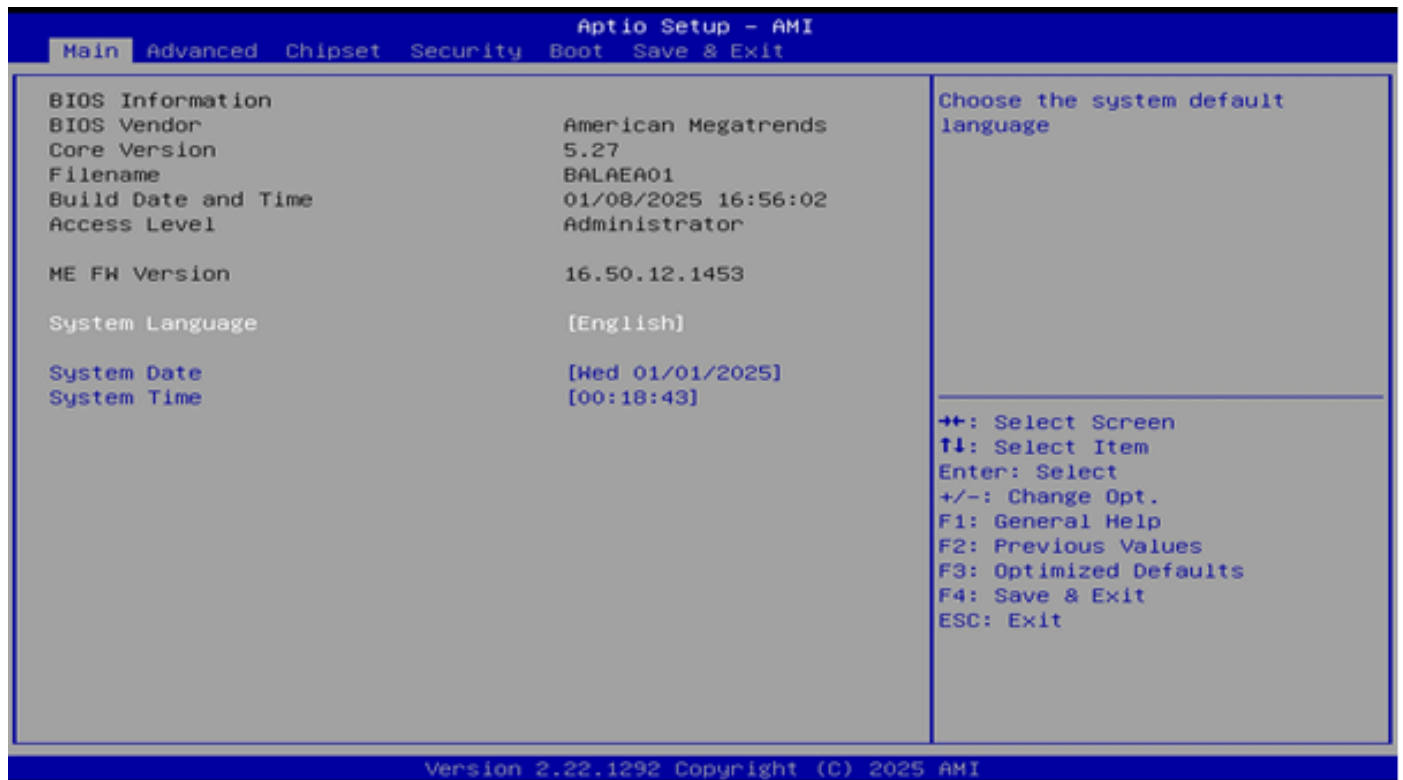

System Date

Set the date. Please use [Tab] to switch between date elements.

System Time

Set the time. Please use [Tab] to switch between time elements.

3-7 Advanced Menu



▶ **Connectivity Configuration**

Use this item to configure Connectivity related options. Press [Enter] to make settings for the following sub-items:

▶ **CPU Configuration**

Press [Enter] to view current CPU configuration and make settings for the following sub-items:

▶ **Efficient-Core Information**

Use this item to displays the E-Core information.

Press [Enter] to make settings for the following sub-items:

L1 Data Cache/L1 Instruction Cache/L2 Cache/L3 Cache

▶ **Performance-Core Information**

Boot Performance Mode

Use this item to select the performance state that the BIOS will set starting from reset vector.

Boot Performance Mode Set the default value to: [Turbo Performance]

The optional settings: [Min Non-Turbo Performance]; [Max Non-Turbo Performance]; [Turbo Performance].

Intel(R) SpeedStep(tm)

This item allows more than two frequency ranges to be supported.

Intel(R) SpeedStep(tm) Set the default value to: [Enabled]

The optional settings: [Disabled]; [Enabled].

Turbo Mode

Use this item to enable or disable processor Turbo Mode (requires Intel Speed Step or Intel Speed Shift to be available and enabled).

Turbo Mode Set the default value to: [Enabled]

The optional settings: [Disabled]; [Enabled]; [Customized]

C states

Use this item to enable or disable CPU Power Management. When set as [Enabled], it allows CPU to go to C states when it's not 100% utilized.

C states Set the default value to: [Enabled]

The optional settings: [Disabled]; [Enabled].

Enhanced C-states

Use this item to Enable/Disable C1E. When enabled, CPU will switch to minimum speed when all cores enter C-State.

Enhanced C-states Set the default value to: [Enabled]

The optional settings: [Disabled]; [Enabled].

Package C State Limit

Use this item to maximum package C State Limit setting. CPU default: leaves to factory default value. Auto: initializes to deepest available package C State Limit.

Package C State Limit Set the default value to: [Auto]

The optional settings: [C0/C1]; [C2]; [C3]; [C6]; [C7]; [C7S]; [C8]; [C9]; [C10]; [CPU Default]; [Auto].

▶ **Power & Performance**

Press [Enter] to make settings for the following sub-items:

▶ **CPU – Power Management Control**

CPU-Power Management Control Options.

Press [Enter] to make settings for the following sub-items:

Power Limit 1

Use this item to set Power Limit 1 in Milli Watts. BIOS will round to the nearest 1/8W when programming.

0 = no custom override. For 12.50W, enter 12500.

Overclocking SKU: Value must be between Max and Min Power Limits (specified by PACKAGE_POWER_SKU_MSR).

Other SKUs: This value must be between Min Power Limit and Processor Base Power (TDP) Limit. If value is 0, BIOS will program Processor Base Power (TDP) value.

Power Limit 1 Set the default value to: [0]

Power Limit 1 Time Window

Use this item to set Power Limit 1 Time Window value in seconds. The value may vary from 0 to 128. 0 = default value (28 sec for Mobile and 8 sec for Desktop). Defines time window which Processor Base Power (TDP) value should be maintained.

Power Limit 1 Time Window Set the default value to: [0]

The optional settings are: [0]; [1]; [2]; [3]; [4]; [5]; [6]; [7]; [8]; [10]; [12]; [14]; [16]; [20]; [24]; [28]; [32]; [40]; [48]; [56]; [64]; [80]; [96]; [112]; [128].

Power Limit 2

Use this item to set Power Limit 2 Value in Milli Watts. BIOS will round to the nearest 1/8W when programming.

0=no custom override. For 12.50w, enter 12500. Processor applies control policies such that the package power does not exceed this limit.

Power Limit 2 Set the default value to: [0]

▶ **GT-Power Management Control**

Press [Enter] to make settings for the following sub-items:

RC6(Render Standby)

Use this item to check to enable render standby support.

RC6(Render Standby) Set the default value to: [Enabled]

The optional settings: [Disabled]; [Enabled].

Maximum GT frequency

Use this item to Maximum GT frequency limited by the user. Choose between 200MHZ (RPN) and 1200MHZ (RP0). Value beyond the range will be clipped to min/max supported by SKU.

Maximum GT frequency Set the default value to: [Default Max Frequency]

The optional settings: [Default Max Frequency]; [100Mhz] ; [150Mhz] ; [200Mhz] ; [250Mhz] ; [300Mhz] ; [350Mhz] ; [400Mhz] ; [450Mhz] ; [500Mhz] ; [550Mhz] ; [600Mhz] ; [650Mhz] ; [700Mhz] ; [750Mhz] ; [800Mhz] ; [850Mhz] ; [900Mhz] ; [950Mhz] ; [1000Mhz] ; [1050Mhz] ; [1100Mhz] ; [1150Mhz] ; [1200Mhz].

Disable Turbo GT frequency

Use this item to enabled: disables turbo GT frequency. Disabled: GT frequency is not limited.

Disable Turbo GT frequency Set the default value to: [Disabled]

The optional settings: [Disabled]; [Enabled].

▶ **Trusted Computing**

Press [Enter] to make settings in the following sub-items:

Security Device Support

Use this item to Enables or Disables BIOS support for security device. O.S will not show security device. TCG EFI protocol and INT1A interface will not be available.

The optional settings: [Disabled]; [Enabled].

Security Device Support Set the default value to: [Enabled]

When set as [Enabled], user can make setting in the following items that appear:

SHA256 PCR Bank

Use this item to enable or disable SHA256 PCR Bank.

The optional settings: [Disabled]; [Enabled].

SHA256 PCR Bank Set the default value to: [Enabled]

SHA384 PCR Bank

Use this item to enable or disable SHA384 PCR Bank.

The optional settings: [Disabled]; [Enabled].

SHA384 PCR Bank Set the default value to: [Disabled]

SM3_256 PCR Bank

Use this item to enable or disable SM3_256 PCR Bank.

The optional settings: [Disabled]; [Enabled].

SM3_256 PCR Bank Set the default value to: [Disabled]

Pending Operation

Use this item to schedule an operation for security device.

The optional settings: [None]; [TPM Clear].

Pending Operation Set the default value to: [None]

****Note:** *Your computer will reboot during restart in order to change State of Security*

Device.

▶ **ACPI Settings**

Press [Enter] to make settings for the following sub-items:

PCH-FW ACPI Sleep State

Use this item to select the highest ACPI sleep state the system will enter when the SUSPEND button is pressed.

The optional settings are: [Suspend Disabled]; [S3 (Suspend to RAM)].

ACPI Sleep State Set the default value to: [S3 (Suspend to RAM)]

▶ **Super IO Configuration**

Press [Enter] to make settings for the following sub-items:

Super IO Configuration

Serial Port 1 Configuration

Press [Enter] to make settings for the following items:

Serial Port

Use this item to enable or disable serial port (COM).

The optional settings: [Disabled]; [Enabled].

Serial Port Set the default value to: [Enabled]

When set as [Enabled], user can make settings in the following items that appear:

Change Settings

Use this item to select an optimal settings for super IO device.

The optional settings are: [Auto]; [IO=3F8h; IRQ=4]; [IO=2F8h; IRQ=3]; [IO=3E8h; IRQ=4] ; [IO=2E8h; IRQ=3].

Change Settings Set the default value to: [Auto]

Transmission Mode Select

The optional settings are: [RS422]; [RS232]; [RS485].

Transmission Mode Select Set the default value to: [RS232]

Mode Speed Select

Use this item to RS232/RS422/RS485 Speed Select.

The optional settings are: [RS232/RS422/RS485=250Kbps]; [RS232=1Mbps, RS422/RS485=10Mbps].

Mode Speed Select Set the default value to: [RS232=1Mbps, RS422/RS485=10Mbps]

▶ **Serial Port 2 Configuration**

Press [Enter] to make settings for the following items:

Serial Port

Use this item to enable or disable serial port (COM).

The optional settings: [Disabled]; [Enabled].

Serial Port Select Set the default value to: [Enabled]

When set as [Enabled], user can make settings in the following items that appear:

Change Settings

Use this item to select an optimal setting for super IO device.

The optional settings are: [Auto]; [IO=3F8h; IRQ=4]; [IO=2F8h; IRQ=3]; [IO=3E8h; IRQ=4] ; [IO=2E8h; IRQ=3].

Change Settings Set the default value to: [Auto]

▶ **Serial Port 3 Configuration**

Press [Enter] to make settings for the following items:

Serial Port

Use this item to enable or disable serial port (COM).

The optional settings: [Disabled]; [Enabled].

Serial Port Select Set the default value to: [Enabled]

When set as [Enabled], user can make settings in the following items that appear:

▶ **Change Settings**

Use this item to select an optimal setting for super IO device.

The optional settings are: [Auto]; [IO=3F8h; IRQ=10]; [IO=2F8h; IRQ=10]; [IO=3E8h; IRQ=10] ; [IO=2E8h; IRQ=10] ; [IO=3F0h; IRQ=10] ; [IO=2E0h; IRQ=10].

Change Settings Set the default value to: [Auto]

▶ **Serial Port 4 Configuration**

Press [Enter] to make settings for the following items:

Serial Port

Use this item to enable or disable serial port (COM).

The optional settings: [Disabled]; [Enabled].

Serial Port Select Set the default value to: [Enabled]

When set as [Enabled], user can make settings in the following items that appear:

▶ **Change Settings**

Use this item to select an optimal setting for super IO device.

The optional settings are: [Auto]; [IO=3F8h; IRQ=10]; [IO=2F8h; IRQ=10]; [IO=3E8h; IRQ=10] ; [IO=2E8h; IRQ=10] ; [IO=3F0h; IRQ=10] ; [IO=2E0h; IRQ=10].

Change Settings Set the default value to: [Auto]

▶ **Serial Port 5 Configuration**

Press [Enter] to make settings for the following items:

Serial Port

Use this item to enable or disable serial port (COM).

The optional settings: [Disabled]; [Enabled].

Serial Port Select Set the default value to: [Enabled]

When set as [Enabled], user can make settings in the following items that appear:

▶ **Change Settings**

Use this item to select an optimal setting for super IO device.

The optional settings are: [Auto]; [IO=3F8h; IRQ=11]; [IO=2F8h; IRQ=11]; [IO=3E8h; IRQ=11]; [IO=2E8h; IRQ=11]; [IO=2F0h; IRQ=11]; [IO=2E0h; IRQ=11].

Change Settings Set the default value to: [Auto]

► **Serial Port Configuration**

Press [Enter] to make settings for the following items:

Serial Port

Use this item to enable or disable serial port (COM).

The optional settings: [Disabled]; [Enabled].

Serial Port Select Set the default value to: [Enabled]

When set as [Enabled], user can make settings in the following items that appear:

► **Change Settings**

Use this item to select an optimal setting for super IO device.

The optional settings are: [Auto]; [IO=3F8h; IRQ=11]; [IO=2F8h; IRQ=11]; [IO=3E8h; IRQ=11]; [IO=2E8h; IRQ=11]; [IO=2F0h; IRQ=11]; [IO=2E0h; IRQ=11].

Change Settings Set the default value to: [Auto]

ERP Support

Use this item to make setting for energy-related products function. Disable ERP to active all wake-up function.

The optional settings: [Disabled]; [Enabled].

ERP Support Set the default value to: [Disabled]

Case Open Detect

Use this item to detect if case have ever been opened. Show message in POST.

The optional settings: [Disabled]; [Enabled].

Case Open Detect Set the default value to: [Disabled]

When set as [Enabled], system will detect if COPEN has been short or not (*refer to **JCLAR** jumper setting for Case Open Detection*); if Pin 7&8 of **JCLAR** are short, system will show Case Open Message during POST.

WatchDog Reset Timer

Use this item to support WDT reset function.

The optional settings: [Disabled]; [Enabled].

WatchDog Reset Timer Set the default value to: [Disabled]

When set as [Enabled], user can make settings in the following items that appear:

WatchDog Reset Timer Value

User can set a value in the range of [10] to [255] seconds or [1] to [255] minutes.

WatchDog Reset Timer Value Set the default value to: [10]

WatchDog Reset Timer Unit

The optional settings are: [Sec.]; [Min.].

WatchDog Reset Timer Unit Set the default value to: [Sec]

ATX Power Emulate AT Power

This item support Emulate AT power function, MB power On/Off control by power supply. Use needs to select 'AT or ATX Mode' on MB jumper at first (refer to **ATX_Mode** jumper setting Pin 1&2 of for **ATX Mode** & Pin 2&3 of **AT Mode** Select).

▶ **Serial Port Console Redirection**

Press [Enter] to make settings for the following sub-items:

COM1

Console Redirection

Console Redirection enable or disable.

The optional settings: [Disabled]; [Enabled].

Console Redirection Set the default value to: [Disabled]

When set as **[Enabled]**, user can make further settings in the '**Console Redirection Settings**' screen:

▶ **Console Redirection Settings**

The settings specify how the host computer and the remote computer (which the user is using) will exchange data. Both computers should have the same or compatible settings.

Press [Enter] to make settings for the following sub-items:

Terminal Type

The optional settings: [VT100]; [VT100Plus]; [VT-UTF8]; [ANSI].

[ANSI]: Extended ASCII char set;

[VT100]: ASCII char set;

[VT100Plus]: Extends VT100 to support color, function keys, etc.

[VT-UTF8]: Uses UTF8 encoding to map Unicode chars onto 1 or more bytes.

Terminal Type Set the default value to: [ANSI]

Bits per second

Use this item to select serial port transmission speed. The speed must be matched on the other side. Long or noisy lines may require lower speeds.

The optional settings: [9600]; [19200]; [38400]; [57600]; [115200].

Bits per second Set the default value to: [115200]

Data Bits

The optional settings: [7]; [8].

Data Bits Set the default value to: [8]

Parity

A parity bit can be sent with the data bits to detect some transmission errors.

The optional settings: [None]; [Even]; [Odd]; [Mark]; [Space].

[Even]: parity bit is 0 if the num of 1's in the data bits is even;

[Odd]: parity bit is 0 if num of 1's in the data bits is odd;

[Mark]: parity bit is always 1;

[Space]: parity bit is always 0;

Parity Set the default value to: [None]

[Mark] and **[Space]**: parity do not allow for error detection. They can be used as an additional

data bit.

Stop Bits

Stop bits indicate the end of a serial data packet. (A start bit indicates the beginning). The standard setting is 1 stop bit. Communication with slow devices may require more than 1 stop bit.

The optional settings: [1]; [2].

Stop Bits Set the default value to: [1]

Flow Control

Flow control can prevent data loss from buffer overflow. When sending data, if the receiving buffers are full, a “stop” signal can be sent to stop the data flow. Once the buffers are empty, a “start” signal can be sent to re-start the flow. Hardware flow control uses two wires to send start/stop signals.

The optional settings: [None]; [Hardware RTS/CTS].

Flow Control Set the default value to: [None]

VT-UTF8 Combo Key Support

Use this item to enable VT-UTF8 Combination Key Support for ANSI/VT100 terminals.

The optional settings: [Disabled]; [Enabled].

VT-UTF8 Combo Key Support Set the default value to: [Enabled]

Recorder Mode

With this mode enabled only text will be sent. This is to capture Terminal data.

The optional settings: [Disabled]; [Enabled].

Recorder Mode Set the default value to: [Disabled]

Resolution 100x31

Use this item to enable or disable extended terminal resolution.

The optional settings: [Disabled]; [Enabled].

Resolution 100x31 Set the default value to: [Disabled]

Putty KeyPad

Use this item to select FunctionKey and KeyPad on Putty.

The optional settings: [VT100]; [LINUX]; [XTERMR6]; [SCO]; [ESCN]; [VT400].

Putty KeyPad Set the default value to: [VT100]

Serial Port for Out-of-Band Management/

Windows Emergency Management Services (EMS)

Console Redirection EMS

Use this item to enable or disable console redirection.

The optional settings: [Disabled]; [Enabled].

Console Redirection EMS Set the default value to: [Disabled]

When set as **[Enabled]**, user can make further settings in ‘**Console Redirection Settings**’ screen:

► **Console Redirection Settings**

The settings specify how the host computer and the remote computer (which the user is using) will exchange data. Both computers should have the same or compatible settings.

Press [Enter] to make settings for the following sub-items.

Terminal Type EMS

The optional settings: [VT100]; [VT100Plus]; [VT-UTF8]; [ANSI].

[VT-UTF8] is the preferred terminal type for out-of-band management. The next best choice is

[VT100+] and then [VT100]. See above, in Console Redirection Settings page, for more help with Terminal Type/Emulation.

Terminal Type EMS Set the default value to: [VT-UTF8]

Bits per second EMS

Use this item to select serial port transmission speed. The speed must be matched on the other side. Long or noisy lines may require lower speeds.

The optional settings: [9600]; [19200]; [57600]; [115200].

Bits per second EMS Set the default value to: [115200]

Flow Control EMS

Flow control can prevent data loss from buffer overflow. When sending data, if the receiving buffers are full, a “stop” signal can be sent to stop the data flow. Once the buffers are empty, a “start” signal can be sent to re-start the flow. Hardware flow control uses two wires to send start/stop signals.

The optional settings: [None]; [Hardware RTS/CTS]; [Software Xon/Xoff].

Flow Control EMS Set the default value to: [None]

Data Bits EMS

The default setting is: [8].

**This item may or may not show up, depending on different configuration.*

Parity EMS

The default setting is: [None].

**This item may or may not show up, depending on different configuration.*

Stop Bits EMS

The default setting is: [1].

**This item may or may not show up, depending on different configuration.*

▶ **PC Health Status**

Press [Enter] to view current hardware health status, make further settings in ‘**SmartFAN Configuration**’.

▶ **SmartFAN Configuration**

Press [Enter] to make settings for SmartFAN Configuration:

SmartFAN Configuration

CPUFAN Smart Mode

The optional settings: [Disabled]; [Enabled].

CPUFAN Smart Mode Set the default value to: [Enabled]

When set as [Enabled], the following sub-items shall appear:

CPUFAN Full-Speed Temperature

Use this item to set CPUFAN full speed temperature. Fan will run at full speed when above this pre-set temperature.

CPUFAN Full-Speed Temperature Set the default value to: [75]

CPUFAN Full-Speed Duty

Use this item to set CPUFAN full-speed duty. Fan will run at full speed when above this pre-set duty.

CPUFAN Full-Speed Duty Set the default value to: [100]

CPUFAN Idle-Speed Temperature

Use this item to set CPUFAN idle speed temperature. Fan will run at idle speed when below this pre-set temperature.

CPUFAN Idle-Speed Temperature Set the default value to: [40]

CPUFAN Idle-Speed Duty

Use this item to set CPUFAN idle speed duty. Fan will run at idle speed when below this pre-set duty.

CPUFAN Idle-Speed Duty Set the default value to: [40]

► **USB Configuration**

Press [Enter] to make settings for the following sub-items:

USB Configuration

XHCI Hand-off

This is a workaround for OSeS without XHCI hand-off support. The XHCI ownership change should be claimed by XHCI driver.

The optional settings: [Enabled]; [Disabled].

XHCI Hand-off Set the default value to: [Disabled].

USB Mass Storage Driver Support

Use this item to enable or disable USB Mass storage driver support.

The optional settings: [Disabled]; [Enabled].

USB Mass Storage Driver Support Set the default value to: [Enabled].

USB hardware delay and time-out

USB Transfer time-out

Use this item to set the time-out value for control, bulk, and interrupt transfers.

The optional settings: [1 sec]; [5 sec]; [10 sec]; [20 sec].

USB Transfer time-out Set the default value to: [20 sec]

Device reset time-out

Use this item to set USB mass storage device start unit command time-out.

The optional settings: [10 sec]; [20 sec]; [30 sec]; [40 sec].

Device reset time-out Set the default value to: [20 sec]

Device power-up delay

Use this item to set maximum time the device will take before it properly reports itself to the host controller. 'Auto' uses default value: for a root port it is 100 ms, for a hub port the delay is taken from hub descriptor.

The optional settings: [Auto]; [Manual].

Device power-up delay Set the default value to: [Auto]

Select **[Manual]** you can set value for the following sub-item: 'Device power-up delay in seconds', the delay range is 1 .. 40 seconds, in one second increments.

▶ **Network Stack Configuration**

Press [Enter] to go to 'Network Stack' screen to make further settings.

Network Stack

Use this item to enable or disable UEFI Network Stack.

The optional settings: [Disabled]; [Enabled].

Network Stack Set the default value to: [Disabled]

When set as **[Enabled]**, the following sub-items shall appear:

IPv4 PXE Support

Use this item to enable/disable IPv4 PXE Boot Support. When set as [Disabled], IPv4 PXE boot support will not be available.

The optional settings: [Disabled]; [Enabled].

IPv4 PXE Support Set the default value to: [Enabled]

IPv6 PXE Support

Use this item to enable/disable IPv6 PXE Boot Support. When set as [Disabled], IPv6 PXE boot support will not be available.

The optional settings: [Disabled]; [Enabled].

IPv6 PXE Support Set the default value to: [Disabled]

PXE boot wait time

Wait time in seconds to press [ESC] key to abort the PXE boot.

Use either [+]/[-] or numeric keys to set the value.

PXE boot wait time Set the default value to: [5]

Media detect count

Use this item to set number of times presence of media will be checked.

Use either [+]/[-] or numeric keys to set the value.

Media detect count Set the default value to: [5]

▶ **NVMe Configuration**

Use this item to set NVMe Device options settings.

NVMe Configuration

▶ **Wake-up Function Settings**

Wake-up System With Fixed Time

**This item will only show when 'Wake-up System with Dynamic Time' is set as [Disabled].*

Use this item to enable or disable system wake-up by RTC alarm. When this function is enabled, system will wake on the time (hr::min::sec) specified.

The optional settings: [Disabled]; [Enabled].

Wake-up System With Fixed Time Set the default value to: [Disabled]

When set as [Enabled], user can make settings in the following items that appear:

Wake-up Hour

Use this item to select 0-23 for example enter 3 for 3am and 15 for 3pm.

Wake-up Hour Set the default value to: [0]

Wake-up Minute

Use this item to select 0-59.

Wake-up Minute Set the default value to: [0]

Wake-up Second

Use this item to select 0-59.

Wake-up Second Set the default value to: [0]

Wake-up System with Dynamic Time

**This item will only show when 'Wake-up System with Fixed Time' is set as [Disabled].*

Use this item to enable or disable system wake-up by RTC alarm. When enabled, system will wake on the current time + Increase minute(s).

Wake-up System with Dynamic Time Set the default value to: [Disabled]

When set as [Enabled], user can make settings in the following items that appear:

Wake-up Minute Increase

Use this item to select 1-60 minute(s).

Wake-up Minute Increase Set the default value to: [1]

USB Power Gating S4-S5

The optional settings: [Disabled]; [Enabled].

USB S5 Power Set the default value to: [Enabled].

PCIe Wake-up from S4-S5

The optional settings: [Disabled]; [Enabled].

PCIe Wake-up from S4-S5 Set the default value to: [Disabled]

▶ **PTT Configuration**

Press [Enter] to make settings for the following sub-items:

TPM Device Selection

The optional settings: [dTPM];[PTT]

TPM Device Selection Set the default value to: [PTT]

3-8 Chipset Menu



▶ System Agent (SA) Configuration

Press [Enter] to make settings for the following sub-items:

System Agent (SA) Configuration

GTT Size

Use this item to select GTT Size.

The optional settings are: [2MB]; [4MB]; [8MB].

GTT Size Set the default value to: [8MB]

DVMT Pre-Allocated

Select DVMT 5.0 Pre-Allocated (Fixed) Graphics Memory size used by the Internal Graphics Device.

The optional settings: [32M]; [64M]; [96M]; [128M]; [160M].

DVMT Pre-Allocated Set the default value to: [128M]

Active LVDS/eDP

Use this item to select the Active LVDS/eDP Configuration.

The optional settings: [Disabled]; [Enabled].

Active LFP Set the default value to: [Disabled]

When set as [Enabled], the following sub-item shall appear:

Panel Type

The optional settings are: [800x480 1ch 18-bit]; [800x600 1ch 18-bit]; [800x600 1ch 24-bit]; [1024x600 1ch 18-bit]; [1024x768 1ch 18-bit]; [1024x768 1ch 24-bit]; [1280x800 1ch 18-bit]; [1280x800 1ch 24-bit]; [1366x768 1ch 18-bit]; [1366x768 1ch 24-bit]; [1440x900 2ch 18-bit];

[1440x900 2ch 24-bit]; [1280x1024 2ch 24-bit]; [1680x1050 2ch 24-bit]; [1920x1080 2ch 24-bit]; [eDP].

Panel Type Set the default value to: [eDP]

Backlight Control

Use this item to make back light control setting.

The optional settings are: [PWM Inverted]; [PWM Normal].

Backlight Control Set the default value to: [PWM Normal]

Maximum Memory Frequency

Maximum Memory Frequency Selections in Mhz.

The optional settings: [Auto]; [4000] ; [4400] ; [4800] ; [5200] ; [5600].

▶ **PCH-IO Configuration**

Press [Enter] to make settings for the following sub-items:

PCH-IO Configuration

▶ **SATA Configuration**

SATA Device Options Settings.

SATA Configuration

SATA Controller(s)

Use this item to enable/disable SATA Device.

The optional settings are: [Enabled]; [Disabled].

SATA Controller(s) Set the default value to: [Enabled]

When set as [Enabled], the following sub-items shall appear:

SATA Mode Selection

Use this item to determines how SATA controller(s) operate.

The optional settings are: [AHCI].

SATA Mode Selection Set the default value to: [AHCI]

SATA Port

Port

Use this item to enable or disable SATA Port.

The optional settings are: [Disabled]; [Enabled].

Port Set the default value to: [Enabled]

HD Audio

Use this item to control detection of the HD-Audio device.

Disabled= HDA will be unconditionally disabled.

Enabled= HDA will be unconditionally enabled.

The optional settings: [Disabled]; [Enabled].

HD Audio Set the default value to: [Enabled]

eMMC Controller

The optional settings: [Disabled]; [Enabled].

eMMC Controller Set the default value to: [Enabled]

System State after Power Failure

Specify what state to go to when power is re-applied after a power failure (G3 state).

The optional settings: [Always On]; [Always Off]; [Former State].

System State after Power Failure Set the default value to: [Always Off]

3-9 Security Menu

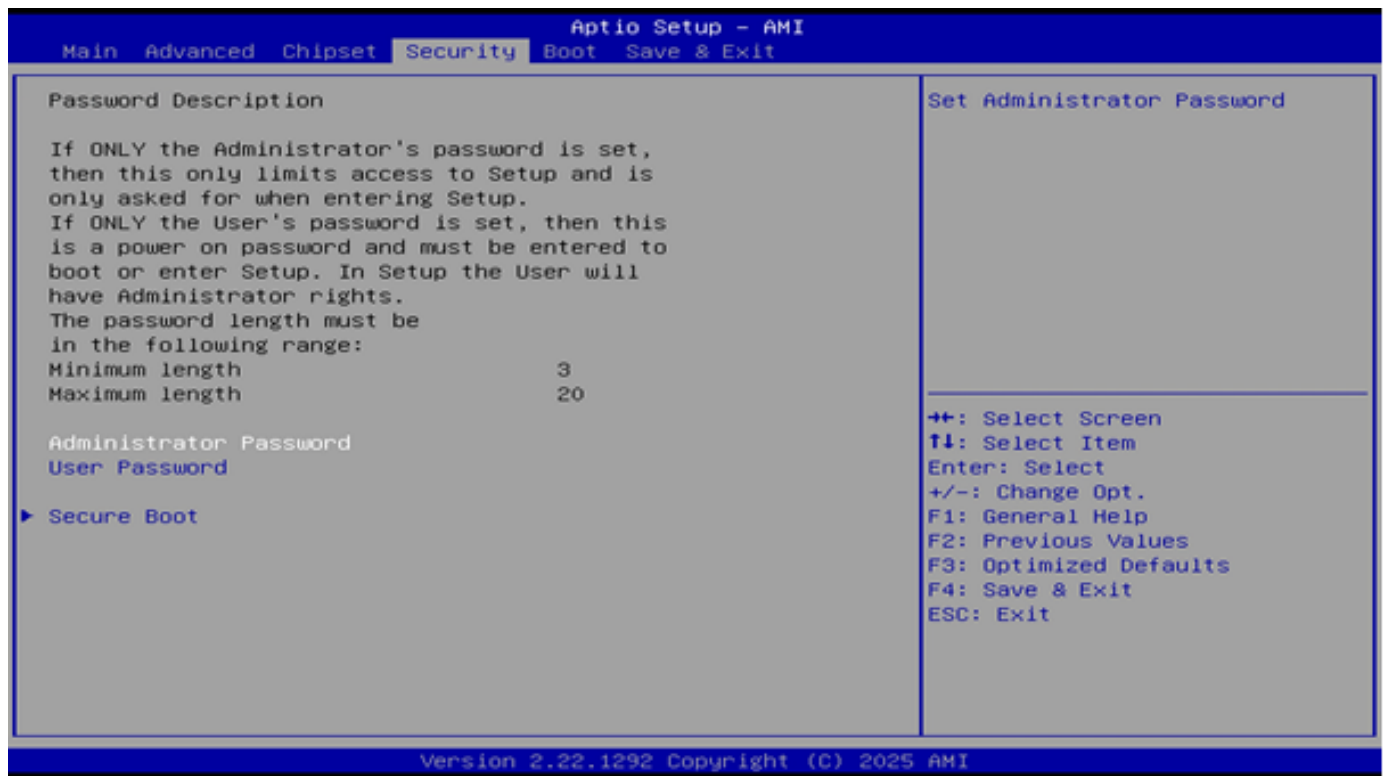

Security menu allow users to change administrator password and user password settings.

Administrator Password

If there is no password present on system, please press [Enter] to create new administrator password. If password is present on system, please press [Enter] to verify old password then to clear/change password. Press again to confirm the new administrator password.

User Password

If there is no password present on system, please press [Enter] to create new administrator password. If password is present on system, please press [Enter] to verify old password then to clear/change password. Press again to confirm the new administrator password.

▶ Secure Boot

Press [Enter] to make customized secure settings:

System Mode

Secure Boot

Secure Boot feature is Active if Secure Boot is Enabled, Platform Key(PK) is enrolled and the System is in User mode. The mode change requires platform reset.

The optional settings: [Disabled]; [Enabled].

Secure Boot Set the default value to: [Enabled]

Secure Boot Mode

Set UEFI Secure Boot Mode to Standard mode or Custom mode. This change is effective after save. After reset, this mode will return to Standard mode.

In Custom mode, Secure Boot Policy variables can be configured by a physically present user without full authentication.

The optional settings: [Standard]; [Custom].

Secure Boot Mode Set the default value to: [Standard]

When set as [**Custom**], user can make further settings in the following items that show up:

▶ **Restore Factory Keys**

Use this item to force system to User Mode, to install factory default Secure Boot key databases.

▶ **Reset To Setup Mode**

Use this item to Delete all secure boot key databases from NVRAM.

▶ **Key Management**

This item enables expert users to modify Secure Boot Policy variables without full authentication, which includes the following items:

Vendor Keys

Factory Key Provision

This item is for user to install factory default Secure Boot keys after the platform reset and while the System is in Setup mode.

The optional settings: [Disabled]; [Enabled].

Factory Key Provision Set the default value to: [Disabled]

▶ **Restore Factory Keys**

Use this item to force system into User Mode. Install factory default Secure Boot key databases.

▶ **Reset To Setup Mode**

Use this item to Delete all Secure Boot key databases from NVRAM.

▶ **Enroll Efi Image**

This item allows the image to run in Secure Boot mode.

Enroll SHA256 Hash certificate of a PE image into Authorized Signature Database (db).

▶ **Export Secure Boot variables**

Use this item to save NVRAM content of Secure Boot variables to a file.

▶ **Export Secure Boot variables**

▶ **Platform Key(PK)**

▶ **Key Exchange Keys(KEK)**

▶ **Signatures(db)**

▶ **Forbidden Signatures(dbx)**

▶ **Authorized TimeStamps(dbt)**

▶ **OsRecovery Signatures(dbr)**

Use this item to enroll Factory Defaults or load certificates from a file:

1. Public Key Certificate:

- a) EFI_SIGNATURE_LIST
- b) EFI_CERT_X509 (DER)
- c) EFI_CERT_RSA2048 (bin)
- d) EFI_CERT_SHAXXX

2. Authenticated UEFI Variable

3. EFI PE/COFF Image (SHA256)

Key Source: Factory, Modified, Mixed

3-10 Boot Menu

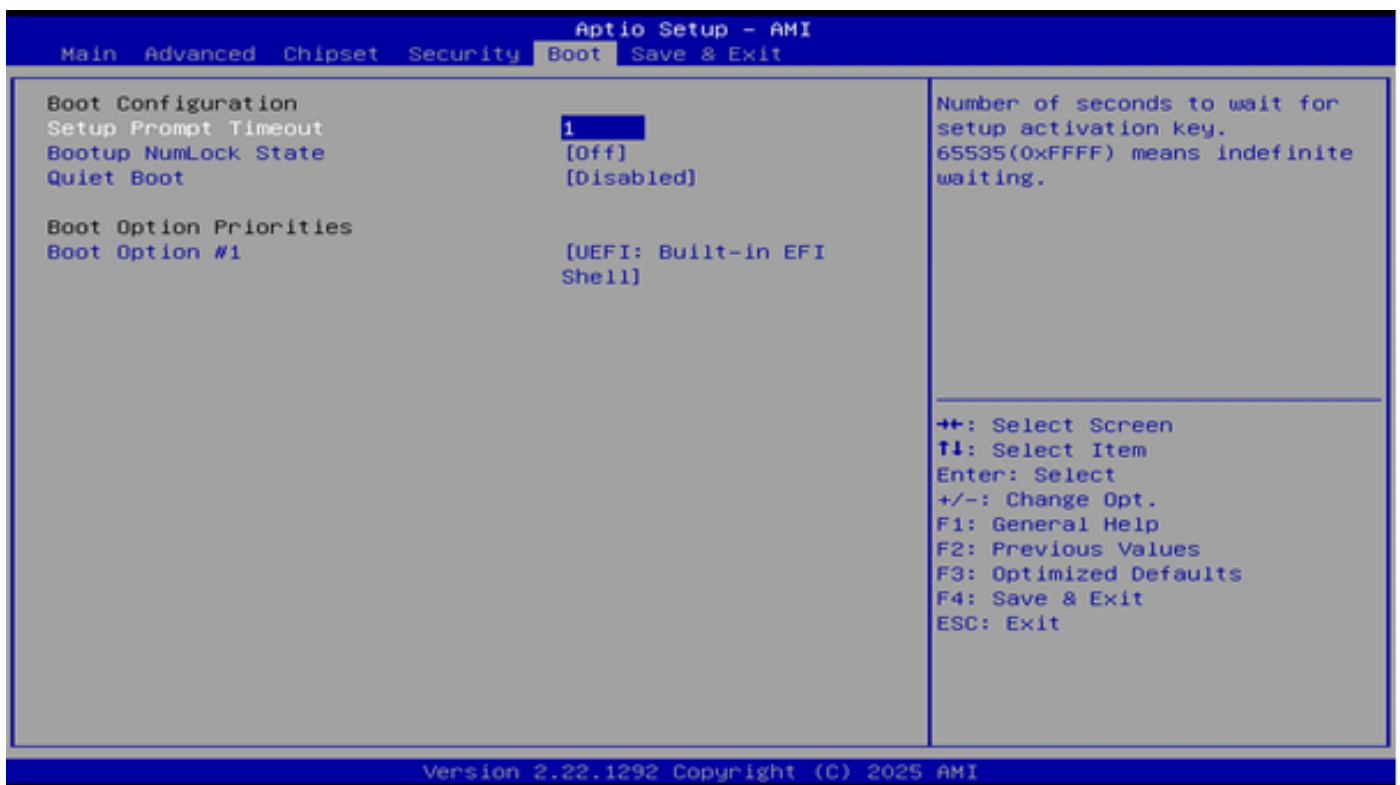

Boot Configuration

Setup Prompt Timeout

Use this item to set number of seconds to wait for setup activation key. 65535 (0xFFFF) means indefinite waiting.

Setup Prompt Timeout Set the default value to: [1]

Bootup NumLock State

Use this item to select keyboard NumLock state.

The optional settings: [On]; [Off].

Bootup NumLock State Set the default value to: [Off]

Quiet Boot

The optional settings: [Disabled]; [Enabled].

Quiet Boot Set the default value to: [Disabled]

Boot Option Priorities

3-11 Save & Exit Menu



Save Changes and Reset

This item allows user to reset the system after saving the changes.

Discard Changes and Reset

This item allows user to reset the system setup without saving any changes.

Restore Defaults

Use this item to restore /load default values for all the setup options.

Save as User Defaults

Use this item to save the changes done so far as user defaults.

Restore User Defaults

Use this item to restore the user defaults to all the setup options.

Boot Override

Appendix A

Mating Connectors

Location Printing	Function	Vendor	Vendor P/N
BATCON-1	RTC Battery Connector	Topt	WF125-102M-TFT0004D
FP_COM1	RS232/RS422/RS485 Serial Port Header	Topt	PH200-205M-GBB00010D
FP_COM2	RS232 Serial Port Header	Topt	PH200-205M-GBB00010D
FP_COM3	RS232 Serial Port Header	Topt	PH200-205M-GBB00010D
FP_COM4	RS232 Serial Port Header	Topt	PH200-205M-GBB00010D
FP_COM5	RS232 Serial Port Header	Topt	PH200-205M-GBB00010D
FP_COM6	RS232 Serial Port Header	Topt	PH200-205M-GBB00010D
CPUFAN	CPU FAN Connector	DCNT	W25M-04SST38SN02
DCIN	Internal 12V~28V Wide-Voltage Power Connector	DCNT	1-1123723-2
DCIN1	12V~28V Wide-Voltage Power Connector	盛聰	DJ-D020A
FP_AUDIO1	Front Panel Line-Out, MIC-In Audio Header	Topt	PH200-205S-GBB0008A
FP_USB21	USB 2.0 Port Header	Topt	PH200-205M-GBB0009D
FP_USB22	USB 2.0 Port Header	Topt	PH200-205M-GBB0009D
GPIO	GPIO/80 Port Header	Kunguang	PH2.0 2*5P SQ8.1/5.8(0)/4.2 SMT
INVERTER	LVDS/eDP Inverter Wafer	Topt	WF2-1108-K-S6R-B0
JW_FP	Front Panel Function Header	Topt	PH254-204S-GB0004A
LVDS_EDP	LVDS/EDP LCD Header	Topt	XM
SATA1	SATA3 Port Connector	WIN WIN	WAT3M-07A1G3BU4W
SATAPWR	SATA HDD Power-Out Connector	Topt	WF5-11XX-Q-S6W-B0
SMBUS	SMBUS Header	Topt	PH200-A105-SGCB-RN
SPK_CON	3W Amplifier Wafer	Topt	WF2-1104-S6W-B0

Appendix B

I/O Address Map

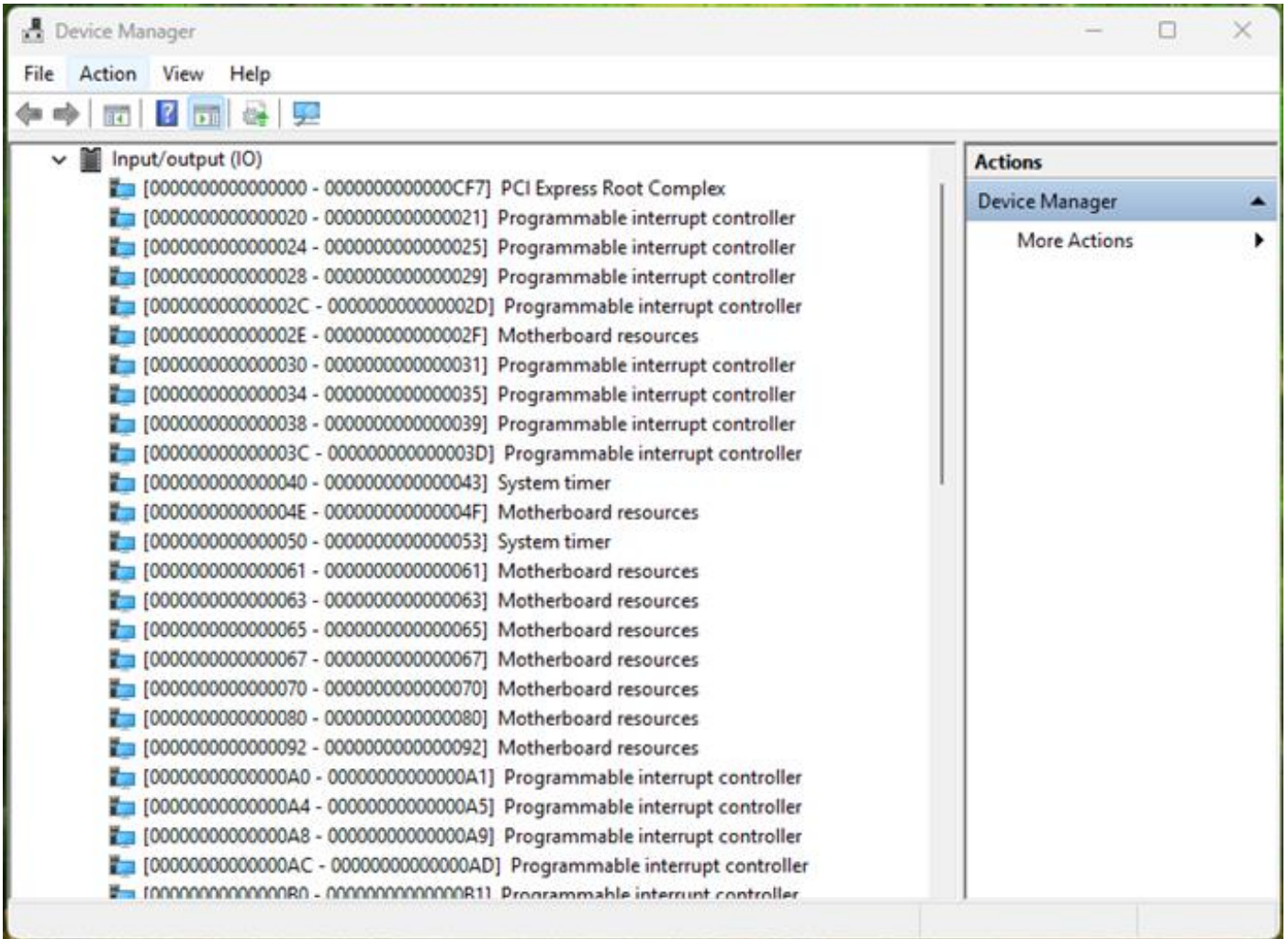

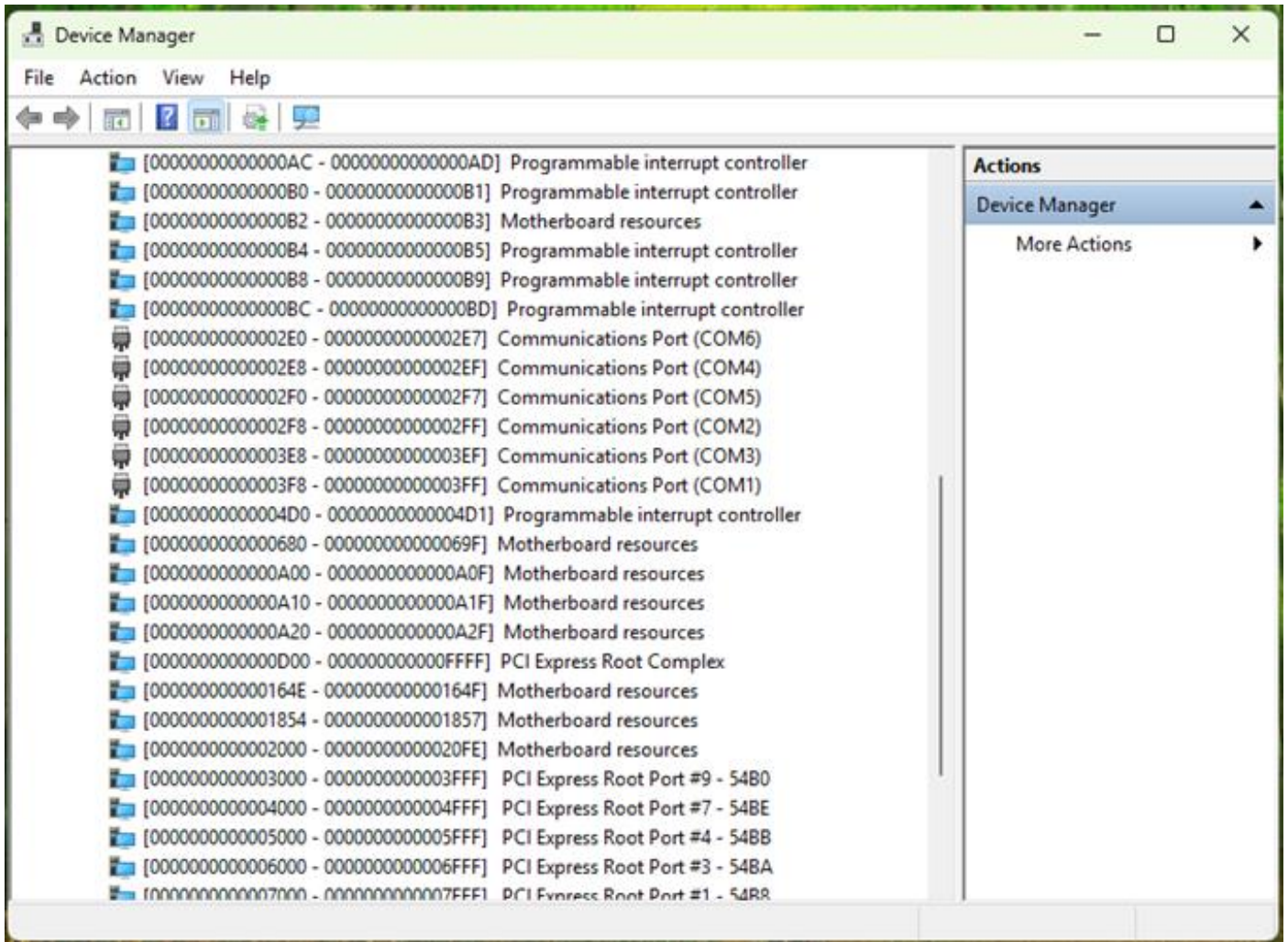

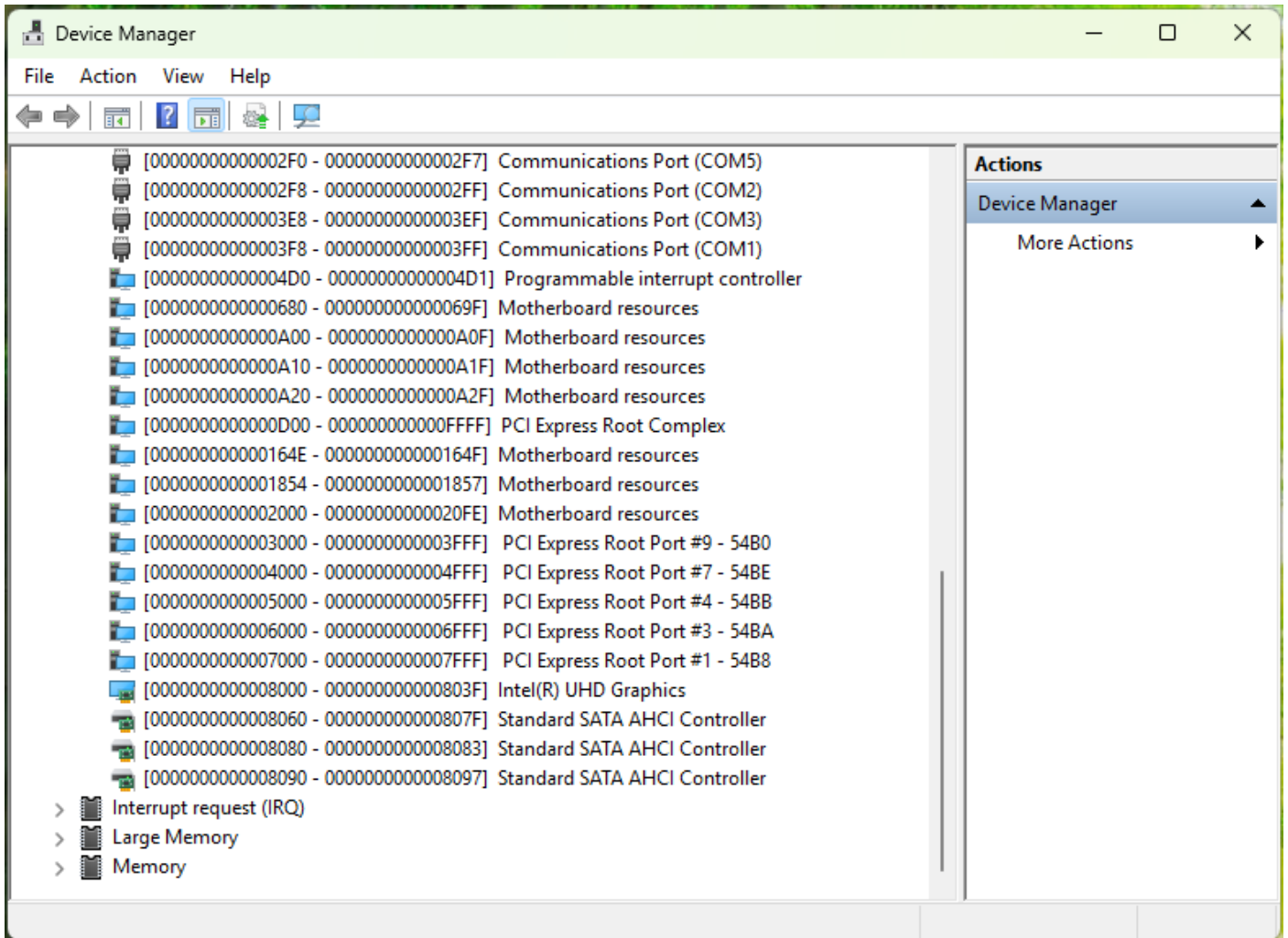

Memory Address Map

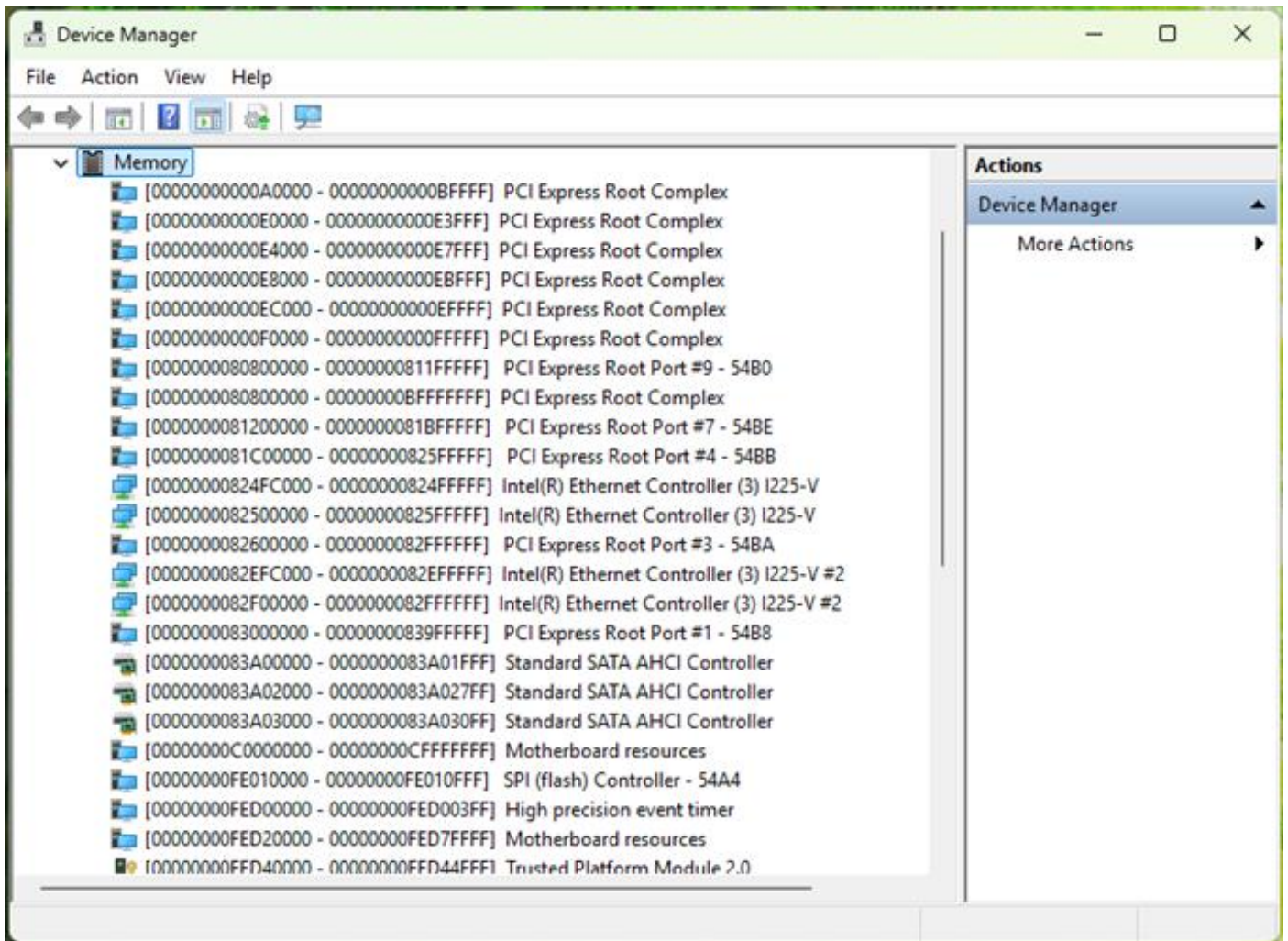

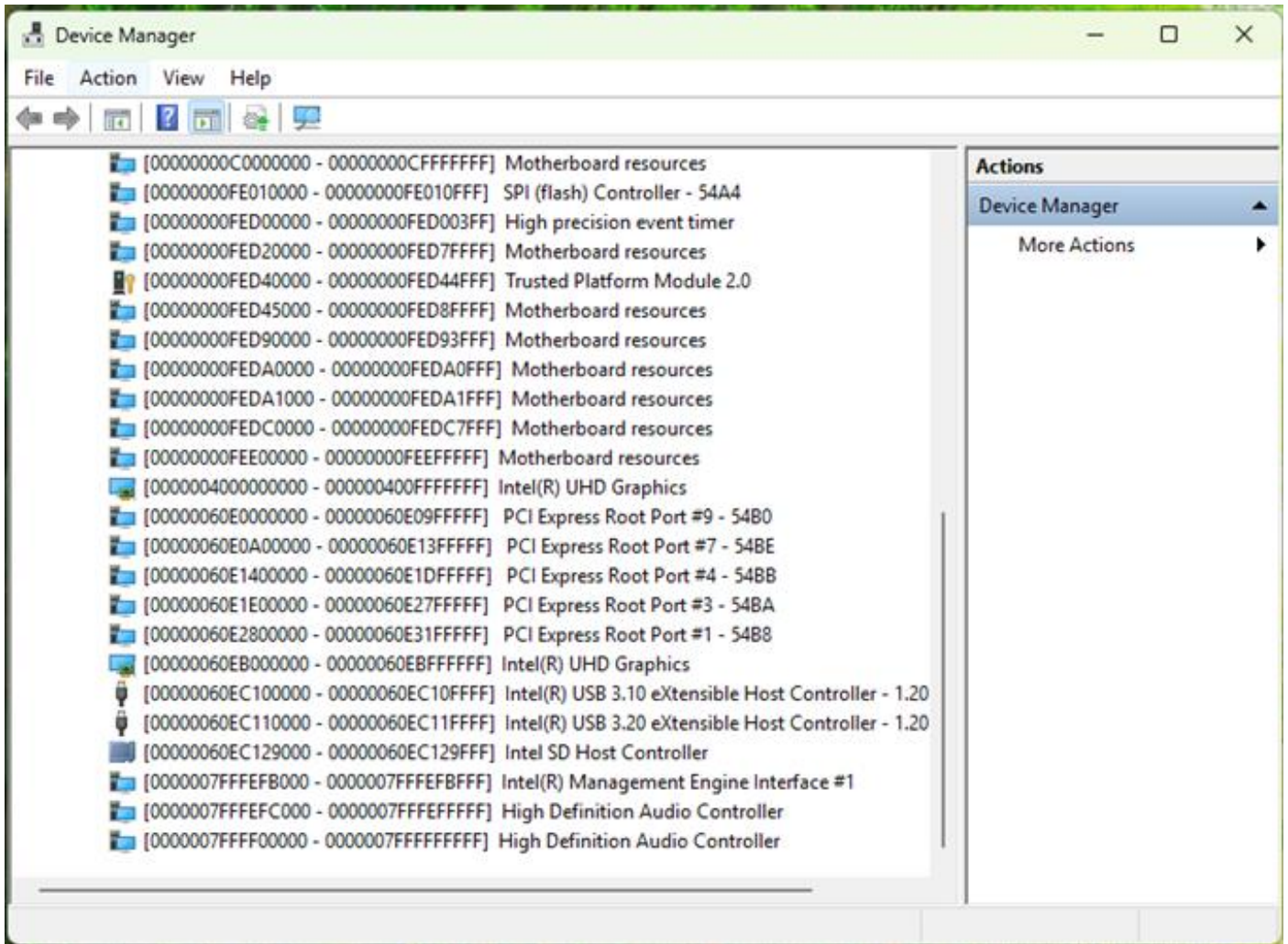

IRQ Mapping Chart

