

MI215 Series

User's Manual

NO. G03-MI215-F

Revision: 3.0

Release date: July 9, 2024

Trademark:

* Specifications and Information contained in this documentation are furnished for information use only, and are subject to change at any time without notice, and should not be construed as a commitment by manufacturer.

Environmental Protection Announcement

Do not dispose this electronic device into the trash while discarding. To minimize pollution and ensure environment protection of mother earth, please recycle.



TABLE OF CONTENT

ENVIRONMENTAL SAFETY INSTRUCTION.....	iii
USER'S NOTICE	iv
MANUAL REVISION INFORMATION	iv
ITEM CHECKLIST	iv
CHAPTER 1 INTRODUCTION OF THE MOTHERBOARD	
1-1 FEATURE OF MOTHERBOARD	1
1-2 SPECIFICATION	2
1-3 LAYOUT DIAGRAM	4
CHAPTER 2 HARDWARE INSTALLATION	
2-1 JUMPER SETTING.....	10
2-2 CONNECTORS, HEADERS AND WAFERS.....	14
2-2-1 REAR I/O BACK PANEL CONNECTORS	14
2-2-2 MOTHERBOARD INTERNAL CONNECTORS	17
2-2-3 PIN DEFINITION FOR HEADERS & WAFERS.....	19
2-3 MAXIMUM VOLTAGE & CURRENT LIMIT	26
CHAPTER 3 INTRODUCING BIOS	
3-1 ENTERING SETUP.....	27
3-2 BIOS MENU SCREEN.....	28
3-3 FUNCTION KEYS.....	29
3-4 GETTING HELP	29
3-5 MENU BARS	30
3-6 MAIN MENU	30
3-7 ADVANCED MENU	31
3-8 CHIPSET MENU.....	45
3-9 SECURITY MENU	48
3-10 BOOT MENU	50
3-11 SAVE & EXIT MENU	51
3-12 MEBX.....	52



Environmental Safety Instruction

- Avoid the dusty, humidity and temperature extremes. Do not place the product in any area where it may become wet.
- 0 to 40 centigrade is the suitable temperature. (The temperature comes from the request of the chassis and thermal solution)
- Generally speaking, dramatic changes in temperature may lead to contact malfunction and crackles due to constant thermal expansion and contraction from the welding spots' that connect components and PCB. Computer should go through an adaptive phase before it boots when it is moved from a cold environment to a warmer one to avoid condensation phenomenon. These water drops attached on PCB or the surface of the components can bring about phenomena as minor as computer instability resulted from corrosion and oxidation from components and PCB or as major as short circuit that can burn the components. Suggest starting the computer until the temperature goes up.
- The increasing temperature of the capacitor may decrease the life of computer. Using the close case may decrease the life of other device because the higher temperature in the inner of the case.
- Attention to the heat sink when you over-clocking. The higher temperature may decrease the life of the device and burned the capacitor.

USER'S NOTICE

COPYRIGHT OF THIS MANUAL BELONGS TO THE MANUFACTURER. NO PART OF THIS MANUAL, INCLUDING THE PRODUCTS AND SOFTWARE DESCRIBED IN IT MAY BE REPRODUCED, TRANSMITTED OR TRANSLATED INTO ANY LANGUAGE IN ANY FORM OR BY ANY MEANS WITHOUT WRITTEN PERMISSION OF THE MANUFACTURER.

THIS MANUAL CONTAINS ALL INFORMATION REQUIRED TO USE THIS MOTHER-BOARD SERIES AND WE DO ASSURE THIS MANUAL MEETS USER'S REQUIREMENT BUT WILL CHANGE, CORRECT ANY TIME WITHOUT NOTICE. MANUFACTURER PROVIDES THIS MANUAL "AS IS" WITHOUT WARRANTY OF ANY KIND, AND WILL NOT BE LIABLE FOR ANY INDIRECT, SPECIAL, INCIDENTAL OR CONSEQUENTIAL DAMAGES (INCLUDING DAMAGES FOR LOSS OF PROFIT, LOSS OF BUSINESS, LOSS OF USE OF DATA, INTERRUPTION OF BUSINESS AND THE LIKE).

PRODUCTS AND CORPORATE NAMES APPEARING IN THIS MANUAL MAY OR MAY NOT BE REGISTERED TRADEMARKS OR COPYRIGHTS OF THEIR RESPECTIVE COMPANIES, AND THEY ARE USED ONLY FOR IDENTIFICATION OR EXPLANATION AND TO THE OWNER'S BENEFIT, WITHOUT INTENT TO INFRINGE.

Manual Revision Information

Reversion	Revision History	Date
4.0	Fourth Edition	July 9, 2024

Item Checklist

- Motherboard
- Cable(s)
- I/O Back panel shield

Chapter 1

Introduction of the Motherboard

1-1 Feature of Motherboard

- Intel® LGA1700 Socket supports 12th /13th /14th Gen. Core Processor (**Max. 65W TDPs under 180A**)
- Support 2* DDR5 4800MHz SO-DIMM up to 96GB
- Integrated with 2* Intel® 2.5GbE PCIe LAN chips
- 2* HDMI, 2* DP, 1* LVDS/eDP Output
- Support 6* COM Serial Ports (2*RS232/422/485 & 4* RS232)
- **MI215Q6700/R6800 series:** total support up to 4* USB3.2 (Gen.2), 2* USB3.2 (Gen.1), 4* USB2.0 ports
- **MI215H6100 series:** total support up to 2* USB3.2 (Gen.2), 1* USB3.2 (Gen.1), 3* USB2.0 ports
- **MI215Q6700/R6800 series:** 2 * SATAIII (6Gb/s) ports with support for RAID 0, 1 mode & 2* M.2 (M-key) slots; 1* M.2 (E-key) & 1* M.2 (B-key) slot along with SIM card holder; 1* PCIe Gen.4 x16 slot
- **MI215H6100 series:** 2* SATAIII (6Gb/s) ports & 1* M.2 (M-key) slot; 1* M.2 (E-key) & 1* M.2 (B-key) slot along with SIM card holder; 1* PCIe Gen.4 x16 slot
- Support onboard TPM 2.0 (***optional to MI215R6802/Q6702/H6102 Series**)
- Support wide voltage 12V~36V DC-in
- Support Smart FAN function
- Supports ACPI S3 Function
- Compliance with ErP Standard
- Support Watchdog Timer Technology

1-2 Specification

Spec	Description
Design	<ul style="list-style-type: none"> ● Slim Mini-ITX form factor; 10-layers; PCB size: 17.0x17.0cm
Chipset	<ul style="list-style-type: none"> ● MI215H6100 Series: Intel® H610E/H610 Chipset (Default: H610) ● MI215Q6700 Series: Intel® Q670E Chipset ● MI215R6800 Series: Intel® R680E Chipset
CPU Socket	<ul style="list-style-type: none"> ● Intel® LGA 1700 Socket supports 12th/13th/14th Gen. Core™ processors (Max. 65W TDPs under 180A) <p><i>*Note: for detailed CPU support information please visit our website.</i></p>
Memory Slot	<ul style="list-style-type: none"> ● 2* DDR5 SO-DIMM slot ● Support 2* DDR5 4800MHz SO-DIMM up to 96GB ● Support dual channel function <p><i>*Note: MI215R6800 series support ECC.</i></p>
Expansion Slot	<ul style="list-style-type: none"> ● PCIE1:1* PCIe Gen.4 x16 slot (Max.70W) ● M2E1:1* M.2 E-key, type-2230 slot(USB2.0/PCIe x1 interface) supports CNVio for Wi-Fi ● M2B1:1* M.2 B-key, type-3042/3052 slot (USB3.1 /USB2.0/ PCIe x1 interface) for 4G/5G Module ● SIMCARD B1:1* Nano-SIM card slot; co-function with M2B1 slot
Storage	<ul style="list-style-type: none"> ● 2*SATAIII 6Gb/s port (*SATA1/2) <p><i>*Note: MI215Q6700/R6800 series support RAID 0/1 mode.</i></p> <ul style="list-style-type: none"> ● M2M1: 1* M.2 M-key, type-2280 slot (PCIe Gen.3x4/SATA interface) supports NVMe ● *M2M2:1* M.2 M-Key, type-2242 slot (PCIe Gen.4x4/SATA interface) supports NVMe <p><i>*Note: M2M2 slot is only available to MI215Q6700/R6800 series.</i></p>
Graphics	<p>Intel® UHD Graphics, shared memory for:</p> <ul style="list-style-type: none"> ● 2* DP 1.4a ● 2* HDMI 2.0b ● 1* LVDS/eDP <p><i>* Note: MI215Q6700/R6800 series support Quad Displays; MI215H6100 series support Triple Displays</i></p>
LAN Chips	<p>Integrated with:</p> <ul style="list-style-type: none"> ● MI215R6800 & MI215Q6700:1* Intel i225-LM +1* Intel i225-V 2.5GbE PCIe LAN chip

	<ul style="list-style-type: none"> ● MI215H6100: 2* Intel i225-V 2.5GbE PCIe LAN chip ● Support 10/100/1000/2500Mbps Ethernet data transfer rate <p>*Note: 2500Mbps high-speed transmission rate is <i>only</i> supported over CAT 5e UTP cable.</p>
Audio Chip	<ul style="list-style-type: none"> ● Realtek HD Audio Codec integrated ● Audio driver and utility included
BIOS	<ul style="list-style-type: none"> ● AMI 256Mb Flash ROM
Multi I/O	<p>Rear Panel I/O:</p> <ul style="list-style-type: none"> ● MI215Q6700/R6800: 4* USB 3.2 Gen.2 port ● MI215H6100: 2* USB 3.2 Gen.2 port & 1* USB 3.2 Gen.1 port + 1* USB 2.0 port ● 2* 2.5GbE RJ-45 LAN port ● 2* DP1.4a port ● 2* HDMI 2.0b port ● 1* Audio jack (Line-out/MIC combo) ● 1* 4-Pin 12V~36V Mini-DIN DC-in power jack <p>Internal I/O Connectors, Headers & Wafers:</p> <ul style="list-style-type: none"> ● 1* 12V~36V internal ATX-type power connector (DCIN2) ● 1 * SATA HDD power-out connector ● 1* CPUFAN1 connector ● 1* CMOS battery connector ● 1* Front panel header ● 1* Front panel audio header ● 1* 3W 8Ω amplifier wafer (SPEAK_CON) ● 2* RS232/422/485 serial port header (COM1/2) ● 4* RS232 serial port header (COM3/4/5/6) ● MI215Q6700/R6800: 2* USB 3.2 (Gen.1) port (FP_USB3)+ 4* USB 2.0 port (FP_USB1/2) ● MI215H6100: 2* USB 2.0 port (FP_USB1) ● 1* GPIO/80 port header ● 1* SMBUS header ● 1* LVDS/EDP wafer (LVDS_EDP) & 1*Inverter wafer(INVERTER1)
TPM 2.0	<ul style="list-style-type: none"> ● Optional for MI215R6802, MI215Q6702 & MI215H6102 Series
OS Support	<ul style="list-style-type: none"> ● <i>for detailed OS support information please visit our website for latest update</i>

1-3 Layout Diagram

Rear IO Diagram

For MI215R6800/ MI215Q6700 Series:

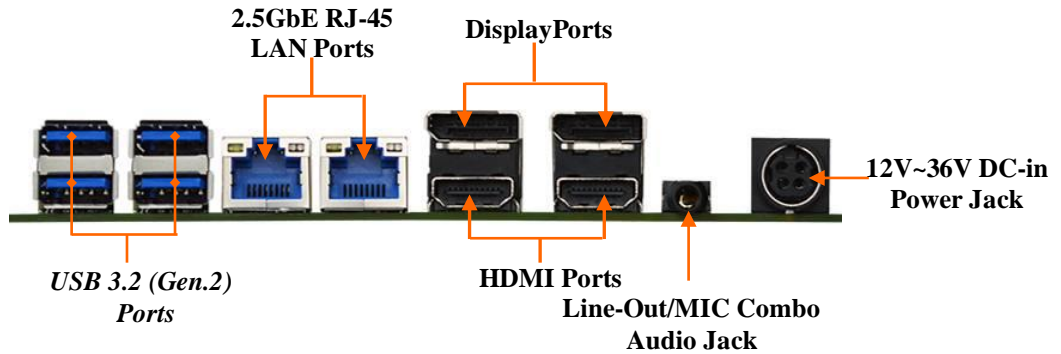

For MI215H6100 Series:

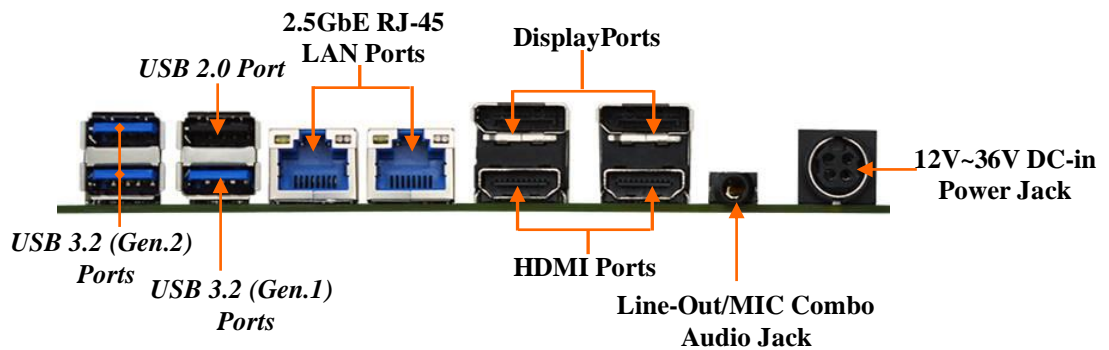

Warning!!

The board has a 12V~36V DC-in power connector (**DCIN3**) on I/O back panel and an internal 12V~36V power connector (**DCIN2**). User can only connect one type of compatible power supply to one of them to power the system.

Motherboard Internal Diagram-Front

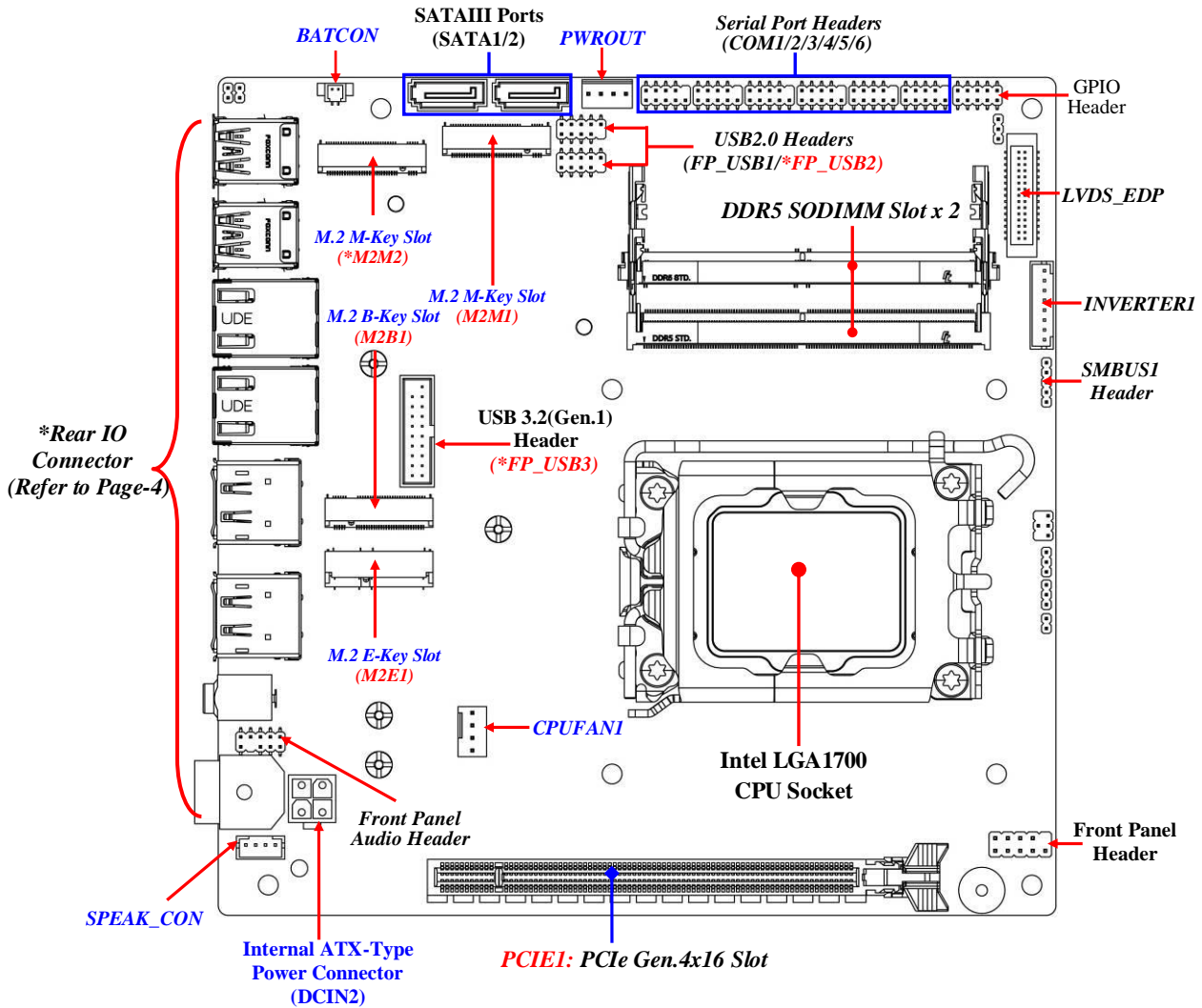

***Note:** M2M2 Slot, FP_USB2 & FP_USB3 headers are only available to MI215Q6700/R6800 series.

Motherboard Internal Diagram-Back

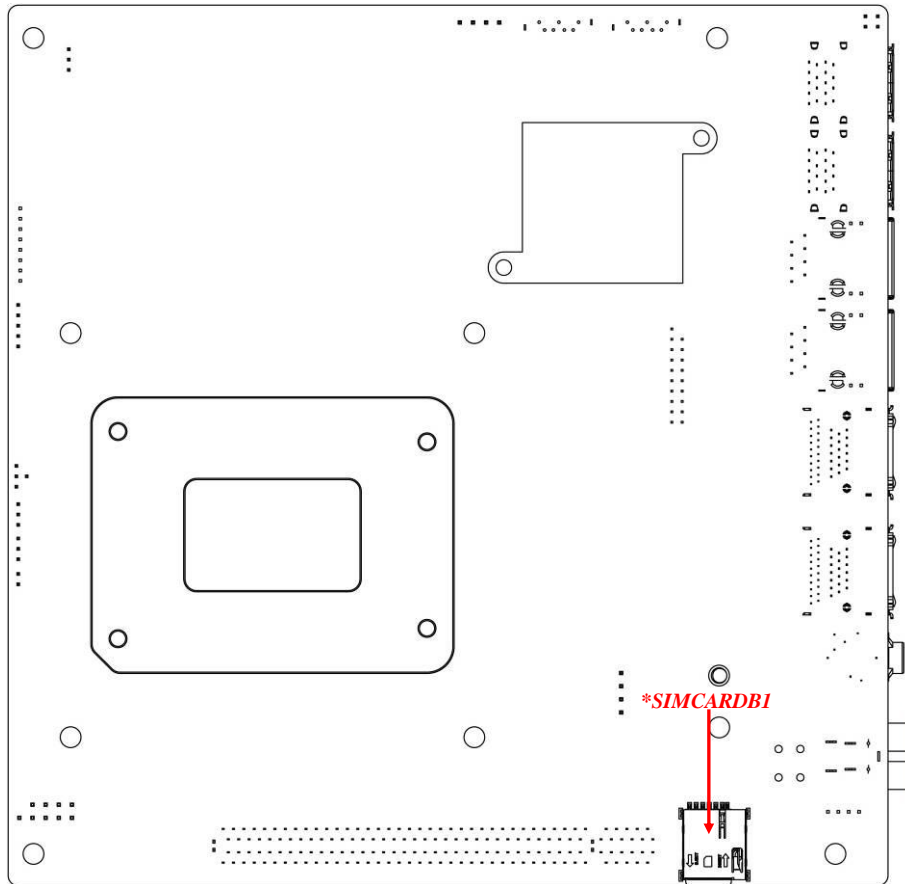

***Note:** SIM card slot only workable along with M.2 B-key slot.

Motherboard Jumper Position

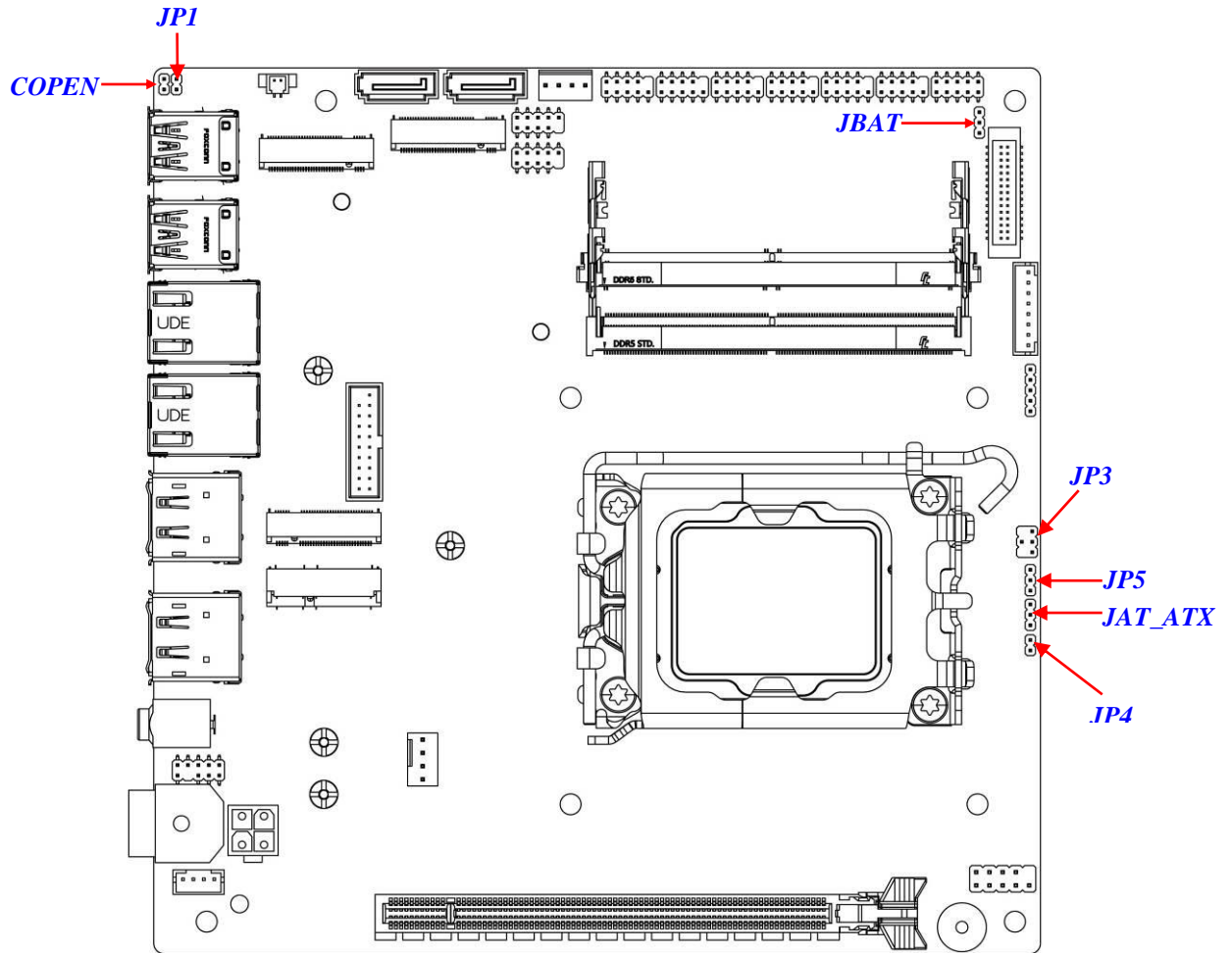

***Note:** The diagrams in the manual are mostly taken from **MI215Q6700/R6800** series for illustration purpose, unless otherwise stated.

Jumper

P/N	Name	Description	Pitch
JBAT	Clear CMOS RAM Settings	3-pin Block	2.0mm
JP1	ME_Features Select	2-pin Block	2.0mm
COPEN	Case Open Message Display Function	2-pin Block	2.0mm
JP3	LVDS_EDP VDD Select	4-pin Block	2.0mm
JP5	INVERTER1 Backlight VCC Select	3-pin Block	2.0mm
JAT_ATX	ATX Mode / AT Mode Select	3-pin Block	2.0mm
JP4	GPIO Header Function Select	2-pin Block	2.0mm

Connectors

P/N	Name
USB1	USB 3.2(Gen.2) Port X2
MI215Q6700/R6800:USB2	USB 3.2(Gen.2) Port X2
MI215H6100:USB2	Top: USB 2.0 Port Bottom: USB 3.2(Gen.1) Port
LAN1/LAN2	2.5 GbE RJ-45 LAN Port
DP_HDMI1/ DP_HDMI2	Top: DisplayPort (DP1.4a) Bottom: HDMI Port (HDMI 2.0b)
AUDIO	Line-out/MIC Combo Audio Jack
DCIN3	12V~36V Mini-DIN DC-In Power Jack
DCIN2	Internal 12V~36V ATX-type Power Connector
SATA1/2/3/4	SATAIII Connector
PWROUT	SATA HDD Power-Out Connector
CPUFAN1	CPU Fan Connector
BATCON	CMOS Battery Connector

Headers & Wafers

P/N	Name	Description	Pitch
FP (Front Panel Header)	PWR LED/ HD LED/Power Button /Reset	9-pin Block	2.54mm
FP_AUDIO	Front Panel Audio Header	9-pin Block	2.0mm
SPEAK_CON	3W 8 Ω Amplifier Wafer	4-pin Block	2.0mm
COM1/2	RS232/422/485 Serial Port Header	9-pin Block	2.0mm
COM3/4/5/6	RS232 Serial Port Header	9-pin Block	2.0mm
FP_USB1	USB2.0 Port Header	9-pin Block	2.0mm
MI215Q6700/R6800: FP_USB2	USB2.0 Port Header	9-pin Block	2.0mm
MI215Q6700/R6800: FP_USB3	USB 3.2 (Gen.1) Port Header	19-pin Block	2.0mm
GPIO	GPIO/80Port Header	10-pin Block	2.0mm
SMBUS1	SMBUS Header	5-pin Block	2.0mm
LVDS_EDP	LVDS/EDP Wafer	30-pin Block	1.25mm
INVERTER1	Inverter Wafer	8-pin Block	2.0mm

Chapter 2

Hardware Installation

2-1 Jumper Setting

JBAT (3-pin): Clear CMOS RAM Settings

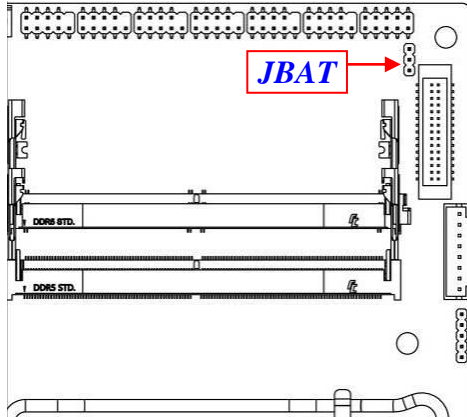

JBAT → Clear CMOS RAM Settings

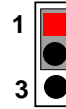

1-2 Closed: Normal(**default**);



2-3 Closed: Clear CMOS.

JP1 (2-pin): ME_Features Select

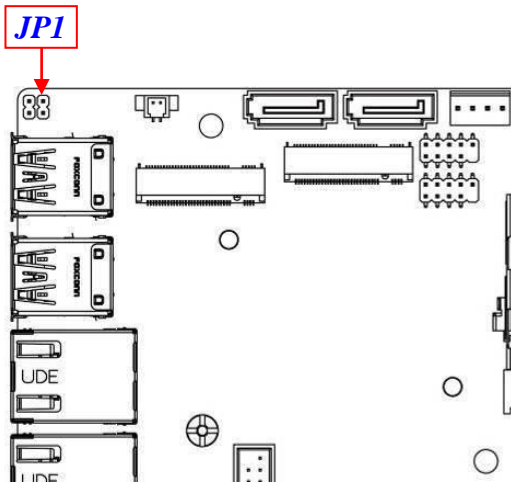

JP1 → ME_Features Select

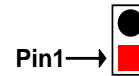

1-2 Open: Enable ME_Features(**default**);

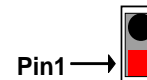

1-2 Closed: Disable ME_Features.

COPEN (2-pin): Case Open Message Display Function

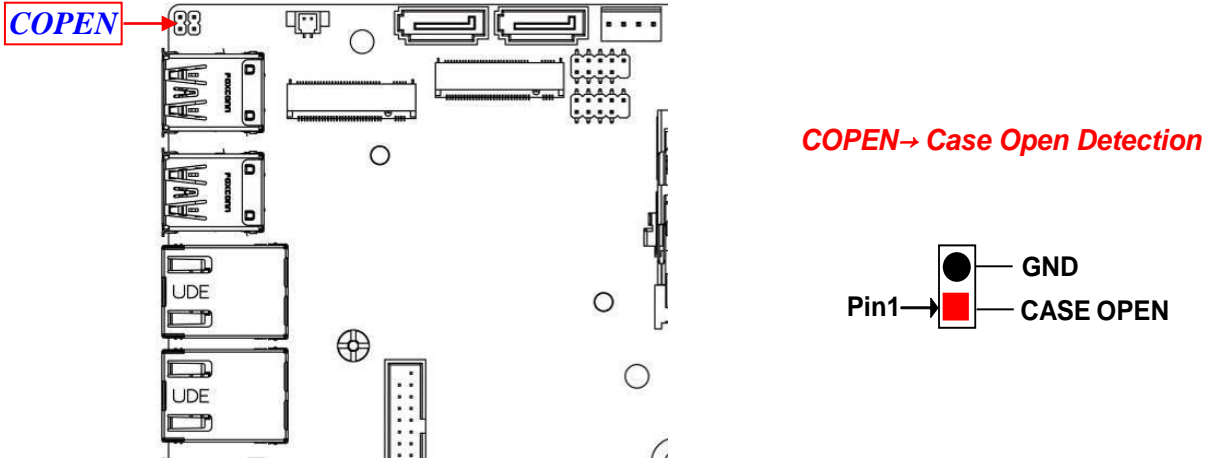

Pin 1-2 Short: When Case open function pin short to GND, the Case open function was detected. When Used, needs to enter BIOS and enable 'Case Open Detect' function. In this case if your case is removed, next time when you restart your computer, a message will be displayed on screen to inform you of this.

JP3 (4-pin): LVDS_EDP VDD Select

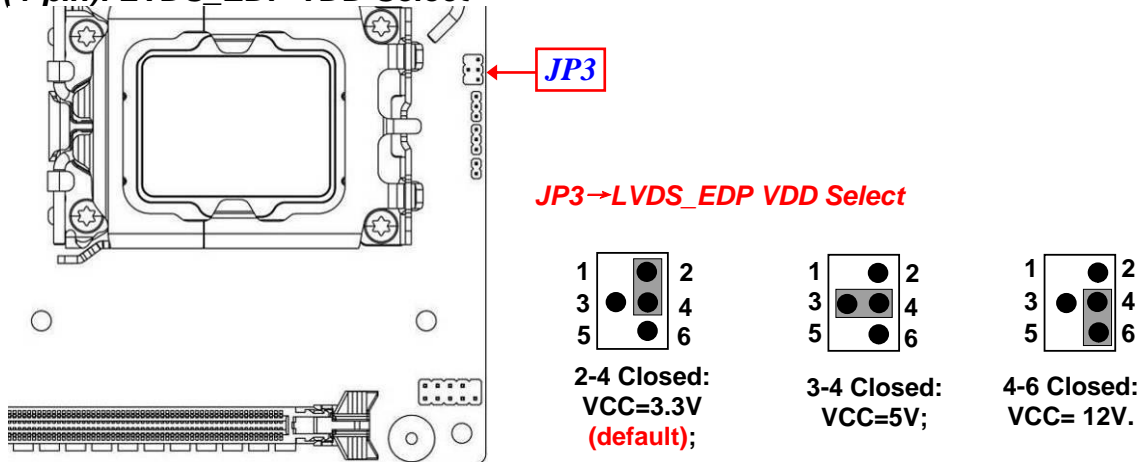

****Warning!** Wrong voltage setting will result in screen burn out.

JP5(3-pin):INVERTER1 Backlight VCC Select

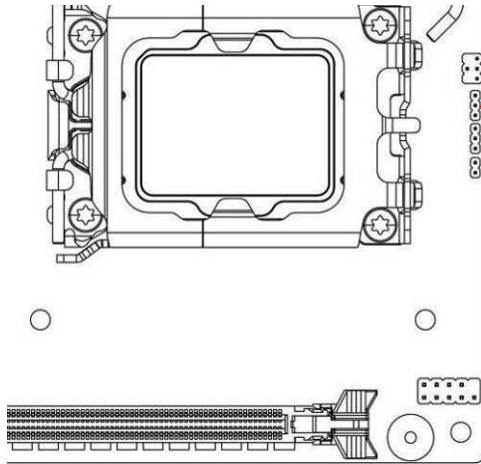

JP5→INVERTER1 Backlight VCC Select

JP5

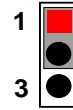

1-2 Closed: VCC=5V(**default**);

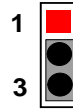

2-3 Closed: VCC=12V.

****Warning!** Wrong voltage setting will result in screen burn out.

JAT_ATX (3-pin): AT Mode /ATX Mode Select

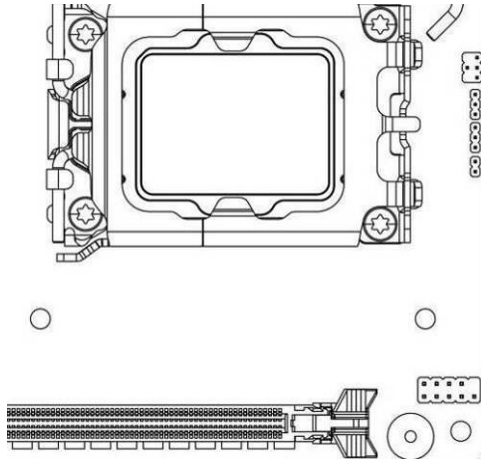

JAT_ATX→ATX/AT Mode Select

JAT_ATX



1-2 Closed: ATX Mode Selected(**default**);

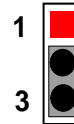

2-3 Closed: AT Mode Selected.

***ATX Mode Selected:** Press power button to power on after power input ready;

AT Mode Selected: Directly power on as power input ready.

JP4(2-pin): GPIO Header Function Select

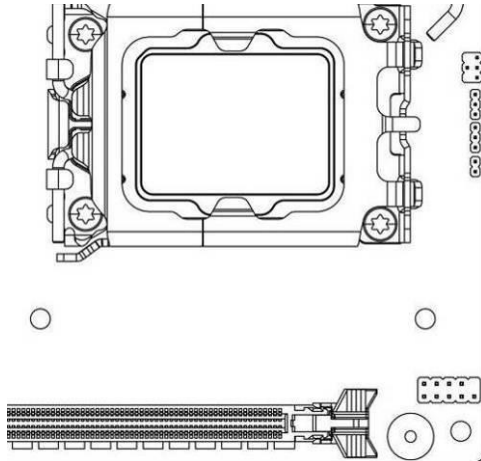

JP4→GPIO Function Select

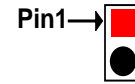

1-2 Open: Function as 80 Port;

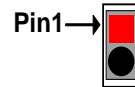







1-2 Closed: Function as GPIO Port(**default**).

2-2 Connectors, Headers & Wafers

2-2-1 Rear I/O Back Panel Connectors

**Refer to Page-4 Rear IO Diagram*

<i>Icon</i>	<i>Name</i>	<i>Function</i>
	<p align="center">USB 3.2 (Gen.2) Port</p>	<p>To connect USB keyboard, mouse or other devices compatible with USB 3.2 (Gen.2) specification. Ports support up to 10Gbps data transfer rate.</p>
	<p align="center">Top: USB 2.0 Port Bottom: USB 3.2 (Gen.1) Port</p>	<p>Top: To connect USB keyboard, mouse or other devices compatible with USB 2.0 specification. Bottom: To connect USB keyboard, mouse or other devices compatible with USB 3.2 (Gen.1) specification.</p>
	<p align="center">Display1.4a Port</p>	<p>Top: To connect display device that support DP1.4a specification.</p>
	<p align="center">HDMI2.0b Port</p>	<p>Bottom: To connect display device that support HDMI2.0b specification.</p>

	Line_Out/MIC Combo Audio Jack	This connector can functions as audio Line-Out jack and MIC jack with compatible cables & devices.
	Mini-DIN Power Jack	For user to connect compatible power adapter to provide power supply for the system.
	2.5Gbps RJ-45 LAN Port	This connector is standard RJ-45 LAN jack for Network connection which supports 10/100/1000/2500 Mbps Ethernet data transfer rate (*Note: 2.5Gbps is only supported with CAT 5e UTP cable).

(1) 2.5GbE RJ-45 Ethernet Connectors

** There are two LED next to the RJ-45 LAN port. Please refer to the table below for LAN port LED indications.

2.5Gbps RJ-45 LAN port LED Signals:

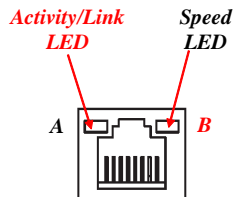

A: Activity/Link LED

Status	Description
Off	No Link
Blinking	Data Activity
On	Link

B: Speed LED

Status	Description
Off	10/100Mbps connection
Orange	1Gbps connection
Green	2.5Gbps connection

*** Note:** 2.5Gbps high-speed transmission rate is **only** supported over **CAT 5e UTP cable**.

(2) DCIN3: Mini-DIN 12V~36V Wide-Voltage DC-In Power Connector

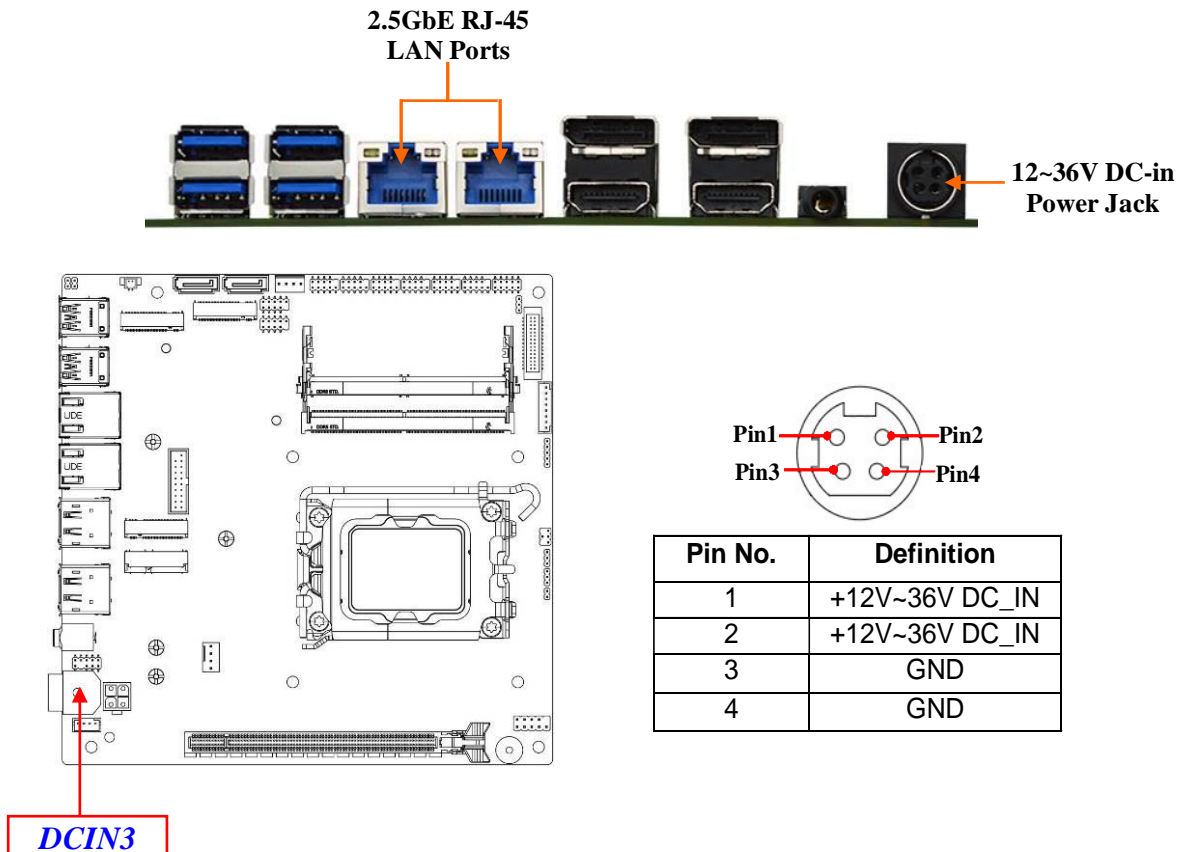

Warning!!

The board has a 12V~36V DC-in power connector (**DCIN3**) on I/O back panel and an internal 12V~36V power connector (**DCIN2**). User can only connect one type of compatible power supply to one of them to power the system.

2-2-2 Motherboard Internal Connectors

(1) DCIN2 (4-pin block): Internal 12V~36V Wide-Voltage Power Connector

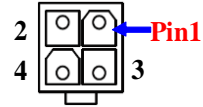
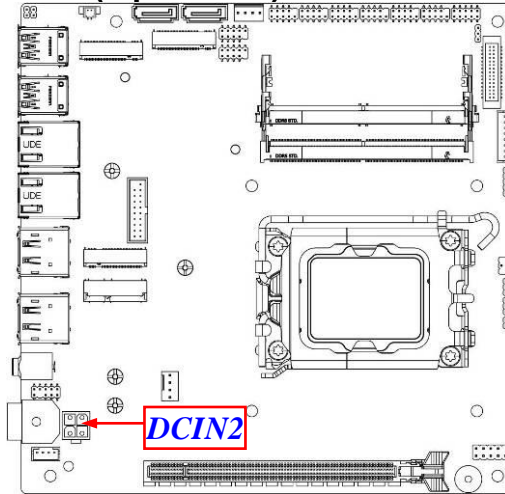

Pin No.	Definition
1	GND
2	GND
3	+12V~36V
4	+12V~36V

(2) SATA1/2 (7-pin): SATA III Port connector

These are high-speed SATAIII port that supports 6 GB/s transfer rate.

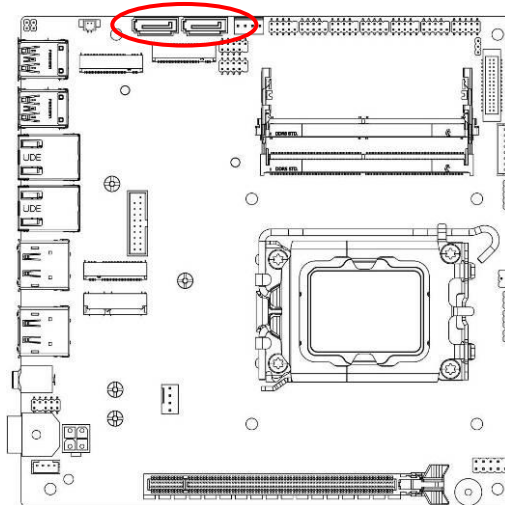

Pin No.	Definition
1	GND
2	TXP
3	TXN
4	GND
5	RXN
6	RXP
7	GND

(3) PWROUT (4-pin): HDD Power-Out connector

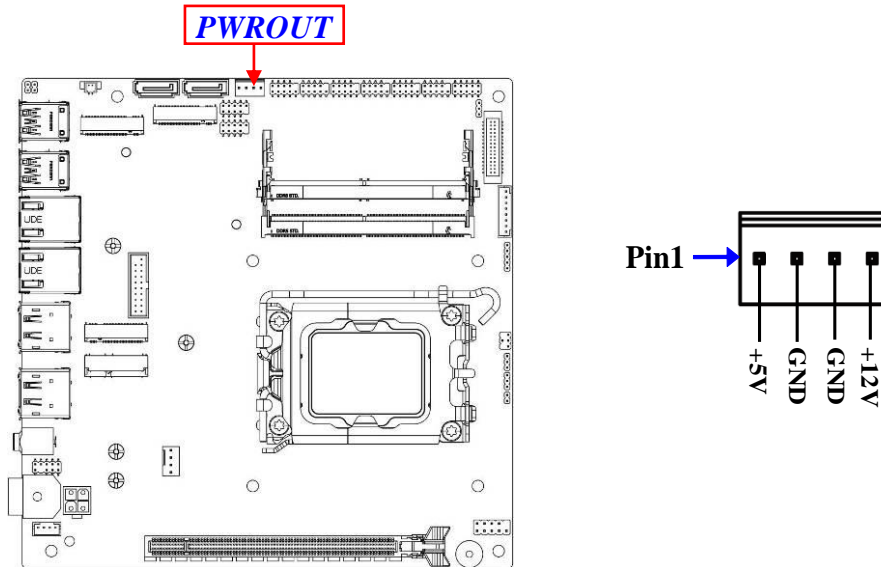

(4) CPUFAN1 (4-pin): CPU FAN Connector

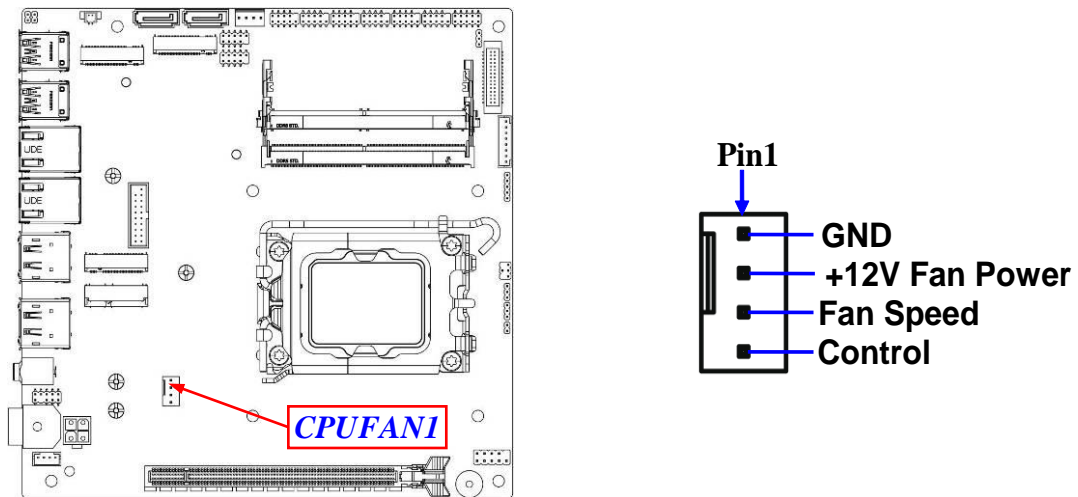

(5) BATCON (2-pin): Battery Connector

BATCON

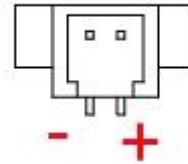
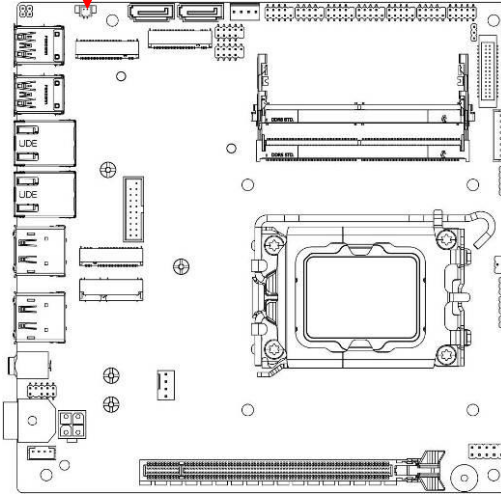

2-2-3 Pin Definition for Headers & Wafers

FP (9-pin): Front Panel Header

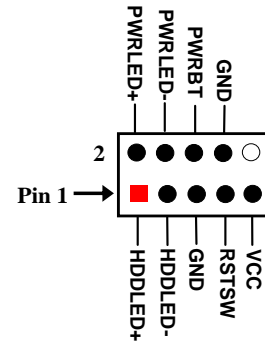
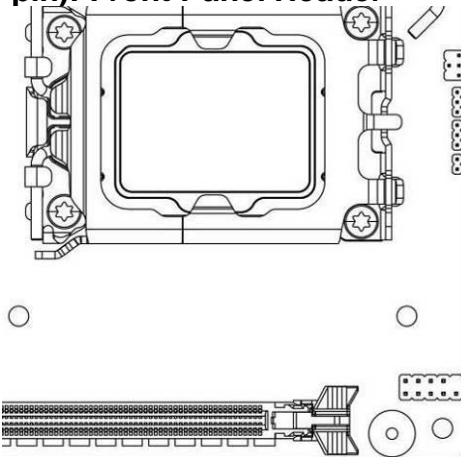

FP_AUDIO (9-pin): Line-Out, MIC-In Header

This header is connected to Front Panel Line-out, MIC connector with cable.

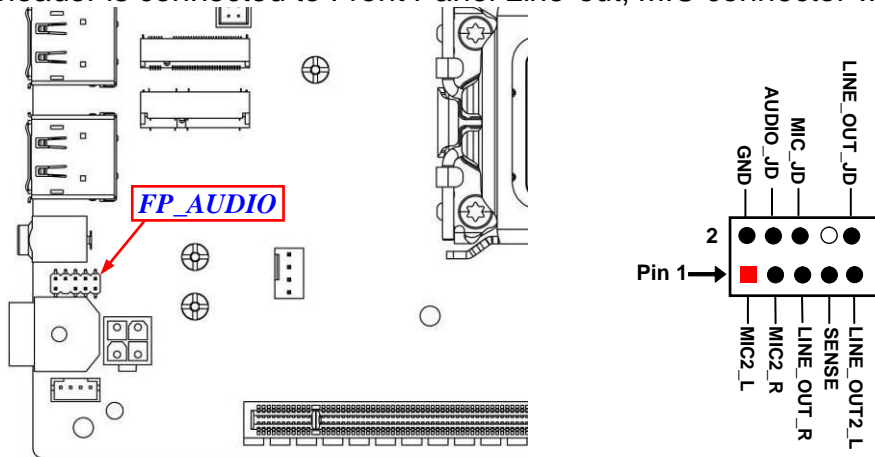

SPEAK_CON (4-pin): 3W 8 Ω Amplifier Wafer

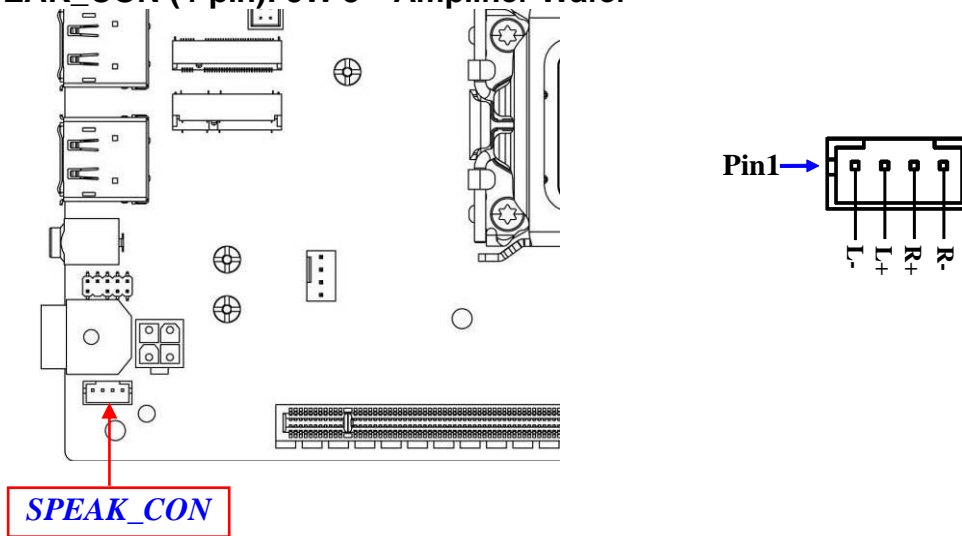

COM1/2/3/4/5/6(9-pin): Serial Port Headers

***COM1/2:** RS232/422/485 Serial Port Header.

COM3/4/5/6: RS232 Serial Port Header.

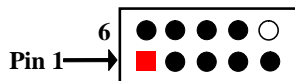
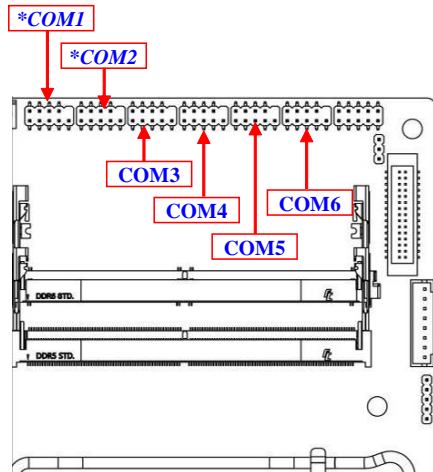

Pin NO.	RS232	*RS422 <i>(optional)</i>	*RS485 <i>(optional)</i>
Pin 1	DCD -	TX-	DATA-
Pin 2	SIN -	TX+	DATA+
Pin 3	SOUT -	RX+	NC
Pin 4	DTR -	RX-	NC
Pin 5	GND	GND	GND
Pin 6	DSR -	NC	NC
Pin 7	RTS -	NC	NC
Pin 8	CTS -	NC	NC
Pin 9	RI -	NC	NC

***Note:** COM1 & COM2 header can function as RS232/422/485 port header. In normal settings COM1 & COM2 function as RS232 header. With compatible COM cable COM1 & COM2 can function as RS422 or RS 485 header. User also needs to go to BIOS to set 'Transmission Mode Select' (refer to [Page-36/37](#)) at first, before using specialized cable to connect different pins of this port.

FP_USB1/*FP_USB2 (9-pin): USB 2.0 Port Header

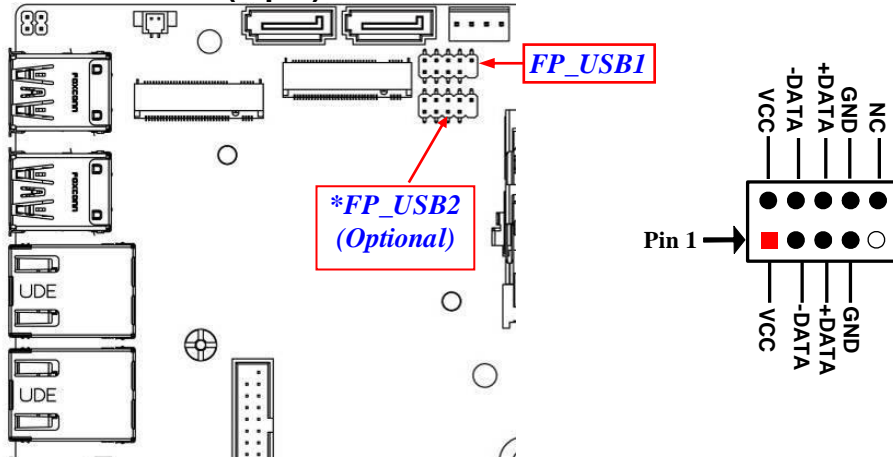

***Note:**FP_USB2 is only optional to MI215Q6700/R6800 series.

***FP_USB3 (19-pin): USB 3.2(Gen.1) Port Header**

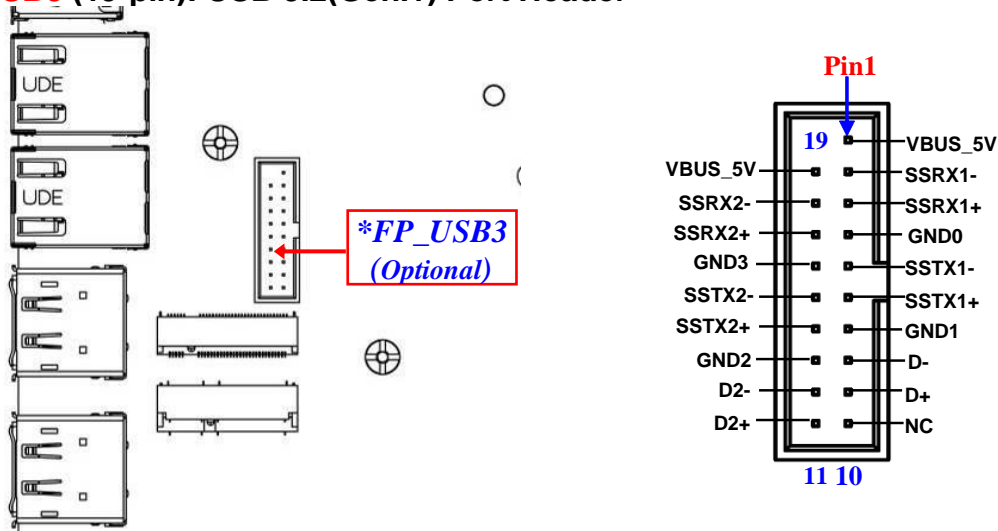

***Note:**FP_USB3 is only optional to MI215Q6700/R6800 series.

GPIO (10-pin): 8-bit GPIO/80 Port Header

JP4 Open: For 80Port Function;

JP4 Closed: Normal 8-bit GPIO.

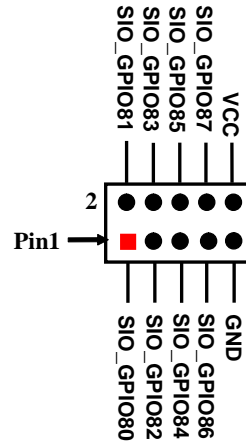
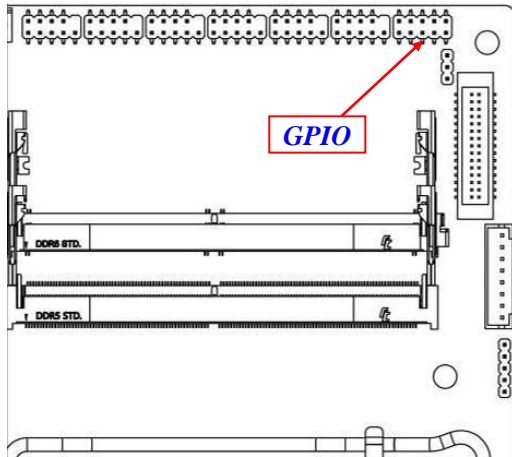

**Note: GPIO can function as Debug display port or GPIO port via JP4 jumper setting (refer to Page-13 for JP4 description).*

SMBUS1 (5-Pin): SMBUS Header

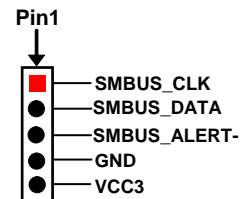
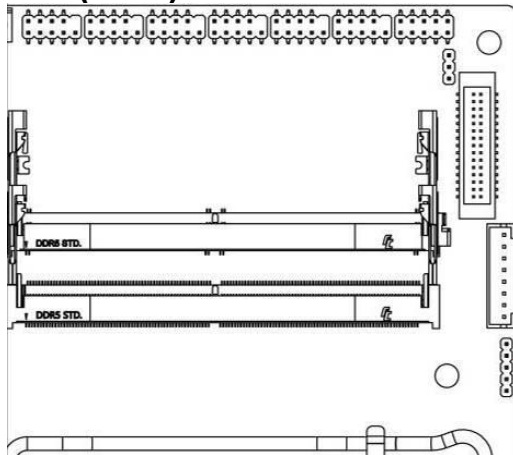

LVDS_EDP (30-Pin): LVDS/EDP LCD Panel Wafer

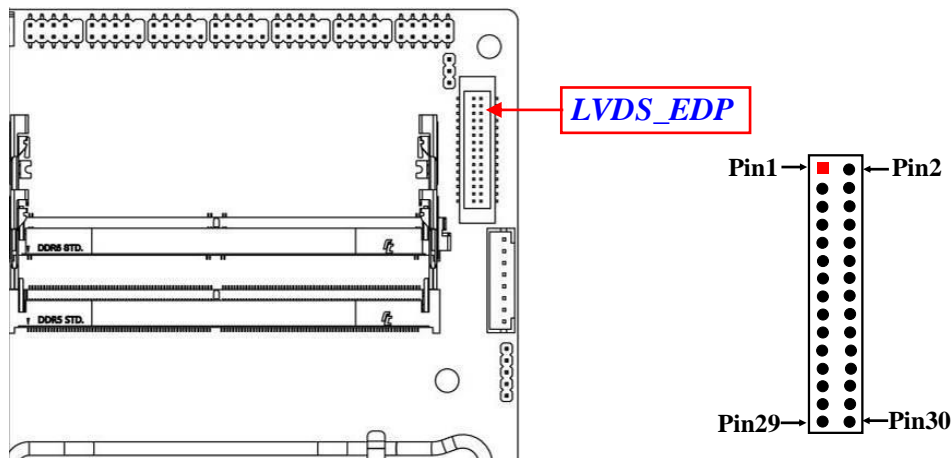

Pin Define	Pin NO.	Pin NO.	Pin Define
LVDSB_DATAN3	Pin 1	Pin 2	LVDSB_DATAP3
LVDSB_CLKN	Pin 3	Pin 4	LVDSB_CLKP
LVDSB_DATAN2	Pin 5	Pin 6	LVDSB_DATAP2
LVDSB_DATAN1	Pin 7	Pin 8	LVDSB_DATAP1
LVDSB_DATAN0	Pin 9	Pin 10	LVDSB_DATAP0
LVDS_DDC_SDA	Pin 11	Pin 12	LVDS_DDC_SCL
GND	Pin 13	Pin 14	GND
GND	Pin 15	Pin 16	GND
LVDSA_DATAP3	Pin 17	Pin 18	LVDSA_DATAN3
LVDSA_CLKP/eDP_AUXP	Pin 19	Pin 20	LVDSA_CLKN/eDP_AUXN
LVDSA_DATAP2/eDP_TX0P	Pin 21	Pin 22	LVDSA_DATAN2/eDP_TX0N
LVDSA_DATAP1/eDP_TX1P	Pin 23	Pin 24	LVDSA_DATAN1/eDP_TX1N
LVDSA_DATAP0	Pin 25	Pin 26	LVDSA_DATAN0
LCD_VCC	Pin 27	Pin 28	LCD_VCC
LCD_VCC	Pin 29	Pin 30	LCD_VCC

***Note:** 1. Maximum current limit is **2A** while using **5V/12V** backlight power working voltage (refer to **Page-12 JP5 settings**); 2. Maximum current limit is **2A** while using **3.3V/5V/12V LCD_VCC** working voltage (refer to **Page-11 JP3 settings**).

****Warning!** Wrong voltage setting will result in screen burn out.

INVERTER1 (8-pin): LVDS/eDP Inverter Connector

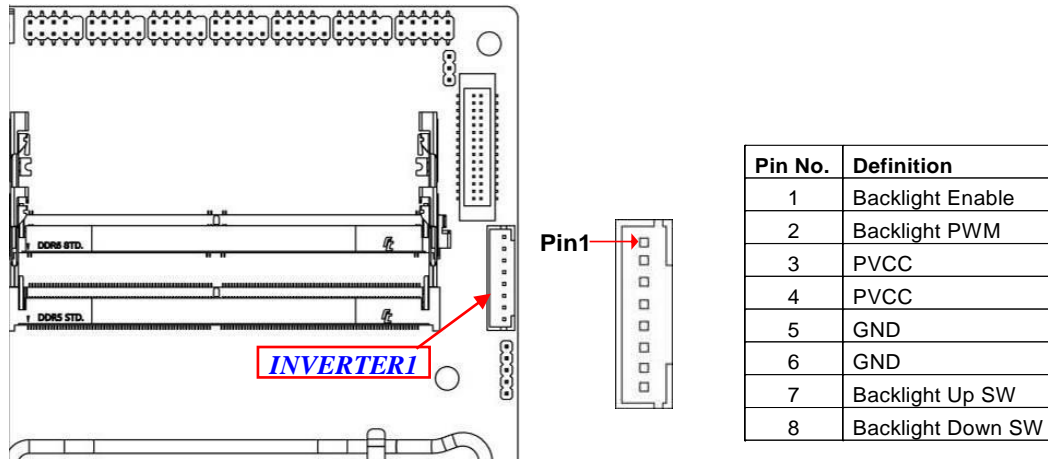

Warning! Find Pin-1 location of the inverter and make sure that the installation direction is correct! Otherwise serious harm will occur to the board/display panel!!

2-3 Maximum Voltage & Current Limit

Below is a list of maximum voltage & Current Limit specification for motherboard interface (including but not limited to slots, connectors and headers) for setup reference:

Parts	Working Voltage	Current Support
USB Ports from	USB1	5V 2A
	USB2	5V 2A
	FP_USB1	5V 1.5A
	*FP_USB2	5V 1.5A
	*FP_USB3	5V 1.5A
FP	5V	1A
GPIO	5V	1A
SMBUS1	5V	0.5A
LVDS_EDP(JP3)	3.3V/5V/12V(via jumper setting)	2A
INVERTER1 (JP5)	5V/12V(via jumper setting)	2A
CPUFAN1	12V	1.5A

***Note:**FP_USB2 & FP_USB3 is only optional to MI215Q6700/R6800 series.

Chapter 3

Introducing BIOS

Notice! The BIOS options in this manual are for reference only. Different configurations may lead to difference in BIOS screen and BIOS screens in manuals are usually the first BIOS version when the board is released and may be different from your purchased motherboard. Users are welcome to download the latest BIOS version form our official website.

The BIOS is a program located on a Flash Memory on the motherboard. This program is a bridge between motherboard and operating system. When you start the computer, the BIOS program will gain control. The BIOS first operates an auto-diagnostic test called POST (power on self test) for all the necessary hardware, it detects the entire hardware device and configures the parameters of the hardware synchronization. Only when these tasks are completed done it gives up control of the computer to operating system (OS). Since the BIOS is the only channel for hardware and software to communicate, it is the key factor for system stability, and in ensuring that your system performance as its best.

3-1 Entering Setup

Power on the computer and by pressing immediately allows you to enter Setup. If the message disappears before your respond and you still wish to enter Setup, restart the system to try again by turning it OFF then ON or pressing the “RESET” button on the system case. You may also restart by simultaneously pressing <Ctrl>, <Alt> and <Delete> keys. If you do not press the keys at the correct time and the system does not boot, an error message will be displayed and you will again be asked to

Press **** to enter Setup

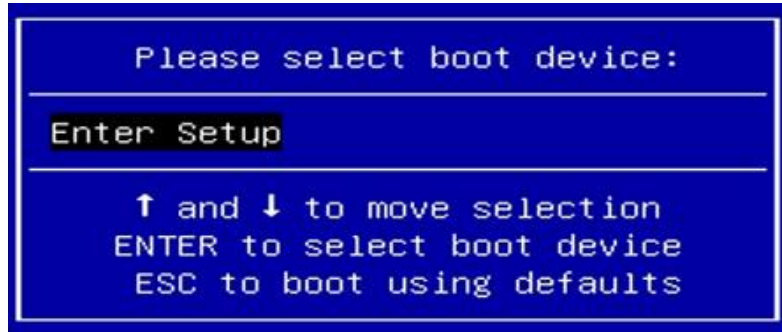

3-2 BIOS Menu Screen

The following diagram show a general BIOS menu screen:

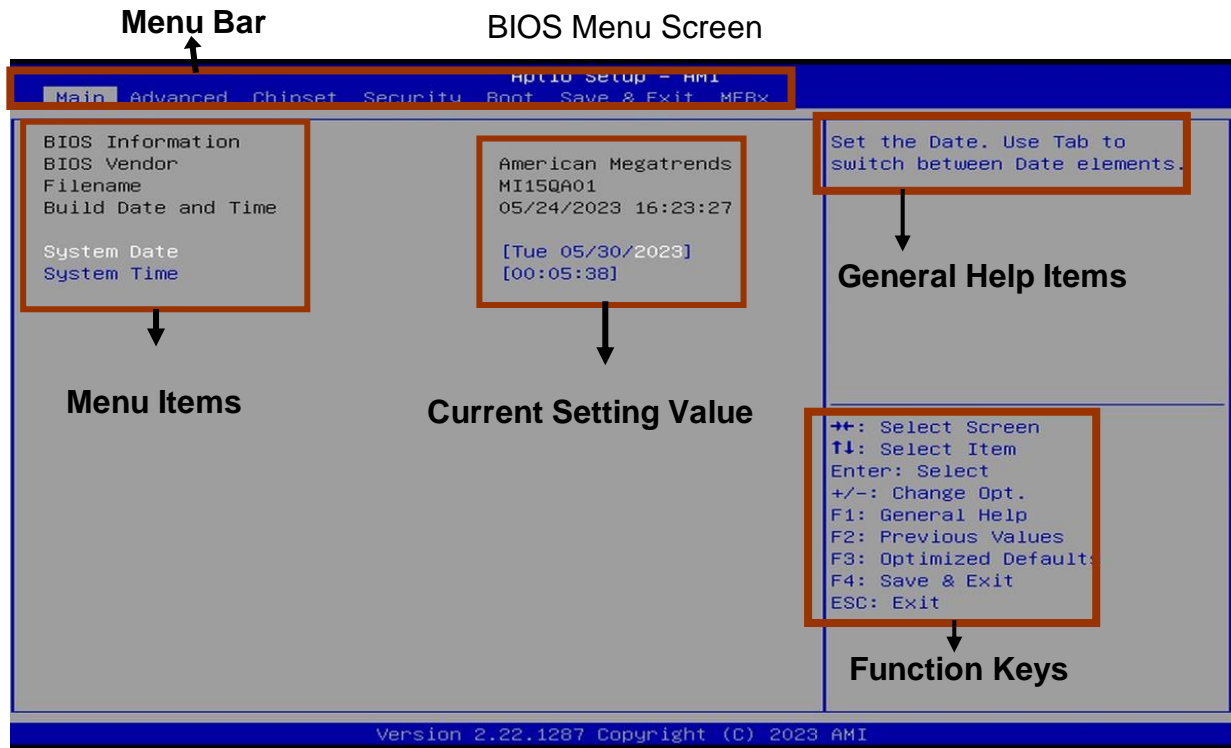

3-3 Function Keys

In the above BIOS Setup main menu of, you can see several options. We will explain these options step by step in the following pages of this chapter, but let us first see a short description of the function keys you may use here:

- Press ←→ (left, right) to select screen;
- Press ↑↓ (up, down) to choose, in the main menu, the option you want to confirm or to modify.
- Press <Enter> to select.
- Press <+>/<-> keys when you want to modify the BIOS parameters for the active option.
- [F1]: General help.
- [F2]: Previous value.
- [F3]: Optimized defaults.
- [F4]: Save & Reset.
- Press <Esc> to quit the BIOS Setup.

3-4 Getting Help

Main Menu

The on-line description of the highlighted setup function is displayed at the top right corner the screen.

Status Page Setup Menu/Option Page Setup Menu

Press [F1] to pop up a small help window that describes the appropriate keys to use and the possible selections for the highlighted item. To exit the Help Window, press <Esc>.

3-5 Menu Bars

There are six menu bars on top of BIOS screen:

Main	To change system basic configuration
Advanced	To change system advanced configuration
Chipset	To change chipset configuration
Security	Password settings
Boot	To change boot settings
Save & Exit	Save setting, loading and exit options.

User can press the right or left arrow key on the keyboard to switch from menu bar. The selected one is highlighted.

3-6 Main Menu

Main menu screen includes some basic system information. Highlight the item and then use the <+> or <-> and numerical keyboard keys to select the value you want in each item.



System Date

Set the date. Please use [Tab] to switch between date elements.

System Time

Set the time. Please use [Tab] to switch between time elements.

3-7 Advanced Menu

BIOS screen from M1215 series with Q6700 and R6800 chipset:

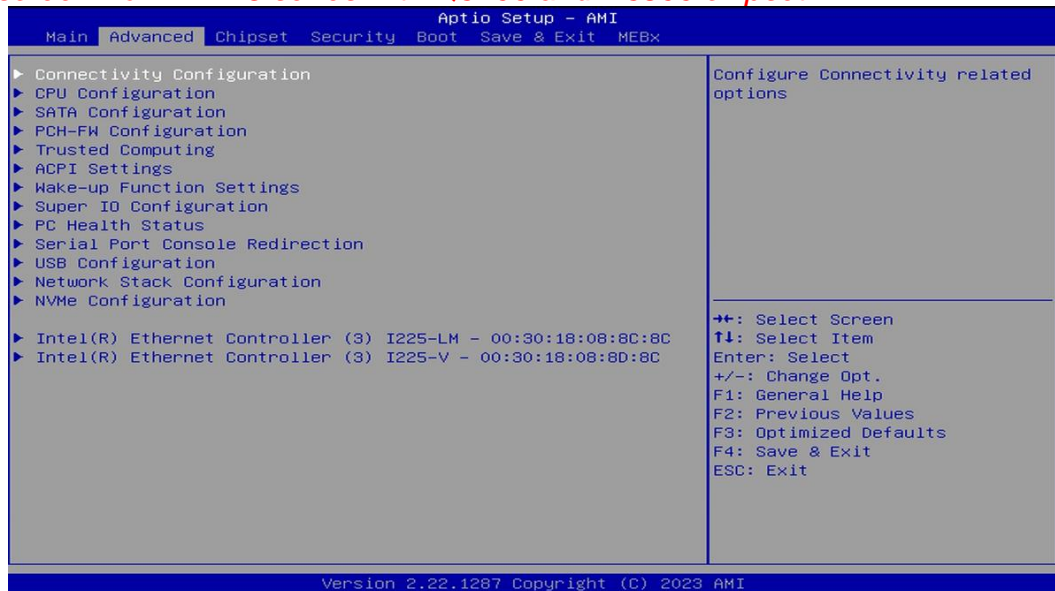

BIOS screen from MI215 series with H6100 chipset:

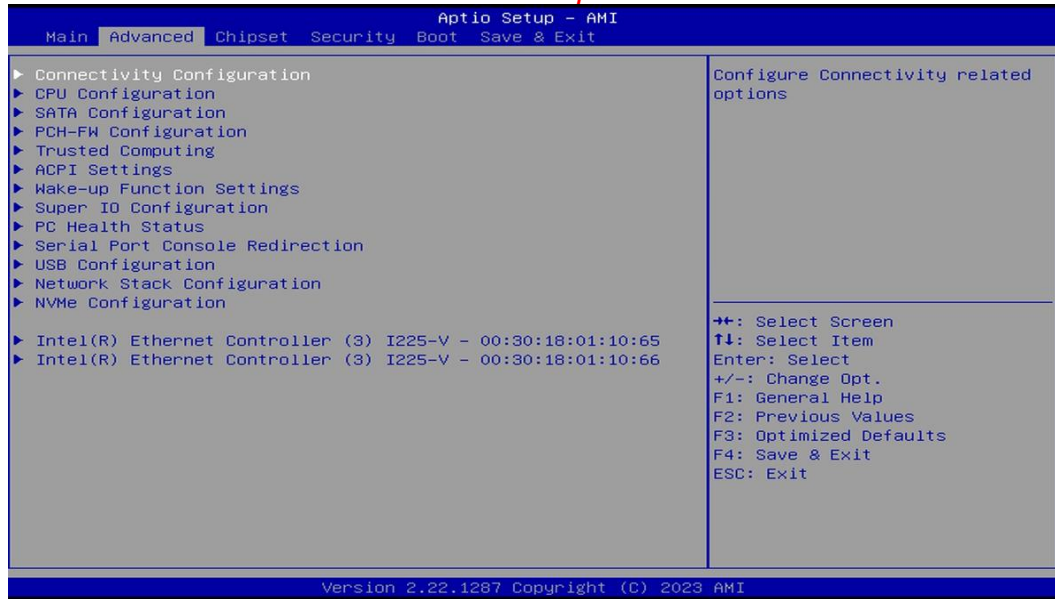

▶ **Connectivity Configuration**

Press [Enter] to make settings for the following sub-item:

CNVi Mode

This option configures connectivity.

[Auto Detection] means that if Discrete solution is discovered it will be enabled by default. Otherwise integrated solution (CNVi) will be enabled ;

[Disable Integrated] disables Integrated solution

The optional settings are: [Disable Integrated]; [Auto Detection]

▶ **CPU Configuration**

Press [Enter] to view current CPU configuration and make settings for the following sub-items:

Hyper-Threading

Use this item to enable or disable Hyper-Threading Technology

The optional settings: [Disabled]; [Enabled].

Intel (VMX) Virtualization Technology

When enabled, a VHM can utilize the additional hardware capabilities provided by Vanderpool Technology.

The optional settings: [Disabled]; [Enabled].

Intel (R) SpeedStep™

Use this item to Allows more than two frequency ranges to be supported.

The optional settings: [Disabled]; [Enabled].

C states

Use this item to enable/disable CPU Power management. Allows CPU to go to C states when it's not 100% utilized.

The optional settings: [Disabled]; [Enabled].

Turbo Mode

Use this item to enable/disable processor turbo mode (requires EMTTM enabled too). AUTO means enabled.

The optional settings: [Disabled]; [Enabled].

****Note: Default mode is [Disabled].***

▶ **SATA Configuration**

Press [Enter] to make settings for the following sub-items:

SATA Controller(s)

The optional settings are: [Enabled]; [Disabled].

When set as [Enabled], the following sub-items shall appear:

M.2 (M2M2)

****Note: optional MI215 series with Q6700 and R6800 chipset***

M.2 (M2M1)

****Note: optional MI215 series with H6100 chipset***

Port

Use this item to enable or disable SATA Port

The optional settings are: [Enabled]; [Disabled].

SATA1/2/M.2(M2M1)

****Note: optional MI215 series with Q6700 and R6800 chipset***

SATA1/SATA2

****Note: optional MI215 series with H6100 chipset***

Port

Use this item to enable or disable SATA Port

The optional settings are: [Enabled]; [Disabled].

Hot Plug

Use this item to designates this port as Hot Pluggable.

The optional settings are: [Enabled]; [Disabled].

▶ **PCH-FW Configuration**

Use this item to configure Management engine technology parameters

Press [Enter] to make settings for the following sub-items:

TPM Device Selection

Use this item to selects TPM device: PTT or dTPM. PTT- Enables PTT in SkuMgr
dTPM 1.2 – Disables PTT in SkuMgr Warning! PTT/dTPM will be disabled and all
data saved on it will be lost

The optional settings are: [dTPM]; [PTT].

▶ **Firmware Update Configuration**

Use this item to configure management engine technology parameters.

Me FW Image Re-Flash

Use this item to enable/disable Me FW Image Re-Flash function

The optional settings: [Disabled]; [Enabled]

▶ **Trusted Computing**

Press [Enter] to view ME information and make settings in the following sub-items:

Security Device Support

Use this item to enables or disables BIOS support for security device. O.S will not
Show security device. TCG EFI protocol and INT1A interface will not be available.

The optional settings: [Disabled]; [Enabled].

When set as [Enabled], user can make settings in the following items that appear:

Pending operation

Use this item to schedule an operation for the security device. NOTE: Your computer
will reboot during restart in order to change state of security device

The optional settings: [None]; [TPM Clear].

TPM Device Selection

Use this item to selects TPM device: PTT or dTPM. PTT-Enables PTT in SkuMgr
dTPM 1.2 – Disables PTT in SkuMgr Warning! PTT/dTPM will be disabled and all
data saved on it will be lost

The optional settings: [dTPM]; [PTT].

▶ **ACPI Settings**

Press [Enter] to make settings for the following sub-items:

ACPI Settings

ACPI Sleep State

Use this item to select the highest ACPI sleep state the system will enter when the suspend button is pressed.

The optional settings are: [Suspend Disabled]; [S3 (Suspend to RAM)].

▶ **Wake-up Function Settings**

Wake-up System With Fixed Time

Use this item to enable or disable system wake on alarm event. When enabled, system will wake on the hr: min: sec specified

The optional settings: [Disabled]; [Enabled].

When set as [Enabled], user can make settings in the following items that appear:

Wake-up Hour

Use this item to select 0-23 for example enter 3 for 3am and 15 for 3pm

Wake-up Minute

Use this item to select 0-59

Wake-up Second

Use this item to select 0-59

Wake-up System with Dynamic Time

**This item will only show when 'Wake-up System With Fixed Time' is set as [Disabled].*

Use this item to enable or disable system wake on alarm event. When enabled, system will wake on the current time + Increase minute(s)

When set as [Enabled], user can make settings in the following items that appear:

Wake-up Minute Increase

Use this item to select 1-60

PCIE Wake-up from S3-S5

The optional settings: [Disabled]; [Enabled].

USB S3/S4 Wake-up

Use this item to enable or disable USB S3/S4 Wake-up Support only disable ERP function

The optional settings: [Disabled]; [Enabled].

USB S5 Power

Use this item to USB Power after system shutdown support only disable ERP function
The optional settings: [Disabled]; [Enabled].

▶ **Super IO Configuration**

Press [Enter] to make settings for the following sub-items:

Super IO Configuration

ERP Support

Use this item to energy-related products function. Disable ERP to active all wake-up functions.

The optional settings: [Disabled]; [Auto].

▶ **Serial Port 1 Configuration**

Press [Enter] to make settings for the following items:

Serial Port

Use this item to enable or disable serial port (COM).

The optional settings: [Disabled]; [Enabled].

Change Settings

Use this item to select an optimal setting for super IO device.

The optional settings are: [IO=3F8h; IRQ=4]; [IO=3F8h; IRQ=3,4,5,7,10,11];

[IO=2F8h; IRQ=3,4,5,7,10,11]; [IO=3E8h; IRQ=3,4,5,7,10,11]; [IO=2E8h;

IRQ=3,4,5,7,10,11];

Transmission Mode Select

The optional settings are: [RS422]; [RS232]; [RS485]

Mode Speed Select

Use this item to RS232/RS422/RS485 Speed Select

The optional settings: [RS232/RS422/RS485=250Kbps]; [RS232=1Mbps,

RS422/RS485=10Mbps].

▶ **Serial Port 2 Configuration**

Press [Enter] to make settings for the following items:

Serial Port

Use this item to enable or disable serial port (COM).

The optional settings: [Disabled]; [Enabled].

Change Settings

Use this item to select an optimal setting for super IO device.

The optional settings are: [IO=2F8h; IRQ=3]; [IO=3F8h; IRQ=3,4,5,7,10,11]; [IO=2F8h; IRQ=3,4,5,7,10,11]; [IO=3E8h; IRQ=3,4,5,7,10,11]; [IO=2E8h; IRQ=3,4,5,7,10,11];

Transmission Mode Select

The optional settings are: [RS422]; [RS232]; [RS485]

Mode Speed Select

Use this item to RS232/RS422/RS485 Speed Select

The optional settings: [RS232/RS422/RS485=250Kbps]; [RS232=1Mbps, RS422/RS485=10Mbps].

▶ **Serial Port 3 Configuration**

Press [Enter] to make settings for the following items:

Serial Port

Use this item to enable or disable serial port (COM).

The optional settings: [Disabled]; [Enabled].

Change Settings

Use this item to select an optimal setting for super IO device.

The optional settings are: [IO=3E8h; IRQ=10]; [IO=3F8h; IRQ=3,4,5,7,10,11]; [IO=2F8h; IRQ=3,4,5,7,10,11]; [IO=3E8h; IRQ=3,4,5,7,10,11]; [IO=2E8h; IRQ=3,4,5,7,10,11]; [IO=3E0h; IRQ=3,4,5,7,10,11]; [IO=2E0h; IRQ=3,4,5,7,10,11];

▶ **Serial Port 4 Configuration**

Press [Enter] to make settings for the following items:

Serial Port

Use this item to enable or disable serial port (COM).

The optional settings: [Disabled]; [Enabled].

Change Settings

Use this item to select an optimal setting for super IO device.

The optional settings are: [IO=2E8h; IRQ=10]; [IO=3F8h; IRQ=3,4,5,7,10,11]; [IO=2F8h; IRQ=3,4,5,7,10,11]; [IO=3E8h; IRQ=3,4,5,7,10,11]; [IO=2E8h; IRQ=3,4,5,7,10,11]; [IO=3E0h; IRQ=3,4,5,7,10,11]; [IO=2E0h; IRQ=3,4,5,7,10,11];

▶ **Serial Port 5 Configuration**

Press [Enter] to make settings for the following items:

Serial Port

Use this item to enable or disable serial port (COM).

The optional settings: [Disabled]; [Enabled].

Change Settings

Use this item to select an optimal setting for super IO device.

The optional settings are: [IO=3E0h; IRQ=11]; [IO=3F8h; IRQ=3,4,5,7,10,11];

[IO=2F8h; IRQ=3,4,5,7,10,11]; [IO=3E8h; IRQ=3,4,5,7,10,11]; [IO=2E8h;

IRQ=3,4,5,7,10,11]; [IO=3E0h; IRQ=3,4,5,7,10,11]; [IO=2E0h; IRQ=3,4,5,7,10,11];

▶ **Serial Port 6 Configuration**

Press [Enter] to make settings for the following items:

Serial Port

Use this item to enable or disable serial port (COM).

The optional settings: [Disabled]; [Enabled].

Change Settings

Use this item to select an optimal setting for super IO device.

The optional settings are: [IO=2E0h; IRQ=11]; [IO=3F8h; IRQ=3,4,5,7,10,11];

[IO=2F8h; IRQ=3,4,5,7,10,11]; [IO=3E8h; IRQ=3,4,5,7,10,11]; [IO=2E8h;

IRQ=3,4,5,7,10,11]; [IO=3E0h; IRQ=3,4,5,7,10,11]; [IO=2E0h; IRQ=3,4,5,7,10,11];

WatchDog Reset Timer

Use this item to support WDT reset function.

The optional settings: [Disabled]; [Enabled].

When set as [Enabled], the following sub-items shall appear:

WatchDog Reset Timer Value

User can set a value in the range of [4] to [255].

WatchDog Reset Timer Unit

The optional settings are: [Sec.]; [Min.]

ATX Power Emulate AT Power

This item support Emulate AT power function, MB power On/Off control by power supply. Use needs to select 'AT or ATX Mode' on MB jumper at first (refer to JAT_ATX jumper setting Pin 1&2 of for ATX Mode & Pin 2&3 of AT Mode Select).

Case Open Detect

Use this item to detect case has already open or not, show message in POST.

The optional settings: [Disabled]; [Enabled].

When set as [Enabled], system will detect if COPEN has been short or not (*refer to **COPEN** jumper setting for Case Open Detection*); if Pin 1&2 of **COPEN** are short, system will show Case Open Message during POST.

▶ **PC Health Status**

Press [Enter] to view current hardware health status, make further settings in '**SmartFAN Configuration**' and set value in '**Shutdown Temperature**'.

▶ **SmartFAN Configuration**

Press [Enter] to make settings for SmartFAN Configuration:

SmartFAN Configuration

CPUFAN Smart Mode

The optional settings: [Disabled]; [Enabled].

When set as [Enabled], the following sub-items shall appear:

CPUFAN Full-Speed Temperature

Use this item to set CPUFAN full speed temperature. Fan will run at full speed when above this pre-set temperature.

CPUFAN Full-Speed Duty

Use this item to set CPUFAN full-speed duty. Fan will run at full speed when above this pre-set duty.

CPUFAN Idle-Speed Temperature

Use this item to set CPUFAN idle speed temperature. Fan will run at idle speed when below this pre-set temperature.

CPUFAN Idle-Speed Duty

Use this item to set CPUFAN idle speed duty. Fan will run at idle speed when below this pre-set duty.

▶ **Serial Port Console Redirection**

Press [Enter] to make settings for the following sub-items:

COM1

Console Redirection

Use this item to Console Redirection enable or disable.

The optional settings: [Disabled]; [Enabled].

When set as [Enabled], user can make further settings in the '**Console Redirection**'

Settings' screen:

▶ **Console Redirection Settings**

The settings specify how the host computer and the remote computer (which the user is using) will exchange data. Both computers should have the same or compatible settings.

Press [Enter] to make settings for the following sub-items:

Terminal Type

The optional settings: [VT100]; [VT100Plus]; [VT-UTF8]; [ANSI].

[ANSI]: Extended ASCII char set;

[VT100]: ASCII char set;

[VT100Plus]: Extends VT100 to support color, function keys, etc.;

[VT-UTF8]: Uses UTF8 encoding to map Unicode chars onto 1 or more bytes.

Bits per second

Use this item to select serial port transmission speed. The speed must be matched on the other side. Long or noisy lines may require lower speeds.

The optional settings: [9600]; [19200]; [38400]; [57600]; [115200].

Data Bits

The optional settings: [7]; [8].

Parity

A parity bit can be sent with the data bits to detect some transmission errors.

The optional settings: [None]; [Even]; [Odd]; [Mark]; [Space].

[Even]: parity bit is 0 if the num of 1's in the data bits is even;

[Odd]: parity bit is 0 if num of 1's in the data bits is odd;

[Mark]: parity bit is always 1;

[Space]: parity bit is always 0;

[Mark] and **[Space]:** parity do not allow for error detection.

Stop Bits

Stop bits indicate the end of a serial data packet. (A start bit indicates the beginning). The standard setting is 1 stop bit. Communication with slow devices may require more than 1 stop bit.

The optional settings: [1]; [2].

Flow Control

Flow control can prevent data loss from buffer overflow. When sending data, if the receiving buffers are full, a “stop” signal can be sent to stop the data flow. Once the buffers are empty, a “start” signal can be sent to re-start the flow. Hardware flow control uses two wires to send start/stop signals.

The optional settings: [None]; [Hardware RTS/CTS].

VT-UTF8 Combo Key Support

Use this item to enable VT-UTF8 Combination Key Support for ANSI/VT100 terminals.

The optional settings: [Disabled]; [Enabled].

Recorder Mode

With this mode enable only text will be sent. This is to capture Terminal data.

The optional settings: [Disabled]; [Enabled].

Resolution 100x31

Use this item to enable or disable extended terminal resolution.

The optional settings: [Disabled]; [Enabled].

Putty KeyPad

Use this item to select Function Key and KeyPad on Putty.

The optional settings: [VT100]; [LINUX]; [XTERMR6]; [SCO]; [ESCN]; [VT400].

▶ **Legacy Console Redirection Settings**

Press [Enter] to make settings for the following items:

Redirection COM Port

Use this item to select a COM port to display redirection of Legacy OS and Legacy OPROM Messages

The optional settings: [COM1]

Resolution

Use this item to on legacy OS, the number of rows and columns supported redirection

The optional settings: [80x24]; [80x25]

Redirect After POST

When bootloader is selected, then legacy console redirection is disabled before booting to legacy OS. When always enable is selected, the legacy console redirection is enabled for legacy OS. Default setting for this option is set to always

enable.

The optional settings: [Always Enable]; [BootLoader]

**Serial Port for Out-of-Band Management/
Windows Emergency Management Services (EMS)**

Console Redirection EMS

The optional settings: [Disabled]; [Enabled].

When set as **[Enabled]**, user can make further settings in ‘**Console Redirection Settings**’ screen:

▶ **Console Redirection Settings**

The settings specify how the host computer and the remote computer (which the user is using) will exchange data. Both computers should have the same or compatible settings.

Press [Enter] to make settings for the following sub-items.

Terminal Type EMS

The optional settings: [VT100]; [VT100Plus]; [VT-UTF8]; [ANSI].

[VT-UTF8] is the preferred terminal type for out-of-band management. The next best choice is **[VT100+]** and then **[VT100]**. See above, in Console Redirection Settings page, for more help with Terminal Type/Emulation.

Bits per second EMS

Use this item to select serial port transmission speed. The speed must be matched on the other side. Long or noisy lines may require lower speeds.

The optional settings: [9600]; [19200]; [57600]; [115200].

Flow Control

Flow control can prevent data loss from buffer overflow. When sending data, if the receiving buffers are full, a “stop” signal can be sent to stop the data flow. Once the buffers are empty, a “start” signal can be sent to re-start the flow. Hardware flow control uses two wires to send start/stop signals.

The optional settings: [None]; [Hardware RTS/CTS]; [Software Xon/Xoff].

Data Bits EMS

The default setting is: [8].

**This item may or may not show up, depending on different configuration.*

Parity EMS

The default setting is: [None].

**This item may or may not show up, depending on different configuration.*

Stop Bits EMS

The default setting is: [1].

**This item may or may not show up, depending on different configuration.*

▶ **USB Configuration**

Press [Enter] to make settings for the following sub-items:

USB Configuration

XHCI Hand-off

This is a workaround for OSES without XHCI hand-off support. The XHCI ownership change should be claimed by XHCI driver.

The optional settings: [Enabled]; [Disabled].

USB Mass Storage Driver Support

Use this item to enable or disable USB Mass storage driver support

The optional settings: [Disabled]; [Enabled].

USB hardware delay and time-out

USB Transfer time-out

Use this item to set the time-out value for control, bulk, and interrupt transfers.

The optional settings: [1 sec]; [5 sec]; [10 sec]; [20 sec].

Device reset time-out

Use this item to set USB mass storage device start unit command time-out.

The optional settings: [10 sec]; [20 sec]; [30 sec]; [40 sec].

Device power-up delay

Use this item to set maximum time the device will take before it properly reports itself to the host controller. 'Auto' uses default value: for a root port it is 100 ms, for a hub port the delay is taken from hub descriptor.

The optional settings: [Auto]; [Manual].

Select [**Manual**] you can set value for the following sub-item: '**Device power-up delay in seconds**', the delay range in from 1 to 40 seconds, in one second increments.

▶ **Network Stack Configuration**

Press [Enter] to go to '**Network Stack**' screen to make further settings.

Network Stack

Use this item to enable or disable UEFI Network Stack.

The optional settings: [Disabled]; [Enabled].

When set as **[Enabled]**, the following sub-items shall appear:

IPv4 PXE Support

Use this item to enable IPv4 PXE Boot Support. When set as [Disabled], IPv4 PXE boot option will not be created.

The optional settings: [Disabled]; [Enabled].

IPv6 PXE Support

Use this item to enable IPv6 PXE Boot Support. When set as [Disabled], IPv6 PXE boot option will not be created.

The optional settings: [Disabled]; [Enabled].

PXE boot wait time

Use this item to set wait time to press [ESC] key to abort the PXE boot.

Media detect count

Use this item to set number of times presence of media will be checked.

▶ **NVMe Configuration**

Use this item to NVMe Device options settings

▶ **Intel(R) Ethernet Controller(3) I225-LM - XX:XX:XX:XX:XX:XX**

This item shows current network brief information.

***Note: optional for MI215 series with Q6700 and R6800 chipset**

▶ **Intel(R) Ethernet Controller(3) I225-V - XX:XX:XX:XX:XX:XX**

This item shows current network brief information.

***Note: optional for MI215 series with H6100 chipset**

▶ **Intel(R) Ethernet Controller(3) I225-V - XX:XX:XX:XX:XX:XX**

This item shows current network brief information.

3-8 Chipset Menu

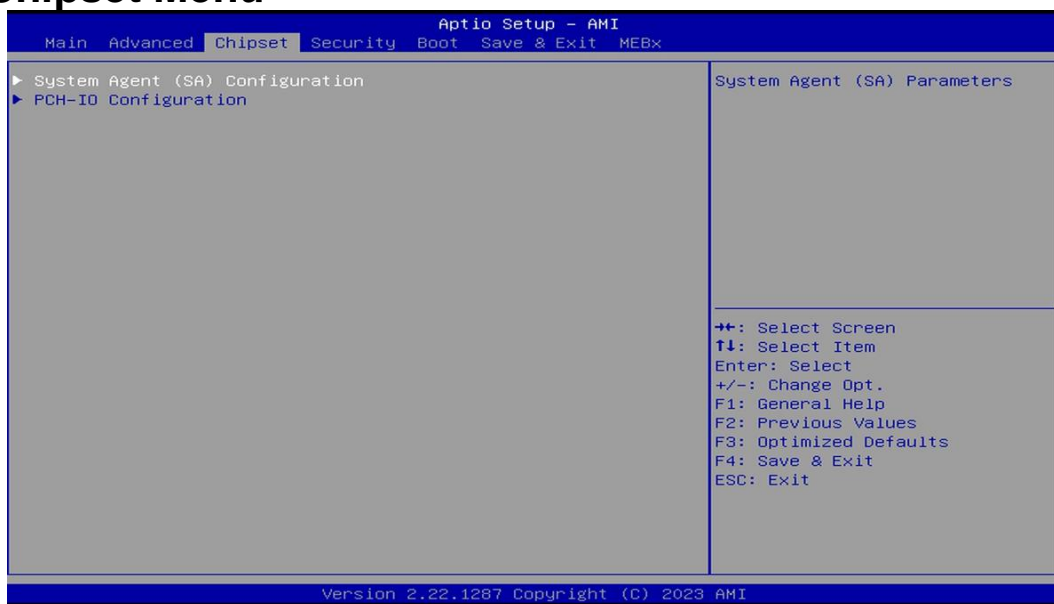

- ▶ **System Agent (SA) Configuration**

Press [Enter] to make settings for the following sub-items:

- ▶ **Memory Configuration**

- ▶ **Maximum Memory Frequency**

Use this item to maximum memory frequency selections in Mhz

The optional settings are: [Auto]; [4000]; [4400]; [4800]; [5000]; [5200]; [5400]; [5600].

- ▶ **Graphics Configuration**

Press [Enter] to make settings for the following sub-items:

- ▶ **PCIe1 Slot**

Use this item to control the PCI Express Root port

The optional settings: [Disabled]; [Enabled]

- ▶ **PCIe Slot Lane Select**

Use this item to select X16 or X8/X8

The optional settings: [X16]; [X8/X8]

***Note: optional for MI215 series with Q6700 and R6800 chipset**

eDP/LVDS

Use this item to select the active configuration.

The optional settings: [Disabled]; [Enabled]

When set as **[Enabled]**, the following sub-items shall appear:

Panel Type

Use this item to panel type

The optional settings: [800*480 18bit Single]; [800*600 18bit Single]; [800*600 24bit Single]; [1024*600 18bit Single]; [1024*768 18bit Single]; [1024*768 24bit Single]; [1280*800 18bit Single]; [1280*800 24bit Single]; [1366*768 18bit Single]; [1366*768 24bit Single]; [1440*900 18bit Dual]; [1440*900 24bit Dual]; [1280*1024 24bit Dual]; [1680*1050 24bit Dual]; [1920*1080 24bit Dual]; [eDP].

Backlight Control

Use this item to back light control setting

The optional settings: [PWM Inverted]; [PWM Normal]

Primary Display

Use this item to select which graphics device should be primary display

The optional settings: [Auto]; [IGFX]; [PEG Slot]; [PCH PCIE]

Internal Graphics

Use this item to keep IGFX enabled based on the setup options.

The optional settings: [Auto]; [Disabled]; [Enabled]

Aperture Size

Use this item to select the aperture size

Note: Above 4GB MMIO BIOS assignment is automatically enabled when selecting 2048MB aperture. To use this feature, please disable CSM Support.

The optional settings: [128MB]; [256MB]; [512MB]; [1024MB]

DVMT Pre-Allocated

Use this item to select DVMT 5.0 Pre-Allocated (Fixed) graphics memory size used by the internal graphics device

The optional settings: [32M]; [64M]; [128M]

DVMT Total Gfx Mem

Use this item to select DVMT 5.0 total graphic memory size used by the internal graphics device

-
- The optional settings: [128M]; [256M]; [Max]
- ▶ **VMD setup menu**

Press [Enter] to make settings for the following sub-items:

 - Enable VMD controller**

Use this item to enable/disable to VMD controller
The optional settings: [Disabled]; [Enabled].
When set as [Enabled], the following sub-items shall appear:
 - Enable VMD Global Mapping**

Use this item to enable/disable to VMD global mapping
The optional settings: [Disabled]; [Enabled].
When set as [Disabled], the following sub-items shall appear:
 - Map this Root Port under VMD**

Use this item to Map/UnMap this root port to VMD
The optional settings: [Disabled]; [Enabled].
 - Root Port BDF details**
- ▶ **PCH-IO Configuration**

Press [Enter] to make settings for the following sub-items:

 - HD Audio**

Use this item to control detection of the HD-Audio device.
Disabled= HAD will be unconditionally disabled
Enabled= HAD will be unconditionally enabled
The optional settings: [Disabled]; [Enabled].
 - Onboard Lan1 Controller**

Use this item to enable or disable onboard NIC.
The optional settings: [Enabled]; [Disabled].
 - Onboard Lan2 Controller**

Use this item to control the PCI Express root port..
The optional settings: [Disabled]; [Enabled].
 - System State after Power Failure**

Use this item to specify what state to go to when power re-applied after a power failure (G3 state).
The optional settings: [Always On]; [Always Off]; [Former State].
-

3-9 Security Menu

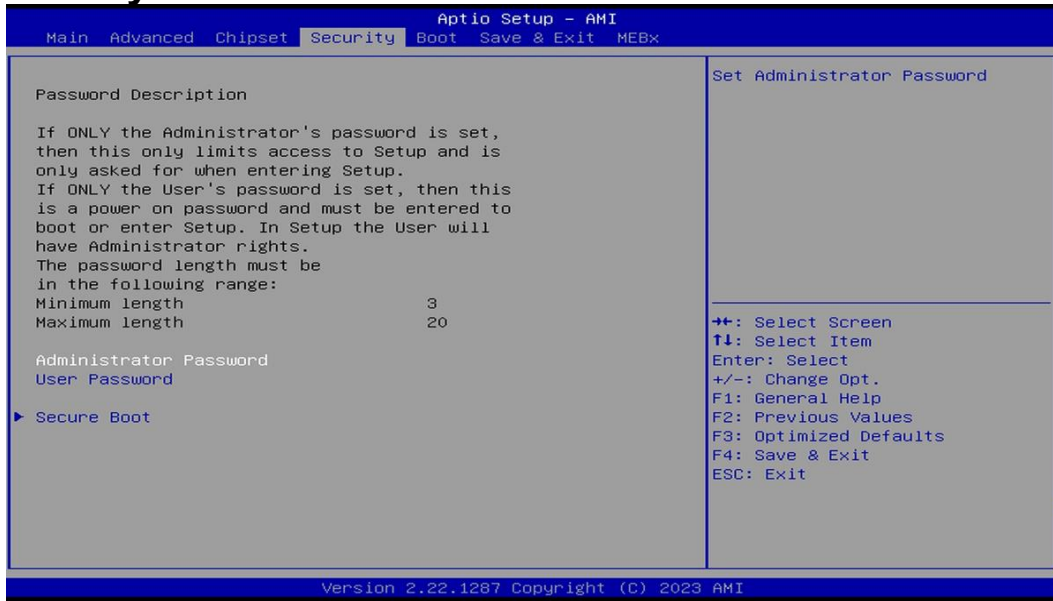

Security menu allow users to change administrator password and user password settings.

Administrator Password

If there is no password present on system, please press [Enter] to create new administrator password. If password is present on system, please press [Enter] to verify old password then to clear/change password. Press again to confirm the new administrator password.

User Password

If there is no password present on system, please press [Enter] to create new user password. If password is present on system, please press [Enter] to verify old password then to clear/change password. Press again to confirm the new user password.

▶ Secure Boot

Press [Enter] to make customized secure settings:

System Mode

Secure Boot

Secure Boot feature is Active if Secure Boot is Enabled, Platform Key(PK) is enrolled and the System is in User mode. The mode change requires platform reset.

The optional settings: [Disabled]; [Enabled].

Secure Boot Mode

Set UEFI Secure Boot Mode to Standard mode or Custom mode. This change is effective after save. After reset, this mode will return to Standard mode.

In Custom mode, Secure Boot Policy variables can be configured by a physically present user without full authentication.

The optional settings: [Standard]; [Custom].

When set as [**Custom**], user can make further settings in the following items that show up:

- ▶ **Restore Factory Keys**

Use this item to force system to User Mode, to install factory default Secure Boot key databases.

- ▶ **Reset To Setup Mode**

Use this item to delete all Secure Boot key databases from NVRAM.

- ▶ **Key Management**

This item enables expert users to modify Secure Boot Policy variables without full authentication, which includes the following items:

- ▶ **Vendor Keys**

- ▶ **Factory Key Provision**

- ▶ This item is for user to install factory default Secure Boot keys after the platform reset and while the System is in Setup mode.

- The optional settings: [Disabled]; [Enabled].

- ▶ **Restore Factory Keys**

- ▶ Use this item to force system into User Mode. Install factory default Secure Boot key databases.

- ▶ **Reset To Setup Mode**

- ▶ Use this item to delete all Secure Boot key databases from NVRAM.

- ▶ **Enroll Efi Image**

- ▶ This item allows the image to run in Secure Boot mode.

- ▶ Enroll SHA256 Hash certificate of a PE image into Authorized Signature Database (db).

▶ **Export Secure Boot variables**

Use this item to copy NVRAM content of Secure Boot variables to files in a root folder on a file system device.

Secure Boot variable/Size/Keys/Key Source

▶ **Platform Key(PK)/Key Exchange Keys/Authorized Signatures/Forbidden Signatures/ Authorized TimeStamps/OsRecovery Signatures**

Use this item to enroll Factory Defaults or load certificates from a file:

1. Public Key Certificate:

- a) EFI_SIGNATURE_LIST
- b) EFI_CERT_X509 (DER)
- c) EFI_CERT_RSA2048 (bin)
- d) EFI_CERT_SHAXXX

2. Authenticated UEFI Variable

3. EFI PE/COFF Image (SHA256)

Key Source: Factory, External, Mixed

3-10 Boot Menu

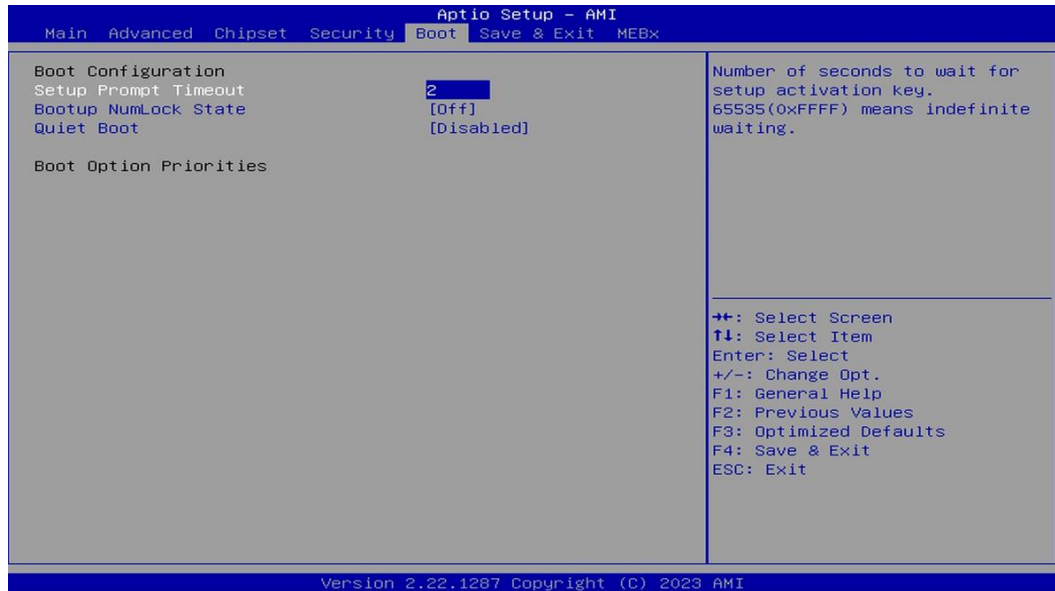

Boot Configuration

▶ Setup Prompt Timeout

Use this item to set number of seconds to wait for setup activation key.
65535(0Xffff) means indefinite waiting

▶ Bootup Numlock State

Use this item to select keyboard numlock state.
The optional settings are: [On]; [Off].

▶ Quiet Boot

The optional settings are: [Disabled]; [Enabled].

When set as [Enabled], user can make settings in the following items that appear:

Boot Option Priorities

3-11 Save & Exit Menu

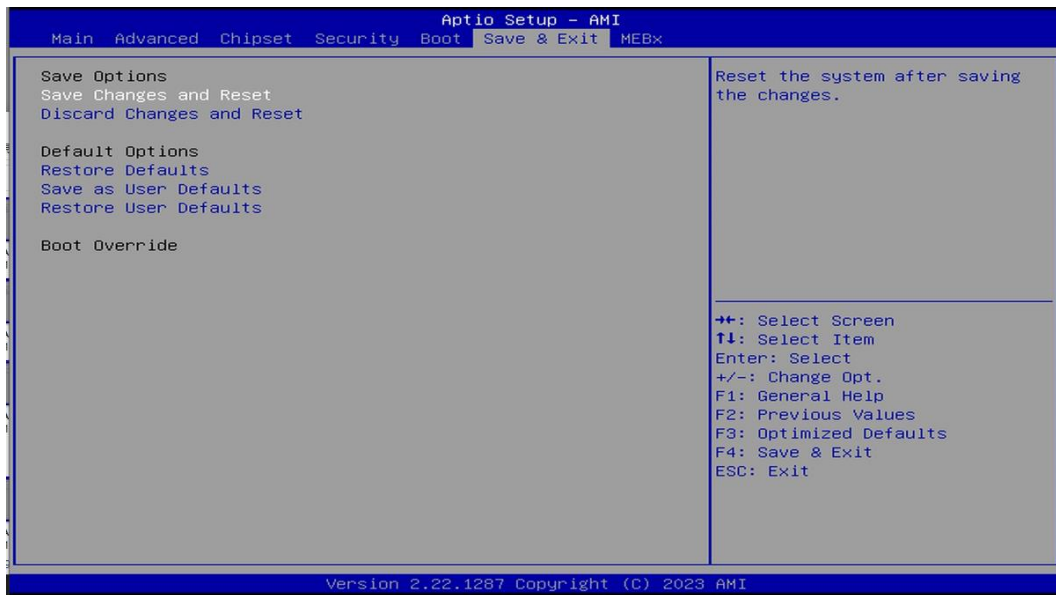

▶ Save Changes and Reset

This item allows user to reset the system after saving the changes.

▶ **Discard Changes and Reset**

This item allows user to reset the system without saving any changes.

▶ **Restore Defaults**

Use this item to restore /load default values for all the setup options.

▶ **Save as User Defaults**

Use this item to save the changes done so far as user defaults.

▶ **Restore User Defaults**

Use this item to restore defaults to all the setup options.

Boot Override

3-12 MEBx

***Note: optional for MI215 series with Q6700 and R6800 chipset**



▶ **Intel(R) ME Password**

Use this item to MEBx Login.