

MP21

User's Manual

NO.: G03-MP21-F

Revision: 1.0

Release date: February 21, 2024

Trademark:

- * Specifications and Information contained in this documentation are furnished for information use only, and are subject to change at any time without notice, and should not be construed as a commitment by manufacturer.

Environmental Protection Announcement

Do not dispose this electronic device into the trash while discarding. To minimize pollution and ensure environment protection of mother earth, please recycle.



TABLE OF CONTENT

ENVIRONMENTAL SAFETY INSTRUCTION	iv
USER'S NOTICE	v
MANUAL REVISION INFORMATION	v
ITEM CHECKLIST	v
CHAPTER 1 INTRODUCTION OF THE MOTHERBOARD	
1-1 FEATURE OF MOTHERBOARD	1
1-2 SPECIFICATION	2
1-3 LAYOUT DIAGRAM	3
CHAPTER 2 HARDWARE INSTALLATION	
2-1 JUMPER SETTINGS	8
2-2 CONNECTORS , HEADERS & WAFERS	13
2-2-1 REAR I/O PANEL CONNECTORS	13
2-2-2 MOTHERBOARD INTERNAL CONNECTORS	14
2-2-3 PIN DEFINITION FOR HEADERS & WAFERS	15
2-2-4 MAXIMUM VOLTAGE & CURRENT LIMIT	19
CHAPTER 3 INTRODUCING BIOS	
3-1 ENTERING SETUP	20
3-2 BIOS MENU SCREEN	21
3-3 FUNCTION KEYS	22
3-4 GETTING HELP	22
3-5 MEMU BARS	22
3-6 MAIN MENU	23
3-7 ADVANCED MENU	24
3-8 CHIPSET MENU	35
3-9 SECURITY MENU	38
3-10 BOOT MENU	41
3-11 SAVE & EXIT MENU	42



Environmental Safety Instruction

- Avoid the dusty, humidity and temperature extremes. Do not place the product in any area where it may become wet.
- 0 to 60 centigrade is the suitable temperature. (The figure comes from the request of the main chipset)
- Generally speaking, dramatic changes in temperature may lead to contact malfunction and crackles due to constant thermal expansion and contraction from the welding spots' that connect components and PCB. Computer should go through an adaptive phase before it boots when it is moved from a cold environment to a warmer one to avoid condensation phenomenon. These water drops attached on PCB or the surface of the components can bring about phenomena as minor as computer instability resulted from corrosion and oxidation from components and PCB or as major as short circuit that can burn the components. Suggest starting the computer until the temperature goes up.
- The increasing temperature of the capacitor may decrease the life of computer. Using the close case may decrease the life of other device because the higher temperature in the inner of the case.
- Attention to the heat sink when you over-clocking. The higher temperature may decrease the life of the device and burned the capacitor.

USER'S NOTICE

COPYRIGHT OF THIS MANUAL BELONGS TO THE MANUFACTURER. NO PART OF THIS MANUAL, INCLUDING THE PRODUCTS AND SOFTWARE DESCRIBED IN IT MAY BE REPRODUCED, TRANSMITTED OR TRANSLATED INTO ANY LANGUAGE IN ANY FORM OR BY ANY MEANS WITHOUT WRITTEN PERMISSION OF THE MANUFACTURER.

THIS MANUAL CONTAINS ALL INFORMATION REQUIRED TO USE THIS MOTHER-BOARD SERIES AND WE DO ASSURE THIS MANUAL MEETS USER'S REQUIREMENT BUT WILL CHANGE, CORRECT ANY TIME WITHOUT NOTICE. MANUFACTURER PROVIDES THIS MANUAL "AS IS" WITHOUT WARRANTY OF ANY KIND, AND WILL NOT BE LIABLE FOR ANY INDIRECT, SPECIAL, INCIDENTAL OR CONSEQUENTIAL DAMAGES (INCLUDING DAMAGES FOR LOSS OF PROFIT, LOSS OF BUSINESS, LOSS OF USE OF DATA, INTERRUPTION OF BUSINESS AND THE LIKE).

PRODUCTS AND CORPORATE NAMES APPEARING IN THIS MANUAL MAY OR MAY NOT BE REGISTERED TRADEMARKS OR COPYRIGHTS OF THEIR RESPECTIVE COMPANIES, AND THEY ARE USED ONLY FOR IDENTIFICATION OR EXPLANATION AND TO THE OWNER'S BENEFIT, WITHOUT INTENT TO INFRINGE.

Manual Revision Information

Reversion	Revision History	Date
1.0	First Edition	2024-2-21

Item Checklist

- Motherboard
- Cable(s)

Chapter 1

Introduction of the Motherboard

1-1 Feature of Motherboard

- Onboard Intel® Atom® x6000E series Processors (TDP 6.5W), with low power consumption and high performance
- Onboard LPDDR4x 3200Hz up to 4GB
- Onboard 2* Realtek GbE LAN ports
- Support 1* HDMI2.0b, 1* LVDS (co-layout eDP)
- Onboard 1* M.2 E-key slot, type-2230 (USB2.0/PCIe Gen.3 x1) supports WIFI/BT Module
- Onboard 1* M.2 B-key slot, type-2242/3042/3052 (SATA/PCIe Gen.3 x1/USB3.1) support 4G/5G module or NVME/SATA for **B/M-key M.2 storage**
- Support 1* USB3.1 (Gen.2) type-A port & 1* USB3.1 (Gen.2) type-C port; 3* USB2.0 type-A ports
- Support 2* COM Ports (support RS232/RS422/RS485)
- Support 12V DC-in
- Support Intel® PTT (Integrated TPM)
- Support onboard eMMC (**Optional**)
- Support Watchdog function
- Solution for Intelligent Home / Digital Signage / IOT

1-2 Specification

Spec	Description
Design	<ul style="list-style-type: none"> PICO-ITX SBC; PCB size: 10x 7.2 cm
Embedded CPU	<ul style="list-style-type: none"> Integrated with Intel® Atom® x6000E series Processors (TDP 6.5W) <i>* Note: CPU model varies from different IPC options. Please consult your dealer for more information of onboard CPU. TDP varies depending on CPU.</i>
Memory Slot	<ul style="list-style-type: none"> Onboard LPDDR4x 3200MHz up to 4GB <i>*Note: For more memory compatibility information please consults your local dealer.</i>
Expansion Slot	<ul style="list-style-type: none"> M2E1:1* M.2 E-key type-2230 (USB2.0/PCIe3.0 x1 interface) supports WIFI/BT Module *M2B1:1* M.2 B-key type-2242/3042/3052 (SATA/PCIe 3.0 x1/ USB3.1 interface) for 4G/5G/LTE Module or NVME/SATA for storage (Only available on compatible B/M-key M.2 storage) *SIMCARD1: 1* Nano SIM card slot <i>*Note: M2B1 co-functions with SIMCARD1.</i>
Storage	<ul style="list-style-type: none"> Onboard 64GB eMMC (Supported by MP21-62104 only)
LAN Chip	<ul style="list-style-type: none"> Integrated with 2* Realtek Gigabit LAN chip Support Fast Ethernet LAN function of providing 10/100/1000Mbps Ethernet data transfer rate
Audio Chip	<ul style="list-style-type: none"> Integrated with Realtek HD audio chip
Graphics	<p>Intel® UHD Graphics, shared memory for:</p> <ul style="list-style-type: none"> 1* HDM12.0b 1* 24 bits Dual CH LVDS or 1* eDP by 1 Lane (Default: LVDS) <p><i>*Note: Support Dual Displays.</i></p>
BIOS	<ul style="list-style-type: none"> AMI 128Mb Flash ROM
Rear I/O	<ul style="list-style-type: none"> 1* USB3.1 (Gen.2) Type-C port 1* HDMI 2.0b 2* RJ-45 LAN port 1* USB2.0 port 1* USB3.1 (Gen.2) Type-A port

Internal I/O	<ul style="list-style-type: none"> ● 1* 9-pin USB2.0 header (Expansable to 2* USB 2.0 ports) ● 2* Serial port header (support RS232/422/485) ● 1* LVDS header ● 1* LVDS inverter header ● 1* 8-bit GPIO header ● 1* Nano SIM Card slot ● 1* 2-pin internal 12V DC-in power connector (DCIN2) ● 1* Front panel audio header ● 1* JBUZZ Header
TPM 2.0	<ul style="list-style-type: none"> ● Supported Intel® PTT (Integrated TPM)
OS Support	<ul style="list-style-type: none"> ● <i>for detailed OS support information please visit our website for latest update</i>

***Note:** The main differences among **MP21** series are listed as below:

Model	TPM2.0	Onboard 64GB eMMC
MP21-62100	<i>Intel® PTT</i>	N/A
MP21-62104	<i>Intel® PTT</i>	Yes

1-3 Layout Diagram

Rear IO Diagram:

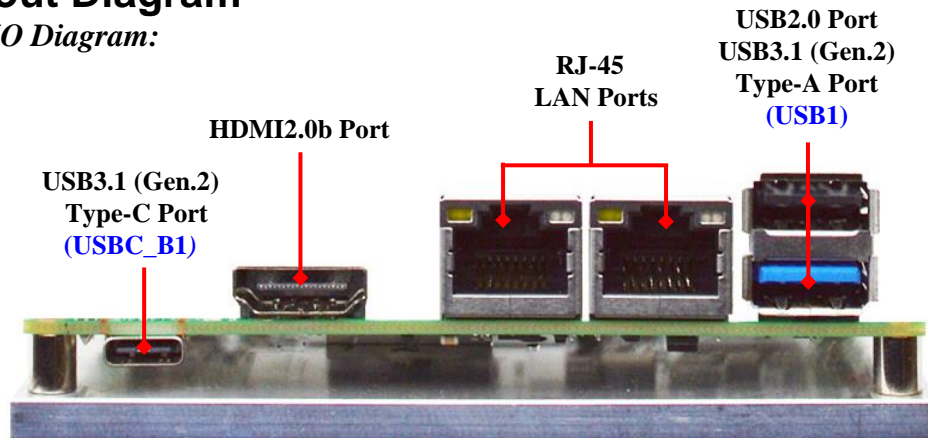

Diagram-Front Side and Jumper Positions:

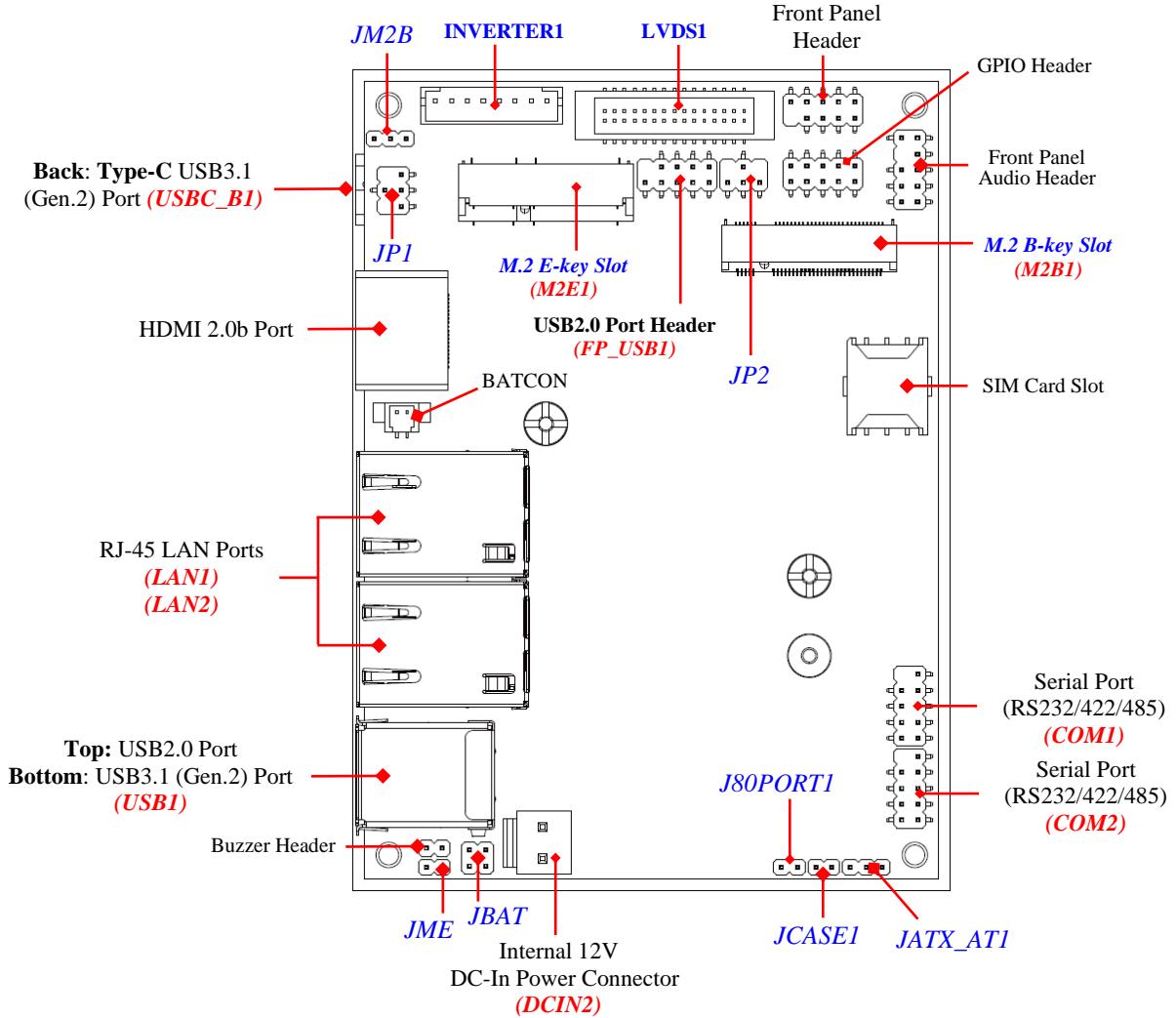
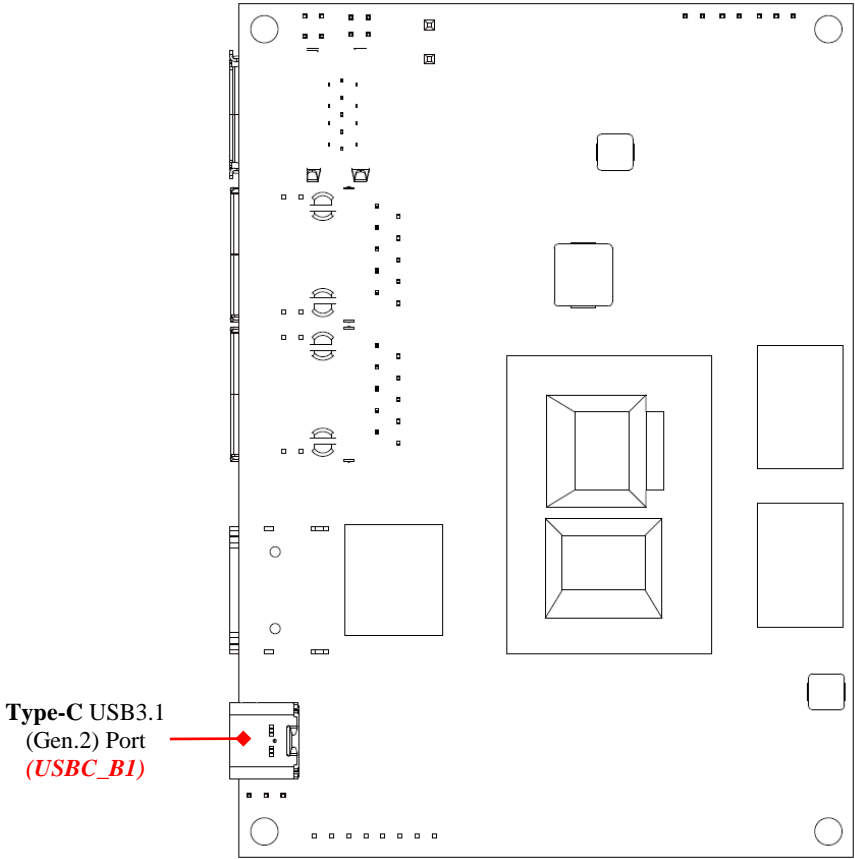

Diagram-Back Sid:



Jumpers

Jumper	Name	Description	Pitch
JM2B	M.2 B-key Power Select (VCC3 or 3VSB)	3-Pin Block	2.0mm
JP1	LVDS Backlight VCC 5V/12V/ADP 12V Function Select	4-Pin Block	2.0mm
JBUZZ	Buzzer Header	2-Pin Block	2.0mm
JME	ME Features Function Select	2-Pin Block	2.0mm
JBAT	PIN (1-2): Clear ME REG PIN (3-4): Clear CMOS	4-Pin Block	2.0mm
JP2	LVDS/LCD VCC 3.3V/5V/12V Function Select	4-Pin Block	2.0mm
J80PORT1	GPIO/80 Port Function Select	2-Pin Block	2.0mm
JCASE1	Case Open Message Display Function	2-Pin Block	2.0mm
JATX_AT1	ATX Mode/AT Mode Select	3-Pin Block	2.0mm

Connectors

Connector	Name
USBC_B1	USB3.1 (Gen.2) Type-C Port Connector
HDMI	HDMI2.0b Port Connector
LAN1/LAN2	RJ-45 LAN Port Connector X2
USB1	USB2.0 over USB3.1 (Gen.2) Port Connector
DCIN2	Internal 2-Pin 12V DC-in Power Connector

Headers

Header	Name	Description	Pitch
INVERTER1	LVDS Inverter Wafer	8-pin Block	2.0mm
LVDS1	LVDS Header	30-pin Block	1.25mm
JW_FP1	Front Panel Header (PWR LED/ HDD LED/Power Button /Reset)	9-pin Block	2.54mm
FP_USB1	USB2.0 Port Header	9-pin Block	2.0mm
GPIO_CON1	GPIO Port Header	10-pin Block	2.0mm
FP_AUDIO	Front Panel Audio Header	9-pin Block	2.0mm
JBUZZ	Buzzer Header	2-pin Block	2.0mm
COM1/2	RS232/422/485 Serial Port Header	9-pin Block	2.0mm

Chapter 2

Hardware Installation

2-1 Jumper Settings

JM2B (3-pin): M.2 B-key Power Select (2.0 pitch)

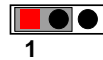
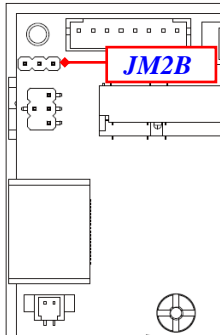

1-2 Closed: VCC3 (Default);

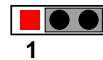

2-3 Closed: 3VSB.

JP1 (4-pin): LVDS Backlight VCC 5V/12V Select (2.0 pitch)

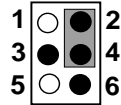
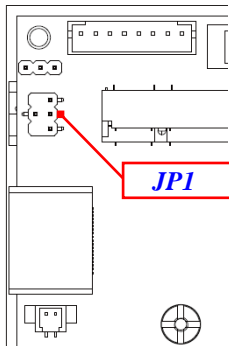

2-4 Closed:
VCC= +5V;

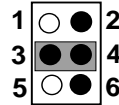

3-4 Closed:
VCC= +12V;

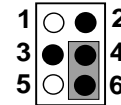

4-6 Closed:
VCC= ADP12V.

***Note:** Maximum current limit is 0.5A while using 5V/12V working voltage

JME (2-pin): ME Features Function Select (2.0 pitch)

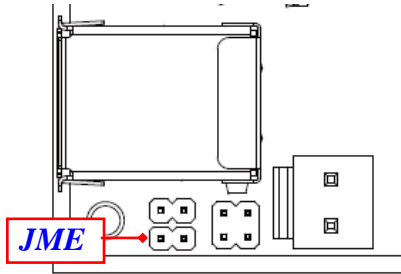

1-2 Open: Normal (Default);



1-2 Closed: ME Flash Override.

Pin (1-2) of JBAT (4-pin): Clear ME REG (2.0 pitch)

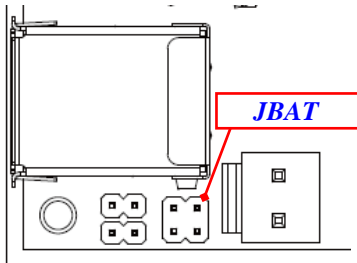

1-2 Open: Normal (Default);



1-2 Closed: Clear ME REG

Pin (3-4) of JBAT (4-pin): Clear CMOS (2.0 pitch)

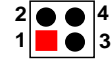
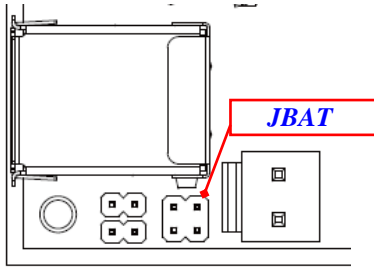

3-4 Open: Normal (Default);

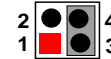

3-4 Closed: Clear CMOS.

JP2 (4-pin): LVDS/LCD VCC 3.3V/5V/12V Select (2.0 pitch)

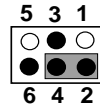
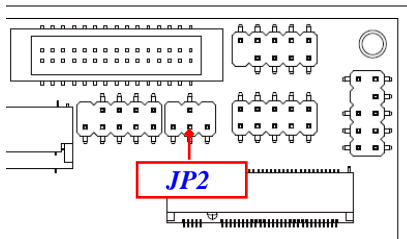

2-4 Closed:
VCC= VCC3;

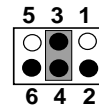

3-4 Closed:
VCC= +5V;

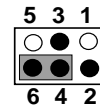

4-6 Closed:
VCC= +12V.

***Note:** Maximum current limit is 0.5A while using 5V/12V working voltage

J80PORT1 (2-pin): GPIO Header 80 Port/GPIO Function Select (2.0 pitch)

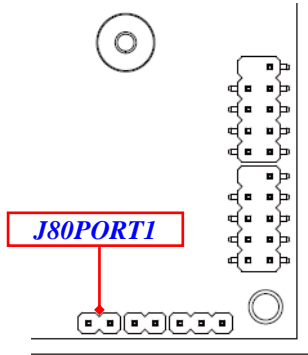

1-2 Open: GPIO_CON =80 Port;



1-2 Closed: GPIO_CON =GPIO Port (Default).

JCASE1 (2-pin): Case Open (2.0 pitch)

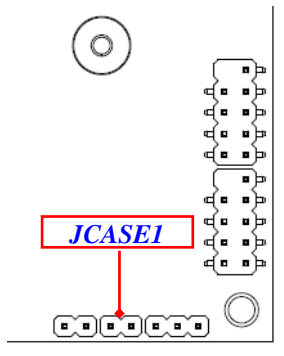

1-2 Open: Normal (Default);



1-2 Closed: Touch Case OPEN.

Pin (1-2) Closed: When Case open function pin short to GND, the Case open function was detected. When used, needs to enter BIOS and enable '**Case Open Detect**' function. In this case if your case is removed, next time when you restart your computer, a message will be displayed on screen to inform you of this.

JATX_AT1 (3-pin): ATX Mode/AT Mode Select (2.0 pitch)

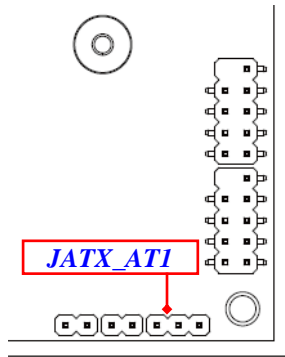

1-2 Closed: ATX Mode Selected (Default);





2-3 Closed: AT Mode Selected.

***ATX Mode Selected:** Press power button to power on after power input ready;
AT Mode Selected: Directly power on as power input ready.

2-2 Connectors, Headers and Wafers

2-2-1 Rear I/O Panel Connectors

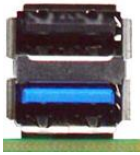
<i>Icon</i>	<i>Name</i>	<i>Function</i>
	Type-C USB3.2 (Gen.2) & DP1.4a Port	Type-C USB3.2 (Gen.2) port also supports ALT mode & PD 5V/3A.
	HDMI2.0b Port	For user to connect display device that support HDMI2.0b specification.
	RJ-45 LAN Port	This connector is standard RJ-45 LAN jack for Network connection which supports 10/100/1000 Mbps Ethernet data transfer rate.
	Type-A USB2.0 Port Over USB3.1 (Gen.2) Port	Top: To connect USB keyboard, mouse or other devices compatible with USB2.0 specification. Bottom: To connect USB keyboard, mouse or other devices compatible with USB3.1 (Gen.2) specification. Ports support up to 10Gbps data transfer rate.

Gigabit RJ-45 LAN port LED Signals:

** There are two LED next to the LAN port. Please refer to the table below for the LAN port LED indications.

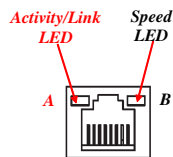

A: Activity/Link LED		B: Speed LED	
Status	Description	Status	Description
Off	No Link	Off	10Mbps connection
Blinking	Data Activity	Green	100Mbps connection
On	Link	Orange	1Gbps connection

2-2-2 Motherboard Internal Connectors

(1) BATCON (2-pin): Battery Connector

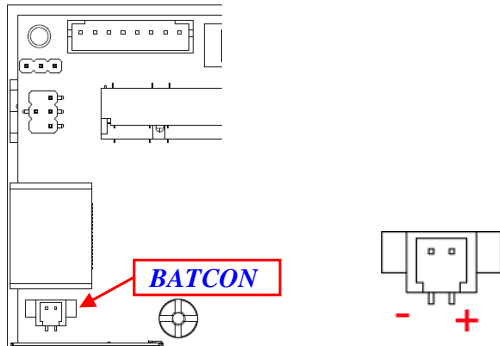

(2) DCIN2 (2-pin): Internal 12V DC-in Power Connector

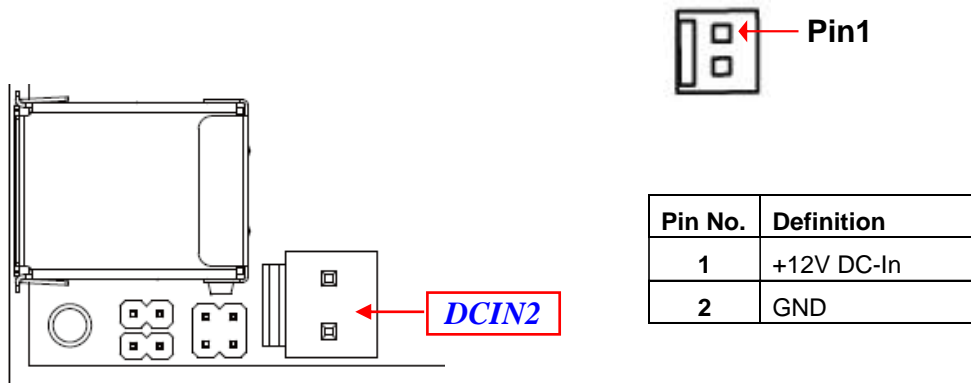

***Note:** Maximum current limit is **40W** while using **12V** working voltage

2-2-3 Pin Definition for Headers & Wafers

INVERTER1 (8-pin): LVDS Inverter Connector (2.0 pitch)

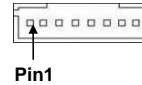
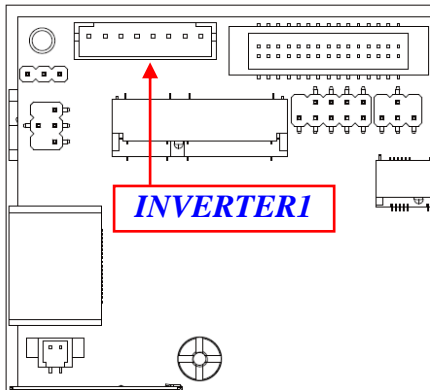

Pin No.	Definition
1	Backlight Enable
2	Backlight PWM
3	Backlight LED VCC
4	Backlight LED VCC
5	GND
6	GND
7	Backlight Up SW
8	Backlight Down SW

Warning! Find **Pin-1** location of the inverter and make sure that the installation direction is correct! Otherwise serious harm will occur to the board/display panel!!

LVDS1 (30-pin): LVDS Port Header (1.25 pitch)

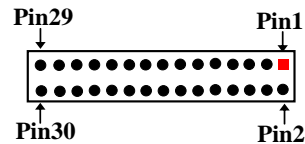
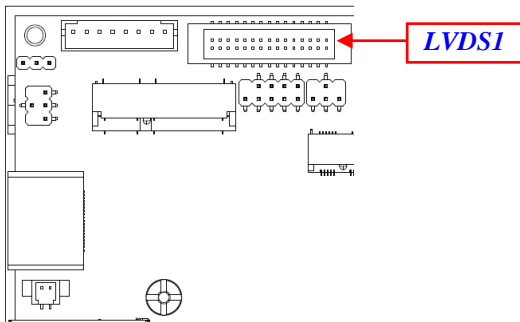

Pin Define	Pin No.	Pin No.	Pin Define
LVDSB_DATAN3	Pin 1	Pin 2	LVDSB_DATAP3
LVDS_CLKBN	Pin 3	Pin 4	LVDS_CLKBP
LVDSB_DATAN2	Pin 5	Pin 6	LVDSB_DATAP2
LVDSB_DATAN1	Pin 7	Pin 8	LVDSB_DATAP1
LVDSB_DATAN0	Pin 9	Pin 10	LVDSB_DATAP0
CH_SDA	Pin 11	Pin 12	CH_SCL
GND	Pin 13	Pin 14	GND/LVDS_DETECT
GND	Pin 15	Pin 16	GND
LVDSA_DATAP3	Pin 17	Pin 18	LVDSA_DATAN3
LVDS_CLKAP	Pin 19	Pin 20	LVDS_CLKAN
LVDSA_DATAP2	Pin 21	Pin 22	LVDSA_DATAN2
LVDSA_DATAP0	Pin 23	Pin 24	LVDSA_DATAN1
LVDSA_DATAP0	Pin 25	Pin 26	LVDSA_DATAN0
LCD_VCC	Pin 27	Pin 28	LCD_VCC
LCD_VCC	Pin 29	Pin 30	LCD_VCC

JW_FP1 (10-pin): Front Panel Function Select (2.54 pitch)

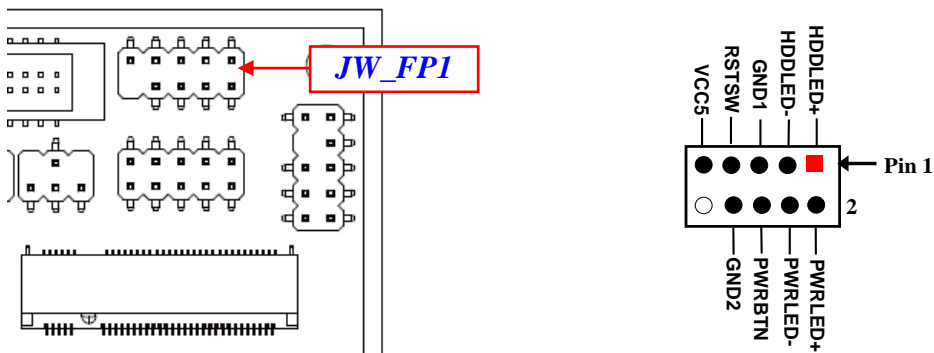

***Note:** Maximum current limit is **1A** while using **5V** working voltage

FP_USB1 (9-pin): USB 2.0 Port Header (2.0 pitch)

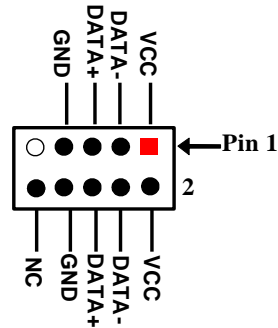
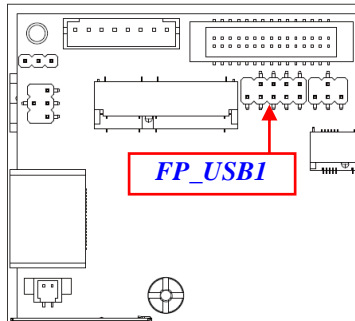

***Note:** Maximum current limit is **0.5A** while using **5V** working voltage

GPIO_CON1 (10-pin): GPIO Port Header (2.0 pitch)

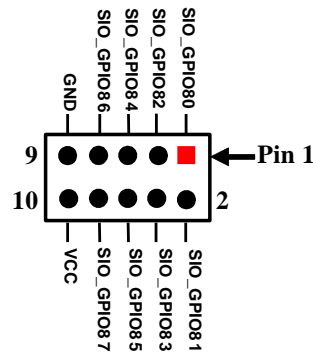
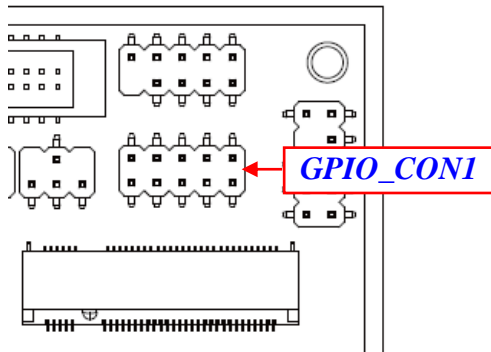

***Note:** Please refer to **Page 11 J80PORT1** jumper setting for GPIO_CON header **GPIO Port** or **80 Port** function select.

FP_AUDIO (9-pin): Front Panel Audio Header (2.0 pitch)

This header connects to Front Panel Line-out, MIC-In connector with cable.

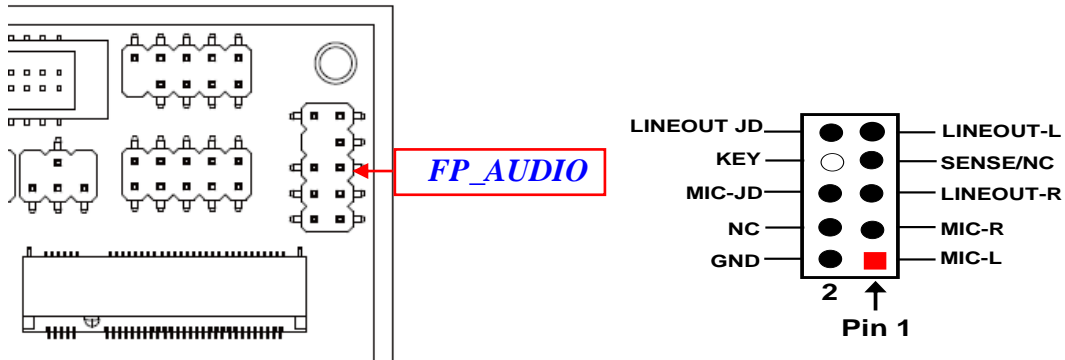

COM1/2 (9-pin): RS232/422/485 Serial Port Headers (2.0 pitch)

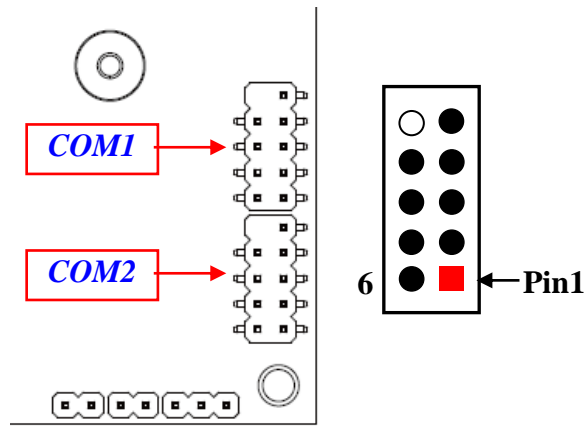

Pin NO.	RS232	RS422	RS485
Pin 1	DCD	TX-	DATA-
Pin 2	RXD	TX+	DATA+
Pin 3	TXD	RX+	NC
Pin 4	DTR	RX-	NC
Pin 5	GND	GND	GND
Pin 6	DSR	NC	NC
Pin 7	RTS	NC	NC
Pin 8	CTS	NC	NC
Pin 9	RI	NC	NC

JBUZZ (2-pin): Buzzer Headers (2.0 pitch)

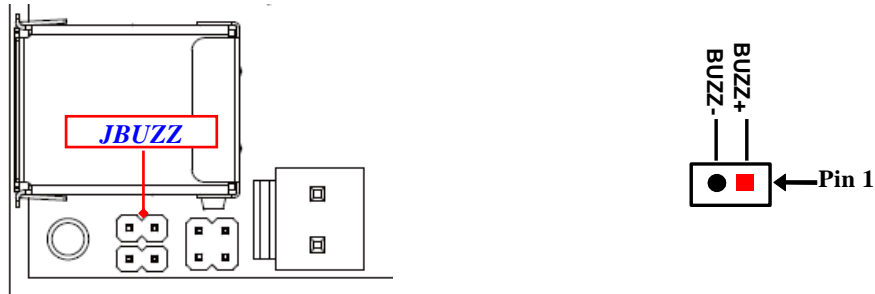

2-2-4 Maximum Voltage & Current Limit

Below is a list of maximum voltage & Current Limit specification for motherboard interface (including but not limited to slots, connectors and headers) for setup reference:

Parts		Working Voltage	Current Support
USB Port from	USBC_B1 (Type-C)	5V	3A
	USB1	5V	Top (USB2.0): 0.5A Bottom (USB3.1): 0.9A
	FP_USB1	5V	0.5A
	FP_USB2	5V	0.5A
JW_FP1		5V	1A
LVDS1		3.3V/5V/12V (via jumper setting)	2A
INVERTER1		5V/12V/ADP12V (via jumper setting)	2A
GPIO_CON1		5V	1A
JP1		5V/12V/ADP12V	2A
JP2		3.3V/5V/12V	2A
DCIN2		12V	40W

Chapter 3

Introducing BIOS

Notice! The BIOS options in this manual are for reference only. Different configurations may lead to difference in BIOS screen and BIOS screens in manuals are usually the first BIOS version when the board is released and may be different from your purchased motherboard. Users are welcome to download the latest BIOS version form our official website.

The BIOS is a program located on a Flash Memory on the motherboard. This program is a bridge between motherboard and operating system. When you start the computer, the BIOS program will gain control. The BIOS first operates an auto-diagnostic test called POST (power on self test) for all the necessary hardware, it detects the entire hardware device and configures the parameters of the hardware synchronization. Only when these tasks are completed done it gives up control of the computer to operating system (OS). Since the BIOS is the only channel for hardware and software to communicate, it is the key factor for system stability, and in ensuring that your system performance as its best.

3-1 Entering Setup

Power on the computer and by pressing immediately allows you to enter Setup.

If the message disappears before your respond and you still wish to enter Setup, restart the system to try again by turning it OFF then ON or pressing the “RESET” button on the system case. You may also restart by simultaneously pressing <Ctrl>, <Alt> and <Delete> keys. If you do not press the keys at the correct time and the system does not boot, an error message will be displayed and you will again be asked to

Press to enter Setup/ Press <F7> to enter Popup Menu.

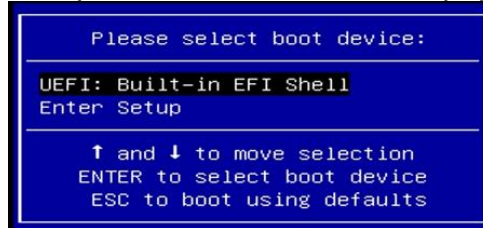

3-2 BIOS Menu Screen

The following diagram show a general BIOS menu screen:

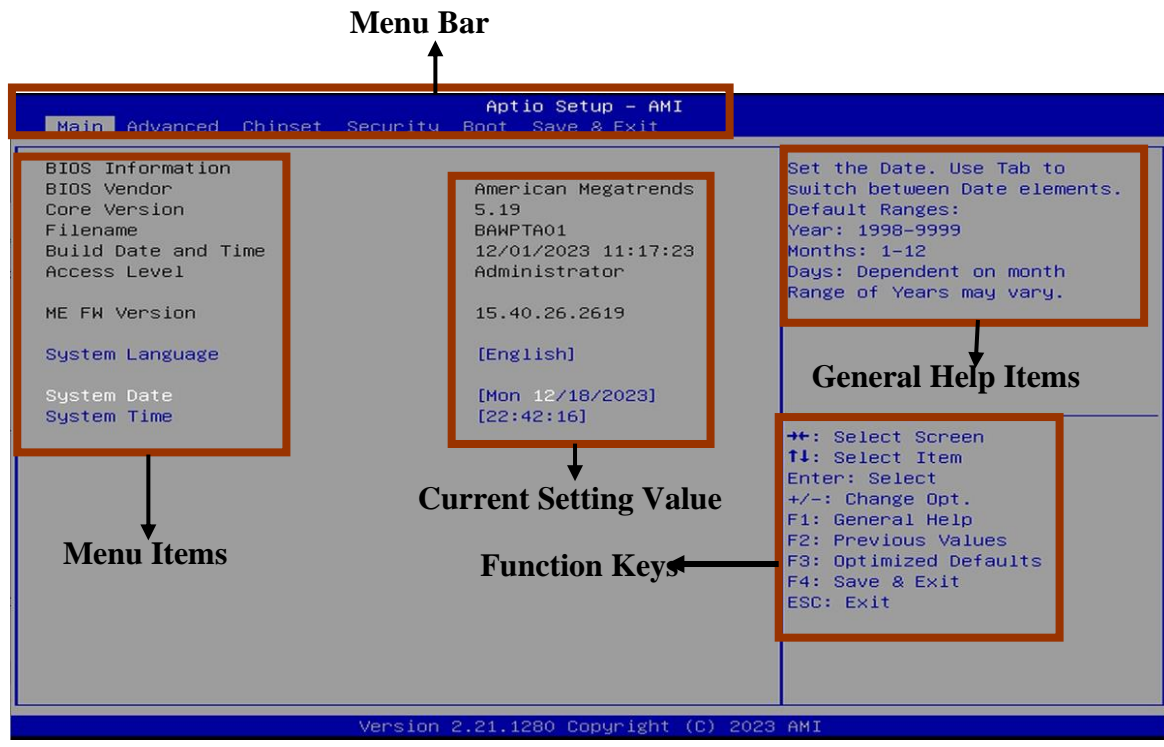

3-3 Function Keys

In the above BIOS Setup main menu of, you can see several options. We will explain these options step by step in the following pages of this chapter, but let us first see a short description of the function keys you may use here:

- Press ←→ (left, right) to select screen;
- Press ↑↓ (up, down) to choose, in the main menu, the option you want to confirm or to modify.
- Press <Enter> to select.
- Press <+>/<-> keys when you want to modify the BIOS parameters for the active option.
- [F1]: General help.
- [F2]: Previous value.
- [F3]: Optimized defaults.
- [F4]: Save & Exit.
- Press <Esc> to quit the BIOS Setup.

3-4 Getting Help

Main Menu

The on-line description of the highlighted setup function is displayed at the top right corner the screen.

Status Page Setup Menu/Option Page Setup Menu

Press [F1] to pop up a small help window that describes the appropriate keys to use and the possible selections for the highlighted item. To exit the Help Window, press <Esc>.

3-5 Menu Bars

There are six menu bars on top of BIOS screen:

Main	To change system basic configuration
Advanced	To change system advanced configuration
Chipset	To change chipset configuration
Security	Password settings
Boot	To change boot settings
Save & Exit	Save setting, loading and exit options.

User can press the right or left arrow key on the keyboard to switch from menu bar. The selected one is highlighted.

3-6 Main Menu

Main menu screen includes some basic system information. Highlight the item and then use the <+> or <-> and numerical keyboard keys to select the value you want in each item.

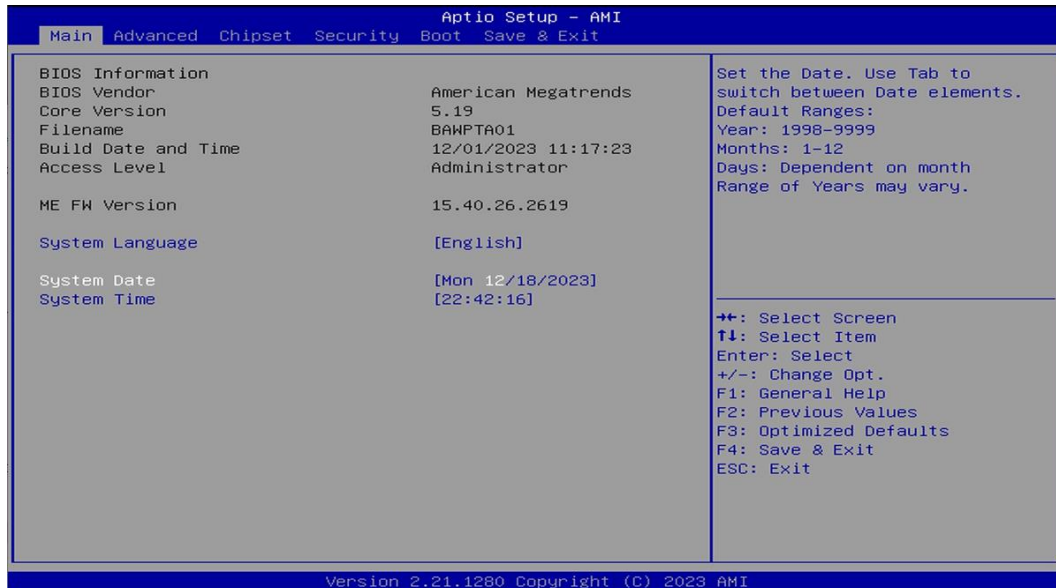

System Date

Set the date. Please use [Tab] to switch between date elements.

System Time

Set the time. Please use [Tab] to switch between time elements.

3-7 Advanced Menu

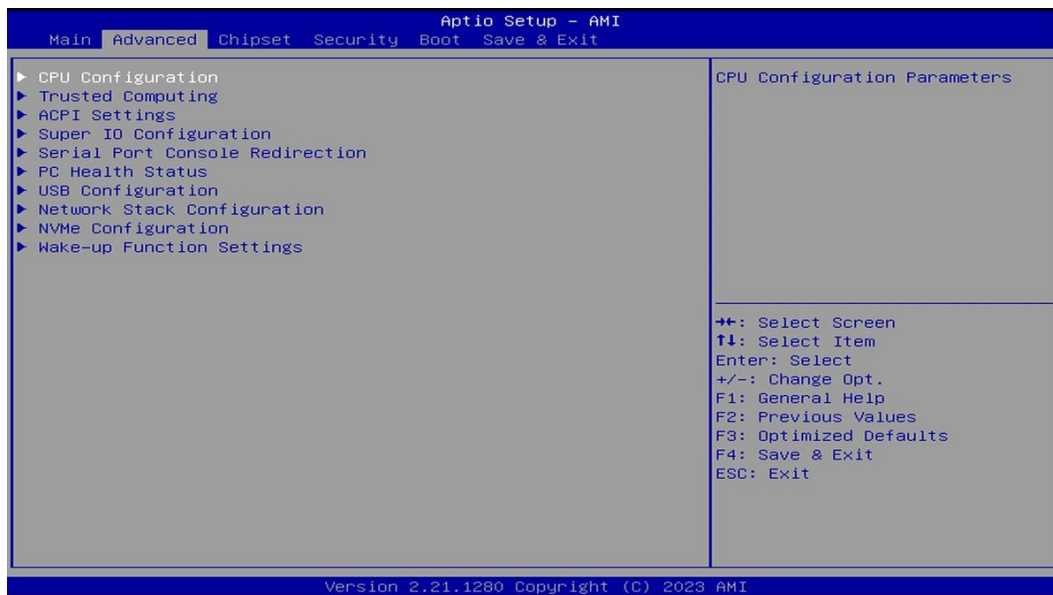

▶ CPU Configuration

Press [Enter] to make settings for the following sub-items.

Boot Performance Mode

Use this item to select the performance state that the BIOS will set starting from reset vector.

The optional settings: [Max Battery]; [Max Non-Turbo Performance]; [Turbo Performance]

Intel(R) SpeedStep (tm)

Use this item to allows more than two frequency ranges to be supported.

The optional settings: [Disabled]; [Enabled].

When set as [Enabled], the following item shall appear:

Turbo Mode

Use this item to enable/disable processor Turbo Mode (requires EMTTM enabled too). AUTO means enabled.

C states

Use this item to enable/disable CPU Power Management. Allows CPU to go to C states when it's not 100% utilized.

The optional settings: [Disabled]; [Enabled].

When set as [Enabled], the following item shall appear:

Enhanced C-states

Use this item to enable/disable C1E. When enabled, CPU will switch to minimum speed when all cores enter C-State

The optional settings: [Disabled]; [Enabled].

Package C State Limit

Use this item to Maximum Package C State Limit Setting. CPU Default: Leaves to Factory default value.

Auto: Initializes to deepest available Package C State Limit.

The optional settings: [C0/C1]; [C2]; [C3]; [C6]; [C7]; [C7S]; [C8]; [C9]; [C10]; [CPU Default]; [Auto]

Power Limit 1 Override

Use this item to enable/disable Power Limit 1 override. If this option is disable, BIOS will program the default values for Power Limit 1 and Power Limit 1 Time Window.

The optional settings: [Disabled]; [Enabled].

Power Limit 1

Use this item to power Limit 1 in Milli Watts. BIOS will round to the nearest 1/8W when programming. 0= no custom override. For 12.50W, enter 12500. Overclocking SKU: Value must be between Max and Min Power Limits (specified by PACKAGE_POWER_SKU_MSR). Other SKUs: This value must be between Min Power Limit and TDP Limit. If value is 0, BIOS will program TDP value.

Power Limit 1 Time Window

Use this item to power Limit 1 Time Window value in seconds. The value may vary from 0 to 128. 0=default value (28 sec for Mobile and 8 sec for desktop). Defines time Window which TDP value should be maintained.

The optional settings: [0]; [1]; [2]; [3]; [4]; [5]; [6]; [7]; [8]; [10]; [12]; [14]; [16]; [20]; [24]; [28]; [32]; [40]; [48]; [56]; [64]; [80]; [96]; [112]; [128]

Power Limit 2 Override

Use this item to enabled/disable power Limit 2 override. If this option is disabled, BIOS will program the default values for Power Limit 2.

The optional settings: [Disabled]; [Enabled].

When set as [Enabled], user can make further settings in the following items:

Power Limit 2

Use this item to power Limit 2 value in Milli watts. BIOS will round to the nearest 1/8W when programming. If the value is 0, BIOS will program this value as 1.25*TDP. For 12.50W, enter 12500. Processor applies control policies such that the package power does not exceed this limit.

▶ **Trusted Computing**

Press [Enter] to enable or disable 'Security Device Support'

TPM20 Device Found

Security Device Support

Use this item to Enables or Disables BIOS support for security device. O.S. will not show Security Device. TCG EFI protocol and INT1A interface will not be available.

The optional settings: [Disabled]; [Enabled].

When set as [**Enabled**], user can make further settings in the following items:

Active PCR Banks

Available PCR Banks

SHA256 PCR Bank

Use this item to Enable or Disable SHA256 PCR Bank
The optional settings: [Disabled]; [Enabled].

SHA384 PCR Bank

Use this item to Enable or Disable SHA384 PCR Bank
The optional settings: [Disabled]; [Enabled].

SM3_256 PCR Bank

Use this item to Enable or Disable SM3_256 PCR Bank
The optional settings: [Disabled]; [Enabled].

Pending Operation

Use this item to schedule an operation for the security device

NOTE: Your computer will reboot during restart in order to change state of security device

The optional settings: [None]; [TPM Clear].

▶ **ACPI Settings**

Press [Enter] to make settings for the following sub-item:

ACPI Sleep State

Use this item to select the highest ACPI sleep state the system will enter when the SUSPEND button is pressed.

The optional settings: [Suspend Disabled]; [S3(Suspend to RAM)].

▶ **Super I/O Configuration**

Press [Enter] to make settings for the following sub-item:

Super IO Configuration

▶ **Serial Port 1 Configuration**

Use this item to set parameters of serial port 1 (COMA)

Press [Enter] to make settings for the following sub-item:

Serial Port

Use this item to enable or disable serial port (COM)

The optional settings: [Disabled]; [Enabled]

When set as [**Enabled**], user can make further settings in the following items:

Device Settings

Change Settings

Use this item to select an optimal settings for super IO device

The optional settings: [Auto]; [IO= 3F8h; IRQ=4]; [IO= 2F8h; IRQ=3]; [IO= 3E8h; IRQ=4]; [IO= 2E8h; IRQ=3]

Transmission Mode Select

The optional settings: [RS422]; [RS232]; [RS485]

Mode Speed Select

Use this item to RS232/RS422/RS485 Speed Select

The optional settings: [RS232/RS422/RS485=250kps]; [RS232=1Mbps, RS422/RS485= 10Mbps]

▶ **Serial Port 2 Configuration**

Serial Port

Use this item to enable or disable serial port (COM)

The optional settings: [Disabled]; [Enabled]

When set as **[Enabled]**, user can make further settings in the following items:

Device Settings

Change Settings

Use this item to select an optimal settings for super IO device

The optional settings: [Auto]; [IO= 3F8h; IRQ=4]; [IO= 2F8h; IRQ=3]; [IO= 3E8h; IRQ=4]; [IO= 2E8h; IRQ=3]

Transmission Mode Select

The optional settings: [RS422]; [RS232]; [RS485]

Mode Speed Select

Use this item to RS232/RS422/RS485 Speed Select

The optional settings: [RS232/RS422/RS485=250kps]; [RS232=1Mbps, RS422/RS485= 10Mbps]

ERP Support

Use this item to Energy-Related Products function. Disable ERP to active all wake-up functions.

The optional settings: [Disabled]; [Enabled].

Case Open Detect

Use this item to detect if case have ever been opened. Show message in POST.
The optional settings: [Disabled]; [Enabled].

When set as [Enabled], system will detect if COPEN has been short or not (*refer to **JCASE** jumper setting for Case Open Detection*); if Pin 1-2 is short, system will show Case Open Message during POST.

WatchDog Reset Timer

Use this item to support WDT reset function

The optional settings: [Disabled]; [Enabled].

When set as [**Enabled**], user can make further settings in the following items:

WatchDog Reset Timer Value

User can select a value in the range of [10] to [255] seconds when '**WatchDog Reset Timer Unit**' set as [Sec]; or in the range of [1] to [255] minutes when '**WatchDog Reset Timer Unit**' set as [Min].

WatchDog Reset Timer Unit

The optional settings: [Sec.]; [Min.].

WatchDog Wake-up Timer

User this item to support WDT Wake-up

The optional settings: [Disabled]; [Enabled].

When set as [**Enabled**], user can make further settings in the following items:

WatchDog Wake-up Timer Value

User can select a value in the range of [10] to [255] seconds when '**WatchDog Wake-up Timer Unit**' set as [Sec]; or in the range of [1] to [255] minutes when '**WatchDog Wake-up Timer Unit**' set as [Min].

WatchDog Wake-up Timer Unit

The optional settings: [Sec.]; [Min.].

ATX Power Emulate AT Power

This item support Emulate AT power function, MB power On/Off control by power supply. Use needs to select 'AT or ATX Mode' on MB jumper at first (refer to JATX_AT1 jumper setting Pin 1&2 of for ATX Mode & Pin 2&3 of AT Mode Select)

▶ **Serial Port Console Redirection**

User this item to serial port console redirection
Press [Enter] to make settings for the following sub-item:

COM1

Console Redirection

User this item to Console Redirection Enable or Disable
The optional settings: [Disabled]; [Enabled].

When set as **[Enabled]**, user can make further settings in the following items:

▶ **Console Redirection Settings**

User this item to the settings specify how the host computer and the remote computer (which the user is using) will exchange data. Both computers should have the same or compatible settings

Press [Enter] to make settings for the following sub-item:

Terminal Type

The optional settings: [VT100]; [VT100+]; [VT-UTF8]; [ANSI].

Emulation: [ANSI]: Extended ASCII char set; [VT100]: ASCII char set; [VT100+]: Extends VT100 to support color, function keys, etc.; [VT-UTF8]: Uses UTF8 encoding to map Unicode chars onto 1 or more bytes.

Bits per second

Use this item to select serial port transmission speed. The speed must be matched on the other side. Long or noisy lines may require lower speeds.

The optional settings: [9600]; [19200]; [38400]; [57600]; [115200].

Data Bits

Use this item to data bits

The optional settings: [7]; [8]

Parity

A parity bit can be sent with the data bits to detect some transmission errors.

The optional settings: [None]; [Even]; [Odd]; [Mark]; [Space].

[Even]: parity bit is 0 if the num of 1's in the data bits is even; [Odd]: parity bit is 0 if num of 1's in the data bits is odd; [Mark]: parity bit is always 1; [Space]: Parity bit is always 0; [Mark] and [Space] Parity do not allow for error detection.

Stop Bits

Stop bits indicate the end of a serial data packet. (A start bit indicates the beginning). The standard setting is 1 stop bit. Communication with slow devices may require more than 1 stop bit.

The optional settings: [1]; [2].

Flow Control

Flow control can prevent data loss from buffer overflow. When sending data, if the receiving buffers are full, a “stop” signal can be sent to stop the data flow. Once the buffers are empty, a “start” signal can be sent to re-start the flow. Hardware flow control uses two wires to send start/stop signals.

The optional settings: [None]; [Hardware RTS/CTS].

VT-UTF8 Combo key Support

Use this item to enable VT-UTF8 combination key support for ANSI/VT100 terminals.

The optional settings: [Disabled]; [Enabled].

Recorder Mode

Use this item to with this mode enabled only text will be sent. This is to capture Terminal data.

The optional settings: [Disabled]; [Enabled].

Resolution 100X31

Use this item to Enables or disables extended terminal resolution

The optional settings: [Disabled]; [Enabled].

Putty KeyPad

Use this item to select FunctionKey and KeyPad on Putty

The optional settings: [VT100]; [Linux]; [XTERMR6]; [SCO]; [ESCN]; [VT400].

Serial Port for Out-of-Band Management/

Windows Emergency Management Services (EMS)

Console Redirection EMS

The optional settings: [Disabled]; [Enabled]. When set as [Enabled], the following sub-items shall appear:

- ▶ **Console Redirection Settings**

The settings specify how the host computer and the remote computer (which the user is using) will exchange data. Both computers should have the same or compatible settings.

Press [Enter] to make settings for the following items:

Out-of-Band Mgmt Port

The optional setting is: [COM1].

Terminal Type EMS

The optional settings: [VT100]; [VT100+]; [VT-UTF8]; [ANSI].

[VT-UTF8] is the preferred terminal type for out-of-band management. The next best choice is [VT100+] and then [VT100]. See above, in Console Redirection Settings page, for more help with Terminal Type/Emulation.

Bits per second

Use this item to select serial port transmission speed. The speed must be matched on the other side. Long or noisy lines may require lower speeds.

The optional settings: [9600]; [19200]; [57600]; [115200].

Flow Control

Flow control can prevent data loss from buffer overflow. When sending data, if the receiving buffers are full, a “stop” signal can be sent to stop the data flow. Once the buffers are empty, a “start” signal can be sent to re-start the flow. Hardware flow control uses two wires to send start/stop signals.

The optional settings: [None]; [Hardware RTS/CTS]; [Software Xon/Xoff].

Data Bits EMS

The default setting is: [8].

**This item may or may not show up, depending on different configuration.*

Parity EMS

The default setting is: [None].

**This item may or may not show up, depending on different configuration.*

Stop Bits EMS

The default setting is: [1].

**This item may or may not show up, depending on different configuration*

▶ **PC Health Status**

Press [Enter] to view current hardware health status

▶ **USB Configuration**

Press [Enter] to make settings for the following sub-items:

USB Configuration

XHCI Hand-off

This is a workaround for Oses without XHCI hand-off support. The XHCI ownership change should be claimed by XHCI driver.

The optional settings are: [Enabled]; [Disabled].

USB Mass Storage Driver Support

The optional settings are: [Disabled]; [Enabled].

USB Hardware Delays and Time-outs:

USB Transfer Time-out

Use this item to set the time-out value for control, bulk, and interrupt transfers.

The optional settings are: [1 sec]; [5 sec]; [10 sec]; [20 sec].

Device Reset Time-out

Use this item to set USB mass storage device start unit command time-out.

The optional settings are: [10 sec]; [20 sec]; [30 sec]; [40 sec].

Device Power-up Delay

Use this item to set maximum time the device will take before it properly reports itself to the host controller.

The optional settings: [Auto]; [Manual].

'Auto' uses default value: for a root port it is 100 ms, for a hub port the delay is taken from hub descriptor.

Select [Manual] you can set value for the following sub-item: '**Device Power-up Delay in Seconds**'.

Device Power-up Delay in Seconds

The delay range is from [1] to [40] seconds, in one second increments.

▶ **Network Stack Configuration**

Press [Enter] to go to '**Network Stack**' screen to make further settings.

Network Stack

Use this item to enable or disable UEFI Network Stack.

The optional settings are: [Enabled]; [Disabled].

When set as [Enabled], the following sub-items shall appear:

Ipv4 PXE Support

The optional settings are: [Disabled]; [Enabled].

Use this item to enable Ipv4 PXE Boot Support. When set as [Disabled], Ipv4 boot option will not be created.

Ipv6 PXE Support

The optional settings are: [Disabled]; [Enabled].

Use this item to enable Ipv6 PXE Boot Support. When set as [Disabled], Ipv6 boot option will not be created.

PXE boot wait time

Use this item to wait time in seconds to press ESC key to about the PXE boot. Use either +/- or numeric Keys to set the value.

Media Detect Count

Use this item to set number of times presence of media will be checked. The optional setting range is from [1] to [50].

▶ **NVMe Configuration**

Press [Enter] to make settings for the following sub-items:

**Note: options only when NVME device is available.*

▶ **Wake-up Function Settings**

Press [Enter] to make settings for the following sub-items:

Wake-up System with Fixed Time

Use this item to enable or disable system wake-up on alarm event.

The optional settings: [Disabled]; [Enabled].

When set as [Enabled], system will wake on the hour/min/sec specified.

Wake-up Hour

Use this item to select 0-23. For example enter 3 for 3am and 15 for 3pm.

Wake-up Minute

Use this item to select 0-59.

Wake-up Second

Use this item to select 0-59.

Wake-up System with Dynamic Time

Use this item to enable or disable system wake-up on alarm event.

The optional settings: [Disabled]; [Enabled].

When set as [Enabled], system will wake on the current time + increased minute(s). The settings range is from [1] ~ [60] minute(s).

Wake-up Time Increase

Use this item to 1 to 60 minute(s)

USB Power Gating S4-S5

Use this item to USB Wake-up is affected by ERP function in S4. Please disable ERP before activating this function in S4.

The optional settings: [Disabled]; [Enabled].

PCIe Wake-up from S3-S5

The optional settings: [Enabled]; [Disabled].

3-8 Chipset

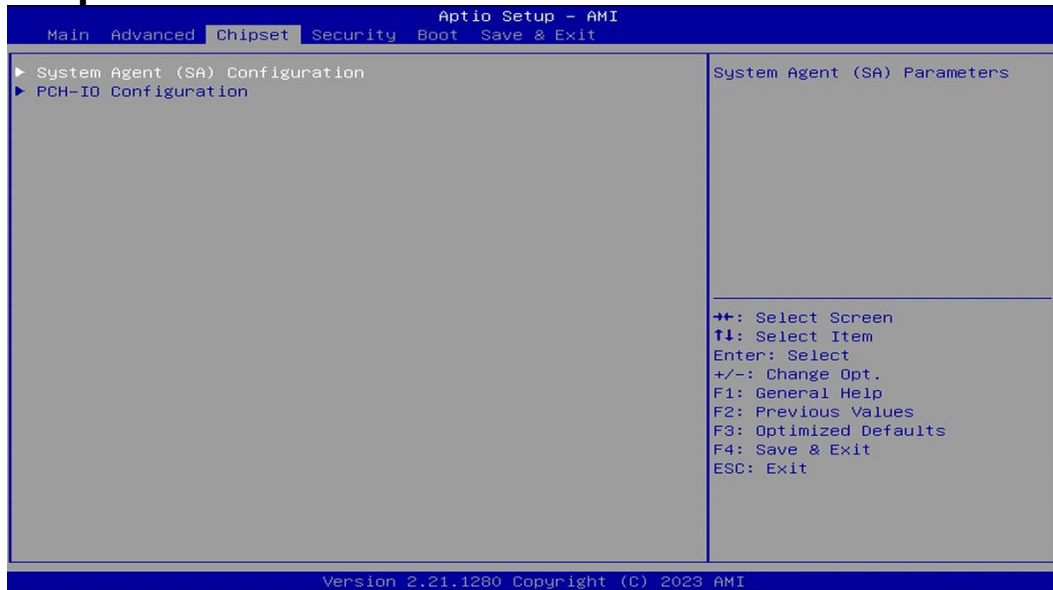

▶ System Agent (SA) Configuration

Press [Enter] to make settings for the following sub-items:

System Agent (SA) Configuration

GTT Size

Use this item to select the GTT Size.

The optional settings: [2MB]; [4MB]; [8MB].

DVMT Pre-Allocated

Use this item to select DVMT 5.0 Pre-Allocated (Fixed) Graphics Memory size used by the Internal Graphics Device.

The optional settings: [0M]; [4M]; [8M]; [12M]; [16M]; [20M]; [24M]; [28M]; [32M]; [36M]; [40M]; [44M]; [48M]; [52M]; [56M]; [60M]; [64M]; [96M]; [128M]; [160M]

DVMT Total Gfx Mem

Use this item to select DVMT 5.0 Total Graphic Memory size used by the Internal Graphics Device.

The optional settings: [128M]; [256M]; [MAX].

Active LFP

The optional settings: [Disabled]; [Enabled]

LVDS Panel Type

The optional settings: [800x480 1ch 18-bit]; [800x600 1ch 18-bit]; [800x600 1ch 24-bit]; [1024x600 1ch 18-bit]; [1024x768 1ch 18-bit]; [1024x768 1ch 24-bit]; [1280x800 1ch 18-bit]; [1280x800 1ch 24-bit]; [1366x768 1ch 18-bit]; [1366x768 1ch 24-bit]; [1440x900 2ch 18-bit]; [1440x900 2ch 24-bit]; [1280x1024 2ch 24-bit]; [1680x1050 2ch 24-bit]; [1920x1080 2ch 24-bit]; [eDP].

Backlight Control

Use this item to back light control setting

The optional settings: [PWM Inverted]; [PWM Normal]

Memory Date Rate

Total Memory

VT-d

VT-d

The optional settings: [Disabled]; [Enabled]

► **PCH-IO Configuration**

Press [Enter] to make settings for the following sub-items:

PCH-IO Configuration

▶ **PCI Express Configuration**

Peer Memory Write Enable

Use this item to enable or disable peer memory write.

The optional settings: [Disabled]; [Enabled]

▶ **SATA Configuration**

SATA Controller

Use this item to enable or disable SATA device.

The optional settings: [Disabled]; [Enabled].

When set as **[Enabled]**, the following sub-items shall appear:

SATA Mode Selection

This item determines how SATA controller(s) operate.

The optional settings: [AHCI].

M.2

M.2

The optional settings: [Disabled]; [Enabled].

HD-Audio Support

The optional settings: [Disabled]; [Enabled].

SCS eMMC Support

The optional settings: [Disabled]; [Enabled]

System State after Power Failure

Use this item to specify what state to go to when power is re-applied after a power failure

The optional settings: [Always On]; [Always off]; [Former State]

3-9 Security Menu

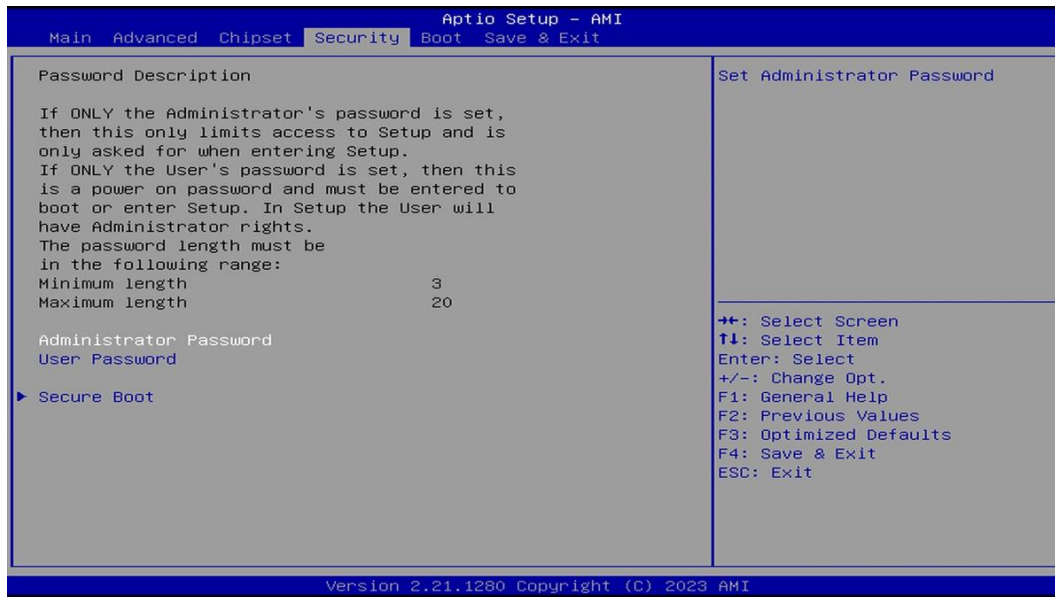

Security menu allow users to change administrator password and user password settings.

Administrator Password

If there is no password present on system, please press [Enter] to create new setup administrator password. If password is present on system, please press [Enter] to verify old password then to clear/change password. Press again to confirm the new administrator password.

User Password

If there is no password present on system, please press [Enter] to create new user password. If password is present on system, please press [Enter] to verify old password then to clear/change password. Press again to confirm the new user password.

▶ **Secure Boot**

Press [Enter] to make customized secure settings:

Secure Boot

Secure Boot feature is active if Secure Boot is enabled, Platform Key (PK) is enrolled and the system is in User mode. The mode change requires platform reset.

The optional settings are: [Disabled]; [Enabled].

Secure Boot Mode

Set UEFI Secure Boot Mode to Standard mode or Custom mode. This change is effective after save. After reset, this mode will return to Standard mode.

In Custom mode, Secure Boot Policy variables can be configured by a physically present user without full authentication.

The optional settings are: [Standard]; [Custom].

When set as [Custom**], user can make further settings in the following items that show up:*

- ▶ **Restore Factory Keys**

Use this item to force system to User Mode, to install factory default Secure Boot key databases.

- ▶ **Reset To Setup Mode**

Use this item to delete all Secure Boot Key databases from NVRAM.

- ▶ **Key Management**

This item enables expert users to modify Secure Boot Policy variables without full authentication. Press [Enter] to make settings for the following sub-items:

Factory Key Provision

This item is for user to install factory default secure boot keys after the platform reset and while the system is in Setup mode.

The optional settings are: [Disabled]; [Enabled].

- ▶ **Restore Factory Keys**

Use this item to force system into User Mode. Install factory default Secure Boot Key databases.

- ▶ **Reset to Setup Mode**

Use this item to delete all Secure Boot key databases from NVRAM.

- ▶ **Export Secure Boot variables**

Use this item to copy NVRAM content of Secure Boot variables to files in a root folder on a file system device.

▶ **Enroll Efi Image**

This item allows the image to run in Secure Boot Mode.

Enroll SHA256 Hash certificate of a PE image into Authorized Signature Database (db).

Device Guard Ready

▶ **Remove 'UEFI CA' from DB**

Device Guard ready system must not list 'Microsoft EFI CA' Certificate in Authorized Signature database (db).

▶ **Restore DB defaults**

Use this item to restore DB variable to factory defaults.

Secure Boot Variable/Size/Keys/Key Source

▶ **Platform Key (PK)/Key Exchange Keys/Authorized Signature/Forbidden Signature/ Authorized TimeStamps/OS Recovery Signatures**

Use this item to enroll Factory Defaults or load the keys from a file with:

1. Public Key Certificate in:

- a) EFI_SIGNATURE_LIST
- b) EFI_CERT_X509 (DER)
- c) EFI_CERT_RSA2048 (bin)
- d) EFI_CERT_SHAXXX

2. Authenticated UEFI Variable

3. EFI PE/COFF Image (SHA256)

Key Source: Factory, External, Mixed.

3-10 Boot

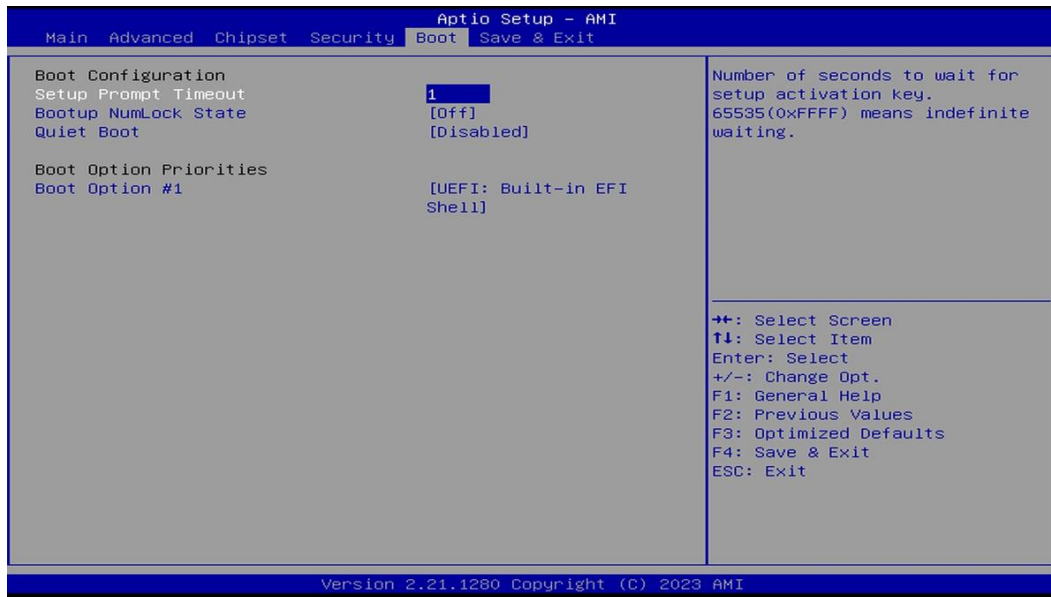

Setup Prompt Timeout

Use this item to set number of seconds to wait for setup activation key.

Bootup NumLock State

Use this item to select keyboard numlock state.

The optional settings are: [On]; [Off].

Quiet Boot

The optional settings are: [Disabled]; [Enabled].

Boot Option Priorities

Boot Option #1

Use this item to sets the system boot order

The optional settings are: [UEFI: Built-in EFI Shell]; [Disabled].

3-11 Save & Exit

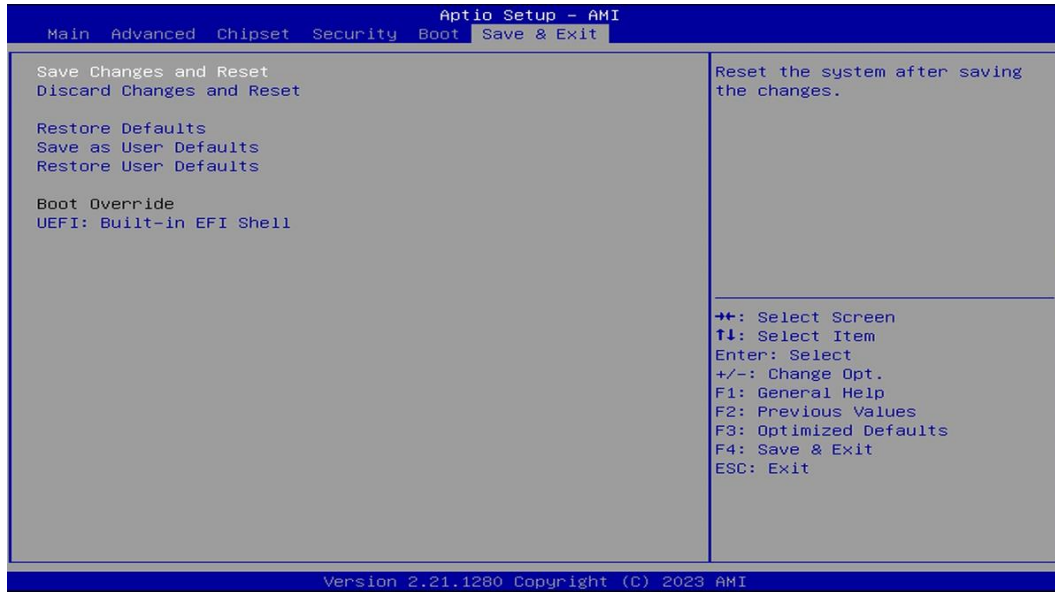

Save Changes and Reset

This item allows user to reset the system after saving the changes.

Discard Changes and Reset

This item allows user to reset the system without saving any changes.

Restore Defaults

Use this item to restore /load default values for all the setup options.

Save as User Defaults

Use this item to save the changes done so far as user defaults.

Restore User Defaults

Use this item to restore defaults to all the setup options.

Boot Override

The available options here are dynamically updated and make system boot to any boot option selected.

UEFI: Built-in EFI Shell

Press this item to select the device as boot disk after save configuration and reset.