

NU95V Series

User's Manual

NO. G03-NU95V-F

Revision: 3.0

Release date: January 10, 2023

Trademark:

- * Specifications and Information contained in this documentation are furnished for information use only, and are subject to change at any time without notice, and should not be construed as a commitment by manufacturer.

Environmental Protection Announcement

Do not dispose this electronic device into the trash while discarding. To minimize pollution and ensure environment protection of mother earth, please recycle.



TABLE OF CONTENT

ENVIRONMENTAL SAFETY INSTRUCTION	iv
USER'S NOTICE	v
MANUAL REVISION INFORMATION	v
ITEM CHECKLIST	v
CHAPTER 1 INTRODUCTION OF THE MOTHERBOARD	
1-1 FEATURE OF MOTHERBOARD	1
1-2 SPECIFICATION	2
1-3 LAYOUT DIAGRAM	3
CHAPTER 2 HARDWARE INSTALLATION	
2-1 JUMPER SETTING.....	7
2-2 CONNECTORS, WAFERS AND HEADERS	9
2-2-1 CONNECTORS	9
2-2-2 WAFERS & HEADERS	13
CHAPTER 3 INTRODUCING BIOS	
3-1 ENTERING SETUP.....	16
3-2 BIOS MENU SCREEN	17
3-3 FUNCTION KEYS	18
3-4 GETTING HELP.....	18
3-5 MEMU BARS.....	19
3-6 MAIN MENU	20
3-7 ADVANCED MENU	21
3-8 CHIPSET MENU	33
3-9 SECURITY MENU	36
3-10 BOOT MENU	39
3-11 SAVE & EXIT MENU	40



Environmental Safety Instruction

- Avoid the dusty, humidity and temperature extremes. Do not place the product in any area where it may become wet.
- 0 to 60 centigrade is the suitable temperature. (The figure comes from the request of the main chipset)
- Generally speaking, dramatic changes in temperature may lead to contact malfunction and crackles due to constant thermal expansion and contraction from the 'welding spots' that connect components and PCB. Computer should go through an adaptive phase before it boots when it is moved from a cold environment to a warmer one to avoid condensation phenomenon. These water drops attached on PCB or the surface of the components can bring about phenomena as minor as computer instability resulted from corrosion and oxidation from components and PCB or as major as short circuit that can burn the components. Suggest starting the computer until the temperature goes up.
- The increasing temperature of the capacitor may decrease the life of computer. Using the close case may decrease the life of other device because the higher temperature in the inner of the case.
- Attention to the heat sink when you over-clocking. The higher temperature may decrease the life of the device and burned the capacitor.

USER'S NOTICE

COPYRIGHT OF THIS MANUAL BELONGS TO THE MANUFACTURER. NO PART OF THIS MANUAL, INCLUDING THE PRODUCTS AND SOFTWARE DESCRIBED IN IT MAY BE REPRODUCED, TRANSMITTED OR TRANSLATED INTO ANY LANGUAGE IN ANY FORM OR BY ANY MEANS WITHOUT WRITTEN PERMISSION OF THE MANUFACTURER.

THIS MANUAL CONTAINS ALL INFORMATION REQUIRED TO USE THIS MOTHER-BOARD SERIES AND WE DO ASSURE THIS MANUAL MEETS USER'S REQUIREMENT BUT WILL CHANGE, CORRECT ANY TIME WITHOUT NOTICE. MANUFACTURER PROVIDES THIS MANUAL "AS IS" WITHOUT WARRANTY OF ANY KIND, AND WILL NOT BE LIABLE FOR ANY INDIRECT, SPECIAL, INCIDENTAL OR CONSEQUENTIAL DAMAGES (INCLUDING DAMAGES FOR LOSS OF PROFIT, LOSS OF BUSINESS, LOSS OF USE OF DATA, INTERRUPTION OF BUSINESS AND THE LIKE).

PRODUCTS AND CORPORATE NAMES APPEARING IN THIS MANUAL MAY OR MAY NOT BE REGISTERED TRADEMARKS OR COPYRIGHTS OF THEIR RESPECTIVE COMPANIES, AND THEY ARE USED ONLY FOR IDENTIFICATION OR EXPLANATION AND TO THE OWNER'S BENEFIT, WITHOUT INTENT TO INFRINGE.

Manual Revision Information

Reversion	Revision History	Date
3.0	Third Edition	January 10, 2023

Item Checklist

- Motherboard
- Cable(s)

Chapter 1

Introduction of the Motherboard

1-1 Feature of Motherboard

- Onboard Intel® 10th Comet Lake i5-10210U Series MCP Processor, with low power consumption never denies high performance
- Support 2* DDR4 2666 MHz SO-DIMM, up to 64GB
- Integrated with 1* Intel® i219LM GbE & 1* Intel® i225V 2.5GbE LAN chips
- 1* M.2 E-key 2230 slot, PCIe1/USB2.0 interface with support for CNVi
- 1* M.2 M-key 2242 slot, SATA interface
- 1* SATAIII device
- 2* HDMI ports & 1* Display port, supports Triple Independent Display
- 1* Line-out/MIC combo
- Support up to 4 * USB 3.2 Gen.2 port (External) & 2 * USB 2.0 port (Internal)
- 1 * COM port supports RS232/422/485
- Support CPU Smart FAN
- Compliance with ErP standard
- Support Watchdog function
- Solution for Digital Signage, Cloud Applications, IoT & Industrial Automation

1-2 Specification

Spec	Description
Design	<ul style="list-style-type: none"> ● NUC form factor; PCB size: 10.1 cm x 10.1 cm
Embedded CPU	<ul style="list-style-type: none"> ● Intel® 10th Comet Lake series MCP CPU,I5-10210U QC, 1.6GHz, 15W <p><i>*Note: CPU model may vary from different IPC options. Please consult your dealer for more information of onboard CPU.</i></p>
Memory Slot	<ul style="list-style-type: none"> ● 2*DDR4 SO-DIMM slot ● Support 2* DDR4 2666MHz SO-DIMM up to 64GB
Expansion Slot	<ul style="list-style-type: none"> ● 1* M.2 E-key,type-2230 slot supports CNVi (M2E) <p><i>*Note:M2E slot maximum current limit is 1A while using 3.3V.</i></p>
Storage	<ul style="list-style-type: none"> ● 1* SATAIII 6Gb/s port ● 1* M.2 M-key,type-2242 SATAIII interface slot (M2M) <p><i>*Note:M2Mslot maximum current limit is 1A while using 3.3V.</i></p>
LAN Chip	<p>Integrated with:</p> <ul style="list-style-type: none"> ● 1* Intel i225V 2.5GbE PCI-E LAN chip of providing 10/100/1000/2500Mbps Ethernet data transfer rate ● 1* Intel i219-LM Gigabit PHY LAN chip of providing 10/100/1000Mbps Ethernet data transfer rate ● Support Fast Ethernet LAN function
Audio Chip	<ul style="list-style-type: none"> ● Integrated with Realtek HD audio chip
BIOS	<ul style="list-style-type: none"> ● AMI 128MB Flash ROM
Rear Panel I/O	<ul style="list-style-type: none"> ● 1* 12V DC-in system power Jack ● 1* Display Port (PS: This function is converted from EDP to DP, only display no audio output) ● 1* HDMI 2.0 port ● 1* HDMI 1.4 port ● 1* 1.0GbE RJ-45 LAN port & 2.5GbE RJ-45 LAN port ● 2* USB 3.2 (Gen.2) port
Front Panel I/O	<ul style="list-style-type: none"> ● 1* Serial port (COM supports RS232/422/485 function) ● 2* USB 3.2 (Gen.2) port ● 1* Audio Line-Out & MIC combo jack
Internal I/O	<ul style="list-style-type: none"> ● 1* SATA Power connector ● 1* CPU FAN wafer (on the backside)

- 1* JW_FP front panel header
- 1* GPIO header
- 1* 9-Pin USB 2.0/1.1 header for 2* USB 2.0/1.1 ports

***Note:** Many PCs now include XHCI USB controllers which allow for the support of USB 3.0 and higher USB speeds. This inclusion of XHCI controllers has lessened the need for EHCI USB controllers within platforms. However, legacy operating systems (OS) may not natively recognize XHCI controllers. You might need to pre-install XHCI driver while desiring to install a non-XHCI OS (ex. Windows* 7) on Intel platforms which do not include EHCI controllers. Please contact your representative for more details.

1-3 Layout Diagram

Rear IO Panel Diagram:

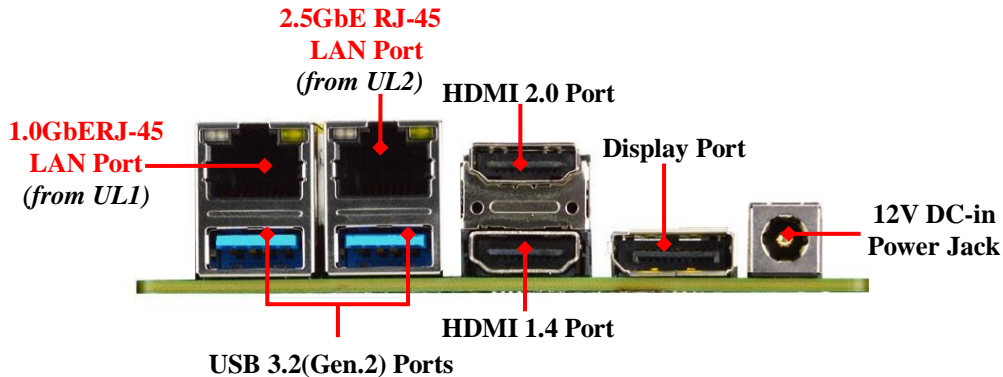

Front IO Panel Diagram:

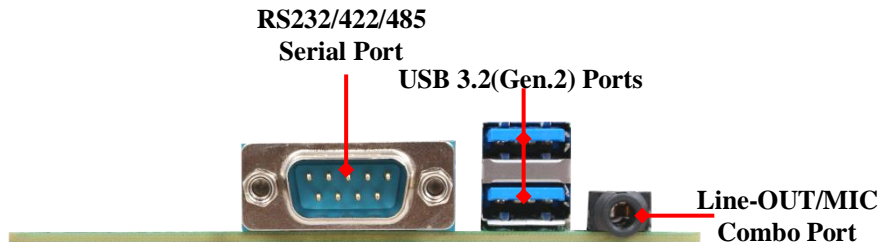

Internal Diagram-Front Side:

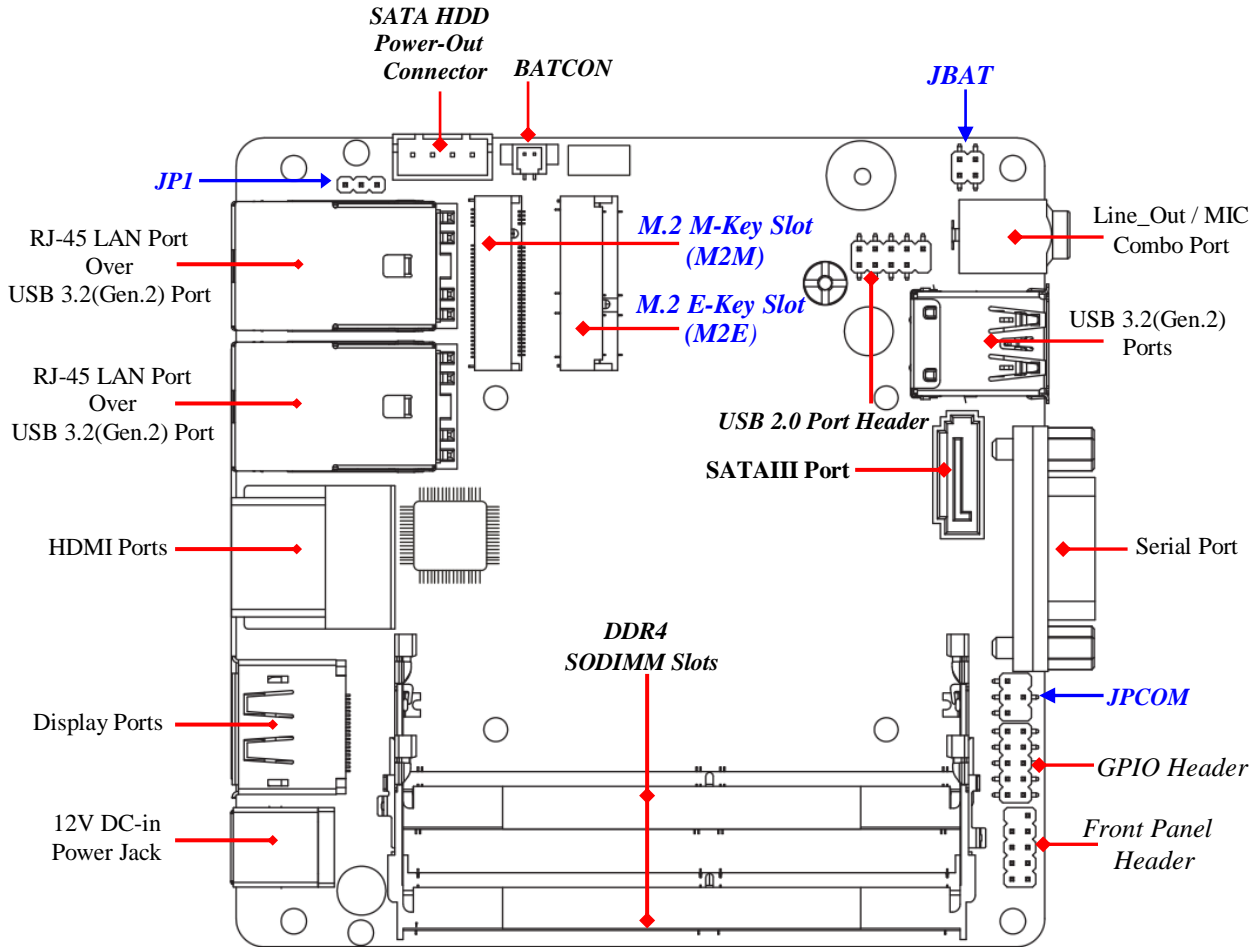

Internal Diagram-Back Side:

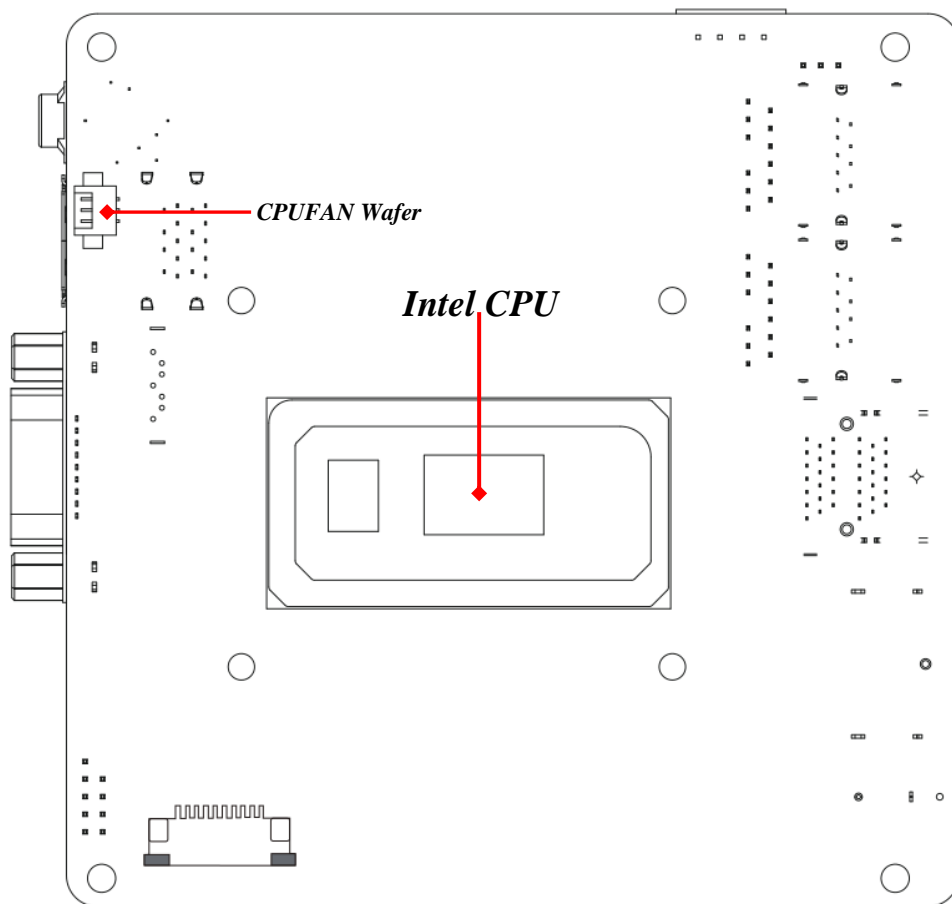

Connectors

P/N	Name
UL1	Top: 1.0GbE RJ-45 LAN Port Connector Bottom: USB 3.2 (Gen.2) Port Connector
UL2	Top: 2.5GbE RJ-45 LAN Port Connector Bottom: USB 3.2 (Gen.2) Port Connector
HDMI1	Top: HDMI 2.0 Connector Bottom: HDMI 1.4 Connector
DP	Display Port Connector
DC_IN	12V DC-in System Power Jack
COM	RS232/422/485 Serial Port Connector
USB30	USB 3.2 (Gen.2) Port Connector
AUDIO	Line-Out/MIC Combo Connector
SATA	SATAIII Port Connector
SATAPW	SATA Power out Connector

Headers & Wafers

P/N	Name	Description	Pitch
JW_FP	Front Panel Header	9-pin Block	2.0mm
GPIO_CON	GPIO Header	10-pin Block	2.0mm
FP_USB1	USB 2.0 Port Header	9-pin Block	2.0mm
CPUFAN (backside)	CPUFAN Wafer	3-pin Block	1.25mm

Jumper

P/N	Name	Description	Pitch
JPCOM	COM Port Pin9 Function Select	4-Pin Block	2.0mm
JBAT	Pin (1-2): Clear CMOS RAM Setting Pin (3-4): Flash Descriptor Security Override	4-Pin Block	2.0mm
JP1	ATX Mode & AT Mode Select	3-Pin Block	2.0mm

Chapter 2

Hardware Installation

2-1 Jumper Setting

JPCOM (4-pin): COM Port Pin9 Function Select

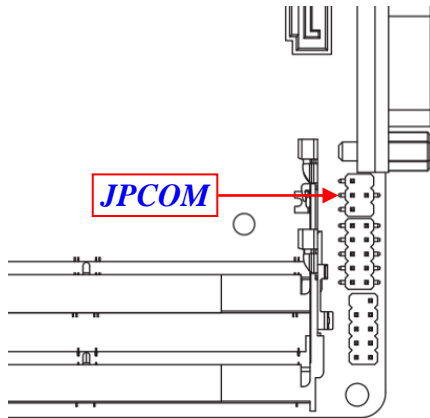

JPCOM 1 → COM Port Pin9 Function Select

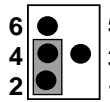

2-4 Closed:
RI=RS232;

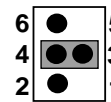

3-4 Closed:
RI= +5V;

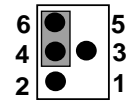

6-4 Closed:
RI = +12V.

***Note:** Maximum current limit is 500mA while using 5V or 12V.

Pin (1-2) of JBAT (4-pin): Clear CMOS RAM Setting

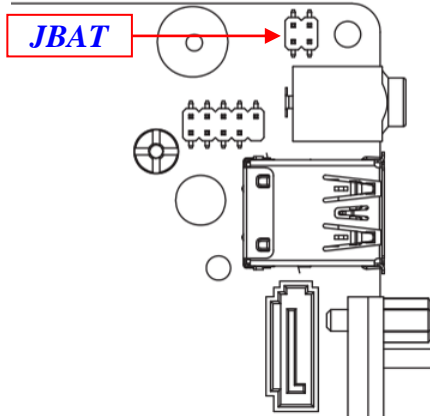

PIN(1-2) of JBAT: Clear CMOS

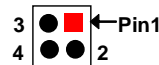

1-2 Open: Normal(Default);

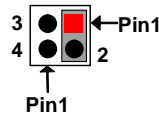

1-2 Closed: Clear CMOS (One Touch).

Pin (3-4) of JBAT (4-pin): Flash Descriptor Security Override

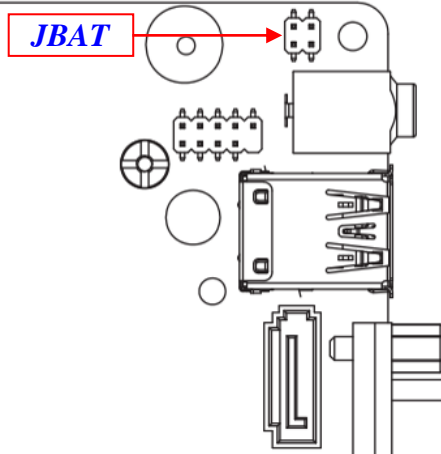

PIN(3-4) of JBAT: Flash Override

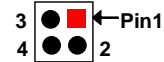

3-4 Open: Enable Security Measures in the Flash Descriptor(Default);

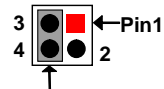

3-4 Closed: Disable Security Measures in the Flash Descriptor(Override).

JP1 (3-pin): ATX Mode/ AT Mode Select

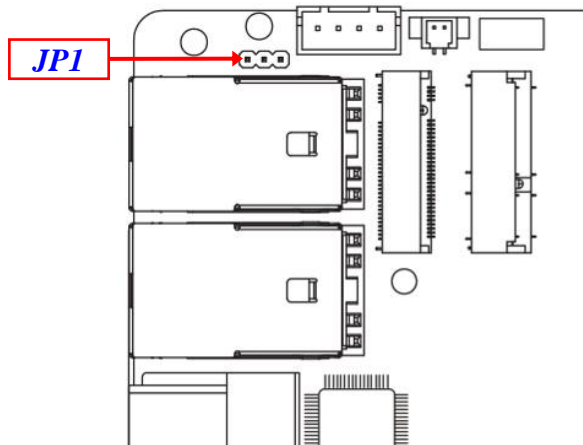

JP1 → ATX/AT Mode Select

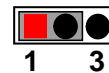

1-2 Closed: ATX Mode Selected;

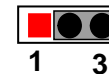

2-3 Closed: AT Mode Selected.

ATX Mode Selected: Press power button to power on after power input ready;
AT Mode Selected: Directly power on as power input ready.

2-2 Connectors, Wafers and Headers





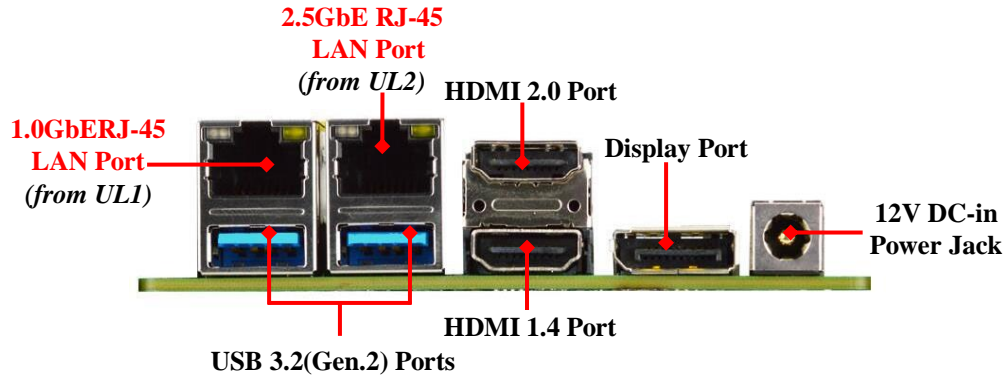

2-2-1 Connectors

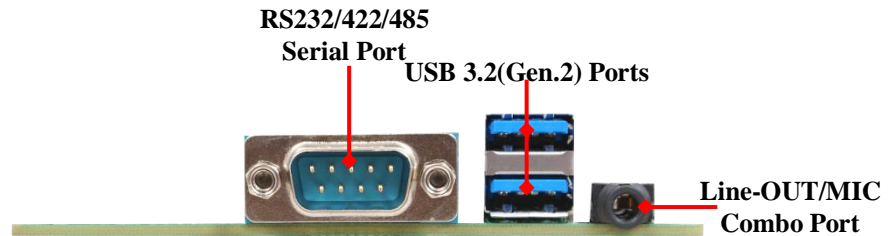
Rear IO Panel Diagram:



Front IO Panel Diagram:



Icon	Name	Function
	Power Connector	12V DC-in system power connector For user to connect compatible power adapter to provide power supply for the system.
	Display Port	To the system to corresponding display device with compatible display port cable.
	HDMI Port	To connect display device that support HDMI specification. Top: 1* HDMI 2.0 port Bottom: 1* HDMI 1.4 port
	RJ-45 LAN Port	This connector is standard RJ-45 LAN jack for Network connection.
	USB 3.2 (Gen.2) Port	To connect USB keyboard, mouse or other devices compatible with USB 3.2 (Gen.2) specification. Ports support up to 10Gbps data transfer rate.
	Line-Out/MIC Combo Connector	This connector can functions as audio Line-Out jack and MIC jack with compatible cables & devices.
	RS232/422/485 Serial Port	Mainly for user to connect external MODEM or other devices that supports Serial Communications Interface.

***Note:** 1. Maximum current limit for USB ports:

※ **UL1+UL2 total is 1.5A.**

※ **USB30+FP_USB1 (header) total is 1.5A.**

2. **DP port** is converted from EDP, only display function, not support audio output.

(1) COM (9-pin Block): RS232/422/485 Serial Port

COM port can function as RS232/422/485 port. In normal settings COM functions as RS232 port. With compatible COM cable they can function as RS422 or RS 485 port. User also needs to go to BIOS to set '**Transmission Mode Select**' for COM (refer to Page 26) at first, before using specialized cable to connect different pins of this port.

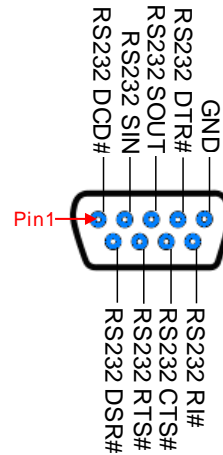
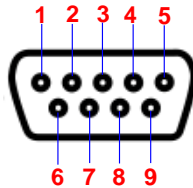

For RS232 Mode

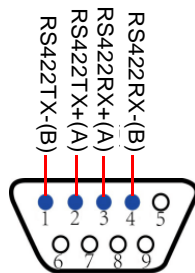

For RS422 Mode

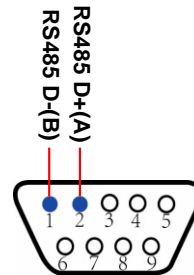

For RS485 Mode

(2) SATA (7-pin Block): SATAIII Port connector

The board comes with a SATAIII port that supports 6GB/s transfer rate.

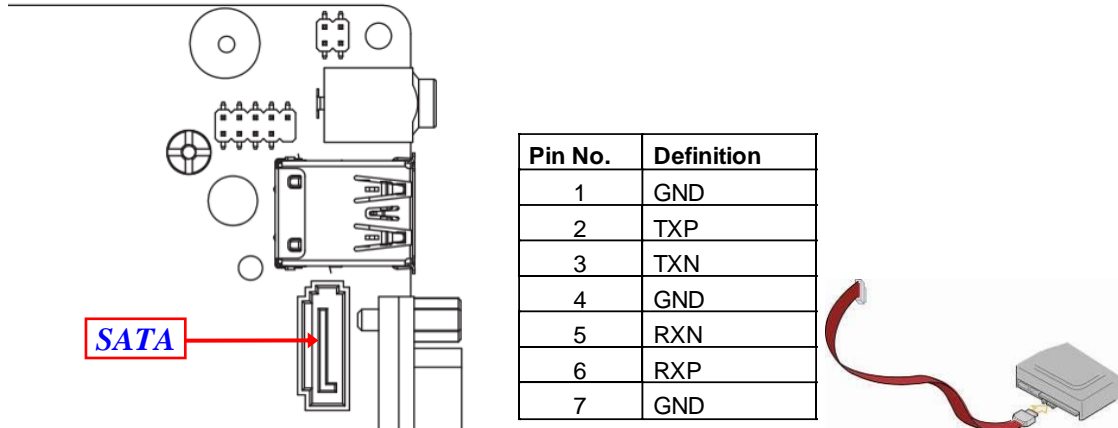

(3) SATAPW (4-pin): SATA HDD Power-Out Connector

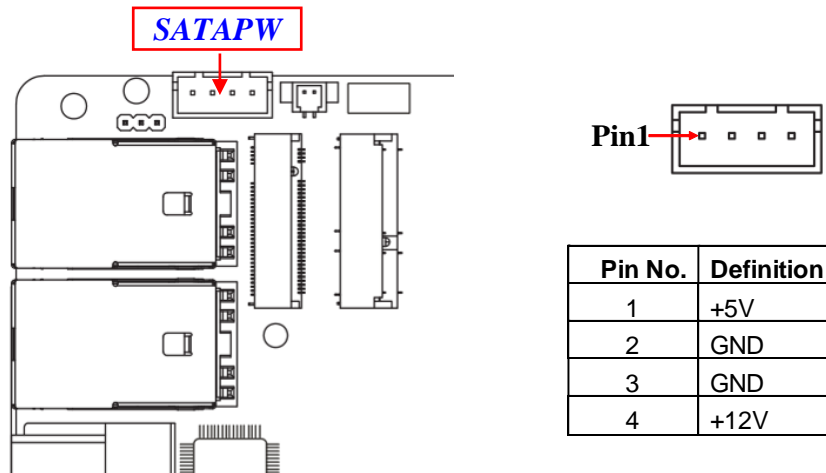

***Note:** Maximum current limit is **2A** while using 5V or 12V working voltage.

(4) BATCON (2-pin): Battery Connector

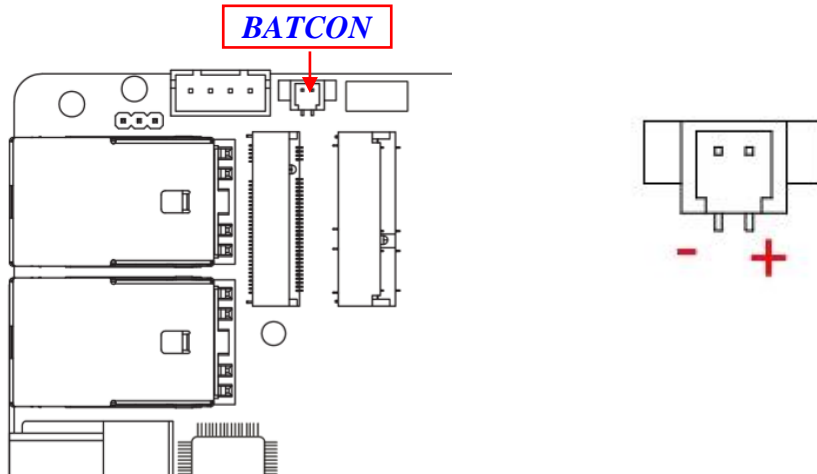

2-2-2 Wafers & Headers

(1) JW_FP1 (9-pin): Front Panel Header

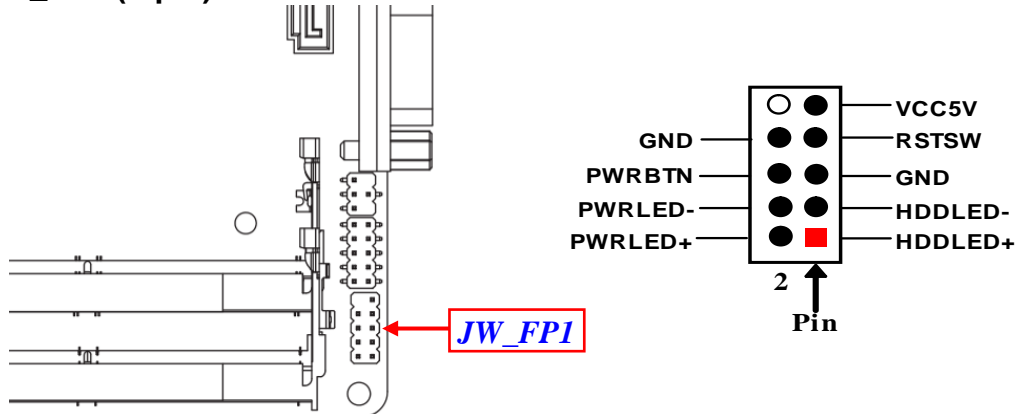

***Note:** Maximum current limit is **1A** while using 5V working voltage.

(2) GPIO_CON (10-pin): GPIO Header

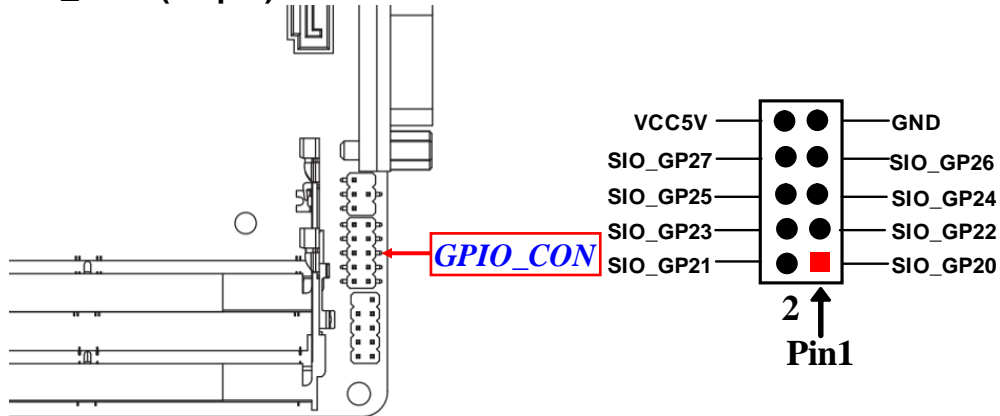

***Note:** Maximum current limit is 1A while using 5V working voltage.

(3) FP_USB1(9-pin): USB 2.0 Port Header

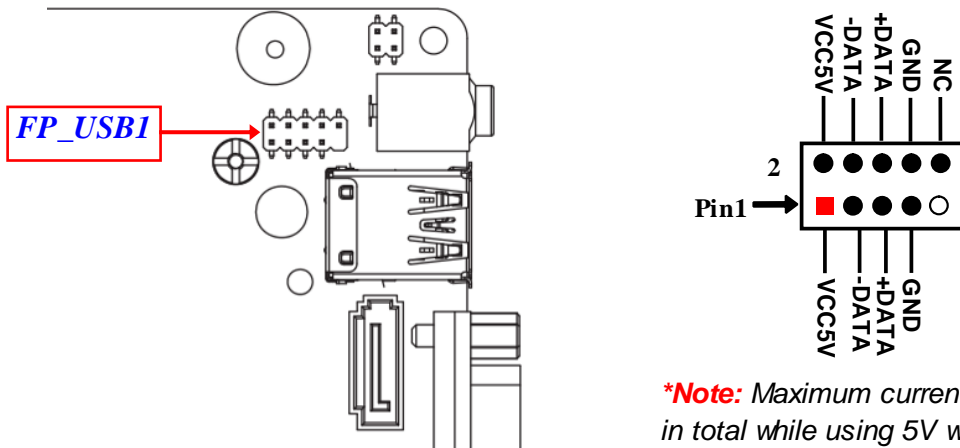

***Note:** Maximum current limit is 1.5A in total while using 5V working voltage.

(4) CPUFAN (3-pin): CPUFAN Wafer

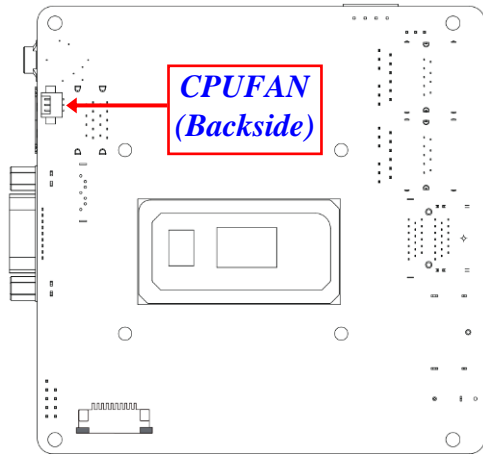

Pin1

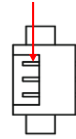

Pin No.	Definition
1	FAN_OUT
2	GND
3	Fan Detect

***Note:** This is a 5V DC FAN and deliver up to 0.6A output current.

Chapter 3

Introducing BIOS

Notice! The BIOS options in this manual are for reference only. Different configurations may lead to difference in BIOS screen and BIOS screens in manuals are usually the first BIOS version when the board is released and may be different from your purchased motherboard. Users are welcome to download the latest BIOS version form our official website.

The BIOS is a program located on a Flash Memory on the motherboard. This program is a bridge between motherboard and operating system. When you start the computer, the BIOS program will gain control. The BIOS first operates an auto-diagnostic test called POST (power on self test) for all the necessary hardware, it detects the entire hardware device and configures the parameters of the hardware synchronization. Only when these tasks are completed done it gives up control of the computer to operating system (OS). Since the BIOS is the only channel for hardware and software to communicate, it is the key factor for system stability, and in ensuring that your system performance as its best.

3-1 Entering Setup

Power on the computer and by pressing immediately allows you to enter Setup. If the message disappears before your respond and you still wish to enter Setup, restart the system to try again by turning it OFF then ON or pressing the “RESET” button on the system case. You may also restart by simultaneously pressing <Ctrl>, <Alt> and <Delete> keys. If you do not press the keys at the correct time and the system does not boot, an error message will be displayed and you will again be asked to

Press **** to enter Setup; press **< F7>** to enter pop-up Boot menu.

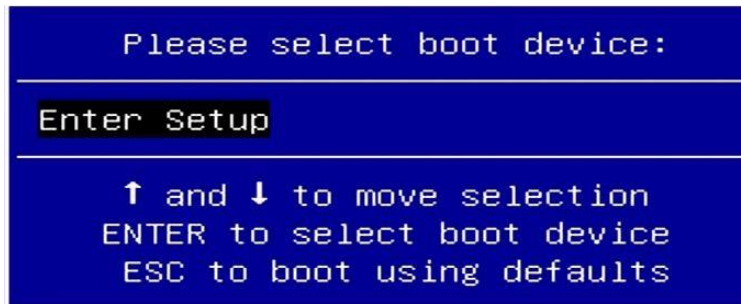

BIOS Boot Menu Screen (boot device options please refer to actual configuration)

3-2 BIOS Menu Screen

The following diagram show a general BIOS menu screen:

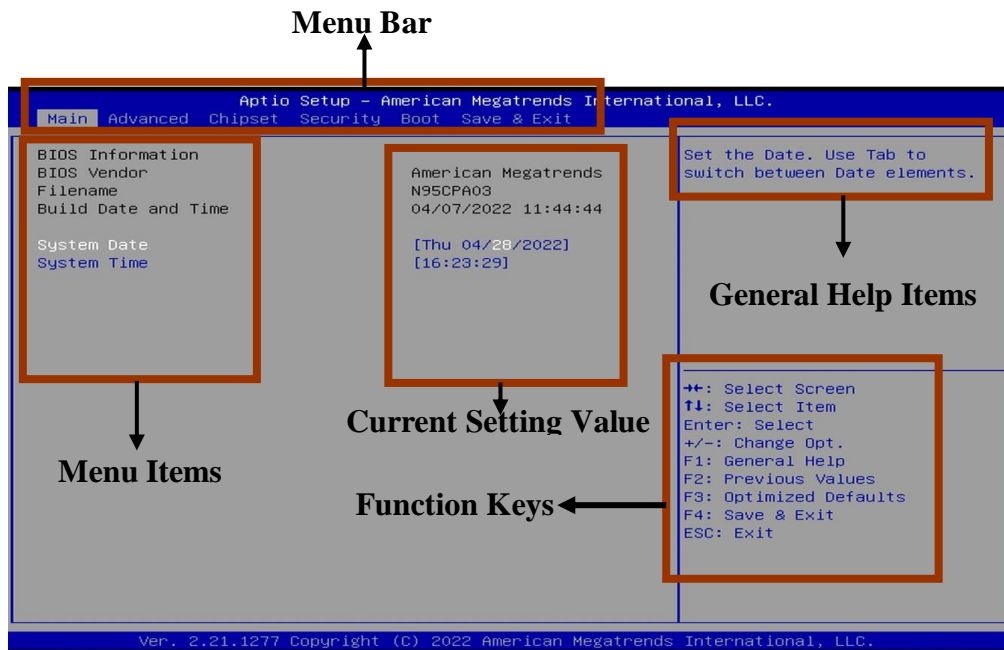

3-3 Function Keys

In the above BIOS Setup main menu of, you can see several options. We will explain these options step by step in the following pages of this chapter, but let us first see a short description of the function keys you may use here:

- Press ←→ (left, right) to select screen.
- Press ↑↓ (up, down) to choose, in the main menu, the option you want to confirm or to modify.
- Press <Enter> to select.
- Press <+>/<-> keys when you want to modify the BIOS parameters for the active option.
- [F1]: General help.
- [F2]: Previous values.
- [F3]: Optimized defaults.
- [F4]: Save & Exit.
- Press <Esc> to exit from BIOS Setup.

3-4 Getting Help

Main Menu

The on-line description of the highlighted setup function is displayed at the top right corner the screen.

Status Page Setup Menu/Option Page Setup Menu

Press **【F1】** to pop up a small help window that describes the appropriate keys to use and the possible selections for the highlighted item. To exit the Help Window, press **<Esc>**.

3-5 Menu Bars

There are six menu bars on top of BIOS screen:

Main	To change system basic configuration
Advanced	To change system advanced configuration
Chipset	To change chipset configuration
Security	Password settings
Boot	To change boot settings
Save & Exit	Save setting, loading and exit options.

User can press the right or left arrow key on the keyboard to switch from menu bar. The selected one is highlighted.

3-6 Main Menu

Main menu screen includes some basic system information. Highlight the item and then use the <+> or <-> and numerical keyboard keys to select the value you want in each item.

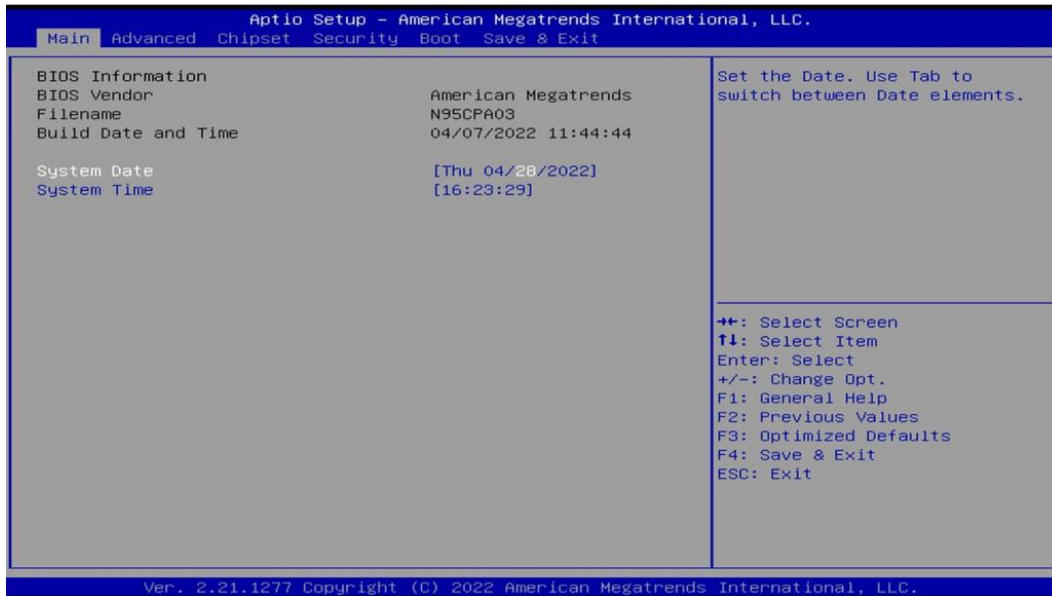

System Date

Set the date. Please use [Tab] to switch between date elements.

System Time

Set the time. Please use [Tab] to switch between time elements.

3-7 Advanced Menu

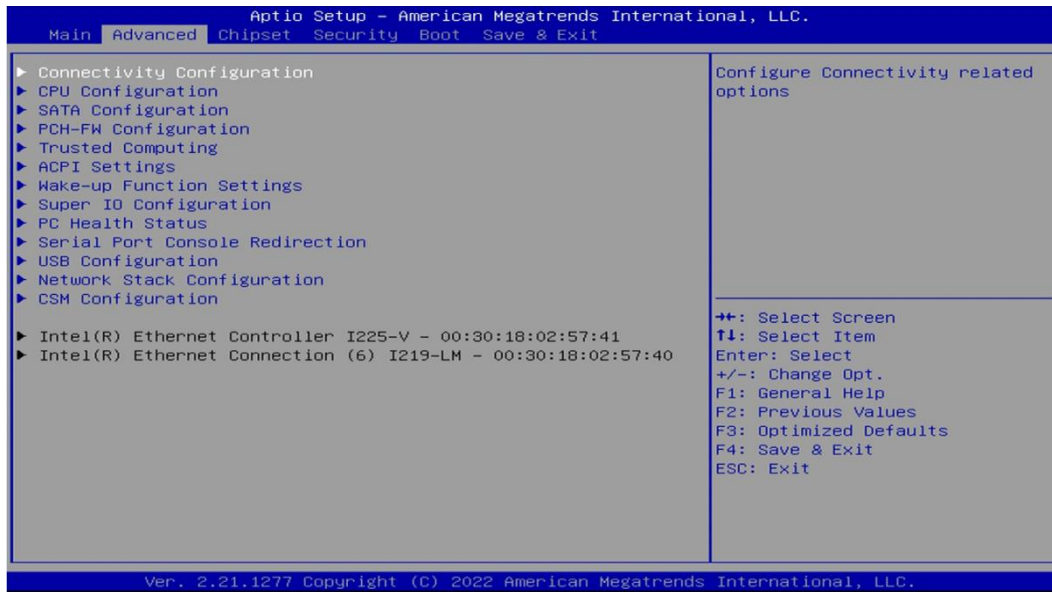

▶ **Connectivity Configuration**

Use this item to configure Connectivity related options. Press [Enter] to make settings for the following sub-items:

CNVi present

CNVi Configuration

CNVi Mode

This option configures Connectivity.

The optional settings: [Disabled Integrated]; [Auto Detection].

[Auto Detection] means that if Discrete solution is discovered it will be enabled by default. Otherwise Integrated solution (CNVi) will be enabled;

[Disabled Integrated] disables Integrated Solution.

▶ **CPU Configuration**

Press [Enter] to view current CPU configuration and make settings for the following

sub-items:

Hyper-Threading

Use this item to enable or disable Hyper-Threading Technology.

The optional settings: [Disabled]; [Enabled].

Intel (VMX) Virtualization Technology

The optional settings: [Disabled]; [Enabled].

When set as [Enabled], a VMM can utilize the additional hardware capabilities provided by Vanderpool Technology.

Intel(R) SpeedStep(tm)

This item allows more than two frequency ranges to be supported.

The optional settings: [Disabled]; [Enabled].

C states

Use this item to enable or disable CPU Power Management. When set as [Enabled], it allows CPU to go to C states when it's not 100% utilized.

The optional settings: [Disabled]; [Enabled].

▶ **SATA Configuration**

Press [Enter] to make settings for the following sub-items:

SATA Configuration

SATA Controller(s)

Use this item to enable or disable SATA Device.

The optional settings: [Enabled]; [Disabled].

When set as [Enabled], the following items shall appear:

SATA Mode Selection

Use this item to determines how SATA controller(s) operate

The optional settings: [AHCI]; [RAID]

M.2

Port

Use this item to enable or disable SATA Port.

The optional settings: [Disabled]; [Enabled].

SATA

Port

Use this item to enable or disable SATA Port.

The optional settings: [Disabled]; [Enabled].

Hot Plug

Use this item to designate this port as Hot Pluggable.

The optional settings: [Disabled]; [Enabled].

▶ **PCH-FW Configuration**

Use this item to configure management engine technology parameters

Press [Enter] to view Management Engine Technology Parameters and make settings in the following sub-item:

ME Firmware Version

ME Firmware Mode

TPM Device Selection

Use this item to select TPM Device.

The optional settings: [dTPM]; [PTT].

[PTT]: Enable PTT in SkuMgr; [dTPM]: Disable PTT in SkuMgr.

Warning! PTT/dTPM will be disabled and all data saved on it will be lost.

▶ **Firmware Update Configuration**

Press [Enter] to make settings for '**Me FW Image Re-Flash**'.

Me FW Image Re-Flash

Use this item to enable or disable Me FW Image Re-Flash function.

The optional settings: [Disabled]; [Enabled].

*** Note:** In the case that user needs to update Me firmware, user should set '**Me FW Image Re-Flash**' as [**Enabled**], save the settings and exit. The system will turn off and reboot after 4 seconds. If the user goes to BIOS screen again will find this item is set again as [**Disabled**], but user can still re-flash to update firmware next time.

▶ **Trusted Computing**

Press [Enter] to view current status information, or make further settings in the following sub-items:

Configuration

Security Device Support

Use this item to enable or disable BIOS support for security device. O.S. will not show Security Device. TCG EFI protocol and INT1A interface will not be available. The optional settings: [Disabled]; [Enabled].

No Security Device Found

▶ **ACPI Settings**

Press [Enter] to make settings for the following sub-items:

ACPI Settings

ACPI Sleep State

Use this item to select the highest ACPI sleep state the system will enter when the SUSPEND button is pressed.

The optional settings: [Suspend Disabled]; [S3 (Suspend to RAM)].

▶ **Wake-up Function Settings**

Press [Enter] to make settings for the following sub-items:

Wake-up System With Fixed Time

Use this item to enable or disable System wake on alarm event.

The optional settings: [Disabled]; [Enabled].

When set as [Enabled], the following items shall appear:

Wake-up Hour

Use this item to select 0-23. For example enter 3 for 3am and 15 for 3pm.

Wake-up Minute

Use this item to select 0-59.

Wake-up Second

Use this item to select 0-59.

When set as [Disabled], the following items shall appear:

Wake-up System with Dynamic Time

Use this item to enable or disable System wake on alarm event.

System will wake on the current time + Increase minute(s).

The optional settings: [Disabled]; [Enabled].

When set as [Enabled], system will wake on the current time + increased

minute(s).

Wake-up Minute Increase

Use this item to select 1-60.

USB S3/S4 Wake-up

Use this item to enable or disable USB wake-up from S3/S4 state.

The optional settings: [Enabled]; [Disabled].

***Note:** *This function is supported when 'ERP Support' is set as [Disabled].*

USB S5 Power

Use this item to enable or disable USB Power after System Shutdown.

The optional settings: [Disabled]; [Enabled].

***Note:** *This function is supported when 'ERP Support' is set as [Disabled].*

▶ **Super IO Configuration**

Press [Enter] to make settings for the following sub-items:

Super IO Configuration

ERP Support

Use this item to select Energy-Related Products function. This item should be set as [Disabled] if you wish to have all active wake-up functions.

The optional settings: [Disabled]; [Auto].

▶ **Serial Port 1 Configuration**

Press [Enter] to make settings for the following items:

Serial Port 1 Configuration

Serial Port

Use this item to enable or disable Serial Port (COM).

The optional settings: [Disabled]; [Enabled].

When set as [Enabled], user can make further settings in the following items:

Device Settings

Change Settings

Use this item to select an optimal setting for Super IO Device.

The optional settings: [IO=3F8h; IRQ=4;]; [IO=3F8h; IRQ=3,4,5,7,10,11;];

[IO=2F8h; IRQ=3,4,5,7,10,11;]; [IO=3E8h; IRQ=3,4,5,7,10,11;]; [IO=2E8h;

IRQ=3,4,5,7,10,11;].

Transmission Mode Select

The optional settings: [RS422]; [RS232]; [RS485].

Mode Speed Select

Use this item to select RS232/RS422/RS485 Speed.

The optional settings: [RS232/RS422/RS485=250Kbps]; [RS232=1Mbps, RS422/RS485=10Mbps].

Serial Port FIFO Mode

The optional settings:[16-Byte FIFO]; [32-Byte FIFO] [64-Byte FIFO]; [128-Byte FIFO].

WatchDog Reset Timer

Use this item to enable or disable WDT reset function.

The optional settings: [Disabled]; [Enabled].

When set as [Enabled], the following sub-items shall appear:

WatchDog Reset Timer Value

User can select a value in the range of [4] to [255] seconds when 'WatchDog Reset Timer Unit' set as [Sec]; or in the range of [4] to [255] minutes when 'WatchDog Reset Timer Unit' set as [Min].

WatchDog Reset Timer Unit

The optional settings: [Sec.]; [Min.].

WatchDog Wake-up Timer in ERP

Use this item to support WDT Wake-up while ERP function is Auto

The optional settings: [Disabled]; [Enabled]

When set as [Enabled], the following sub-items shall appear:

WatchDog Timer Value in ERP

Use this item to Range: 10-4095 seconds, or 1-4095 minutes.

WatchDog Timer Unit in ERP

The optional settings: [Sec.]; [Min.].

ATX Power Emulate AT Power

This item support Emulate AT power function, MB power On/Off control by power supply. Use needs to select 'AT or ATX Mode' on MB jumper at first (*refer to JP1*

jumper setting for AT-MODE setting Pin 1&2 of for ATX Mode & Pin 2&3 of AT Mode Select).

▶ **PC Health Status**

Press [Enter] to view current hardware health status, make further settings in 'SmartFAN Configuration' and set value in 'Shutdown Temperature'.

▶ **SmartFAN Configuration (Option)**

Press [Enter] to make settings for 'SmartFan Configuration':

SmartFAN Configuration (Option)

CPUFAN Smart Mode

The optional settings: [Disabled]; [Enabled].

When set as [Enabled], the following sub-items shall appear:

CPUFAN Full-Speed Temperature

Use this item to set CPUFAN full speed temperature. Fan will run at full speed when above this pre-set temperature.

CPUFAN Full-Speed Duty

Use this item to set CPUFAN full-speed duty. Fan will run at full speed when above this pre-set duty.

CPUFAN Idle-Speed Temperature

Use this item to set CPUFAN idle speed temperature. Fan will run at idle speed when below this pre-set temperature.

CPUFAN Idle-Speed Duty

Use this item to set CPUFAN idle speed duty. Fan will run at idle speed when below this pre-set duty.

Shutdown Temperature

The optional settings: [Disabled]; [70°C/158°F]; [75°C/167°F]; [80°C/176°F]; [85°C/185°F]; [90°C/194°F]

▶ **Serial Port Console Redirection**

COM1

Console Redirection

Use this item to enable or disable COM1 Console Redirection.

The optional settings: [Disabled]; [Enabled].

When set as [Enabled], user can make further settings in the following items:

▶ **Console Redirection Settings**

The settings specify how the host computer and the remote computer (which the user is using) will exchange data. Both computers should have the same or compatible settings.

Press [Enter] to make settings for the following sub-items.

COM1

Console Redirection Settings

Terminal Type

The optional settings: [VT100]; [VT100+]; [VT-UTF8]; [ANSI].

Emulation: **[ANSI]**: Extended ASCII char set; **[VT100]**: ASCII char set;

[VT100+]: Extends VT100 to support color, function keys, etc.; **[VT-UTF8]**:

Uses UTF8 encoding to map Unicode chars onto 1 or more bytes.

Bits per second

Use this item to select serial port transmission speed. The speed must be matched on the other side. Long or noisy lines may require lower speeds.

The optional settings: [9600]; [19200]; [38400]; [57600]; [115200].

Data Bits

The optional settings: [7]; [8].

Parity

A parity bit can be sent with the data bits to detect some transmission errors.

The optional settings: [None]; [Even]; [Odd]; [Mark]; [Space].

[Even]: parity bit is 0 if the num of 1's in the data bits is even;

[Odd]: parity bit is 0 if num of 1's in the data bits is odd;

[Mark]: parity bit is always 1;

[Space]: parity bit is always 0;

[Mark] and **[Space]**: parity do not allow for error detection.

Stop Bits

Stop bits indicate the end of a serial data packet. (A start bit indicates the beginning). The standard setting is 1 stop bit. Communication with slow

devices may require more than 1 stop bit.

The optional settings: [1]; [2].

Flow Control

Flow control can prevent data loss from buffer overflow. When sending data, if the receiving buffers are full, a “stop” signal can be sent to stop the data flow. Once the buffers are empty, a “start” signal can be sent to re-start the flow. Hardware flow control uses two wires to send start/stop signals.

The optional settings: [None]; [Hardware RTS/CTS].

VT-UTF8 Combo Key Support

Use this item to enable VT-UTF8 Combination Key Support for ANSI/VT100 terminals.

The optional settings: [Disabled]; [Enabled].

Recorder Mode

With this mode enable only text will be sent. This is to capture Terminal data.

The optional settings: [Disabled]; [Enabled].

Resolution 100x31

Use this item to enable or disable extended terminal resolution.

The optional settings: [Disabled]; [Enabled].

Putty KeyPad

Use this item to select FunctionKey and KeyPad on Putty.

The optional settings: [VT100]; [LINUX]; [XTERMR6]; [SCO]; [ESCN]; [VT400].

Serial Port for Out-of-Band Management/

Windows Emergency Management Services (EMS)

Console Redirection EMS

Use this item to enable or disable Console Redirection.

The optional settings: [Disabled]; [Enabled].

When set as [Enabled], the following sub-items shall appear:

► Console Redirection Settings

The settings specify how the host computer and the remote computer (which the user is using) will exchange data. Both computers should have the same or

compatible settings.

Press [Enter] to make settings for the following items:

Out-of-Band Mgmt Port

Terminal Type EMS

The optional settings: [VT100]; [VT100+]; [VT-UTF8]; [ANSI].

[VT-UTF8] is the preferred terminal type for out-of-band management. The next best choice is [VT100+] and then [VT100]. See above, in Console Redirection Settings page, for more help with Terminal Type/Emulation.

Bits per second EMS

Use this item to select serial port transmission speed. The speed must be matched on the other side. Long or noisy lines may require lower speeds.

The optional settings: [9600]; [19200]; [57600]; [115200].

Flow Control EMS

Flow control can prevent data loss from buffer overflow. When sending data, if the receiving buffers are full, a “stop” signal can be sent to stop the data flow. Once the buffers are empty, a “start” signal can be sent to re-start the flow. Hardware flow control uses two wires to send start/stop signals.

The optional settings: [None]; [Hardware RTS/CTS]; [Software Xon/Xoff].

Data Bits EMS

The default setting is: [8].

**This item may or may not show up, depending on different configuration.*

Parity EMS

The default setting is: [None].

**This item may or may not show up, depending on different configuration.*

Stop Bits EMS

The default setting is: [1].

**This item may or may not show up, depending on different configuration.*

▶ **USB Configuration**

Press [Enter] to make settings for the following sub-items:

USB Configuration

Legacy USB Support

Use this item to Enables Legacy USB support AUTO option disables legacy support if no USB devices are connected. DISABLE option will keep USB devices available only EFI applications

The optional settings: [Disabled]; [Enabled]; [Auto]

XHCI Hand-off

This is a workaround for Oses without XHCI hand-off support. The XHCI ownership change should be claimed by XHCI driver.

The optional settings: [Enabled]; [Disabled].

USB Mass Storage Driver Support

Use this item to enable or disable USB mass storage driver support.

The optional settings: [Disabled]; [Enabled].

USB hardware delays and time-outs:

USB transfer time-out

Use this item to set the time-out value for Control, Bulk, and Interrupt transfers.

The optional settings: [1 sec]; [5 sec]; [10 sec]; [20 sec].

Device reset time-out

Use this item to set USB mass storage device Start Unit command time-out.

The optional settings: [10 sec]; [20 sec]; [30 sec]; [40 sec].

Device power-up delay

Use this item to set maximum time the device will take before it properly reports itself to the host controller. 'Auto' uses default value: for a root port it is 100 ms, for a hub port the delay is taken from hub descriptor.

The optional settings: [Auto]; [Manual].

Select **[Manual]** you can set value for the following sub-item: '**Device power-up delay in seconds**', the delay range in from 1 to 40 seconds, in one second increments.

▶ **Network Stack Configuration**

Press [Enter] to go to '**Network Stack**' screen to make further settings.

Network Stack

Use this item to enable or disable UEFI Network Stack.

The optional settings: [Disabled]; [Enabled].

When set as [Enabled], the following sub-items shall appear:

IPv4 PXE Support

Use this item to enable IPv4 PXE boot support. When set as [Disabled], IPv4 boot support will not be available.

The optional settings: [Disabled]; [Enabled].

IPv6 PXE Support

Use this item to enable IPv6 PXE boot support. When set as [Disabled], IPv6 boot support will not be available.

The optional settings: [Disabled]; [Enabled].

PXE boot wait time

Use this item to set wait time to press [ESC] key to abort the PXE boot.

Use either [+] / [-] or numeric keys to set the value.

Media detect count

Use this item to set number of times presence of media will be checked.

Use either [+] / [-] or numeric keys to set the value.

▶ **CSM Configuration**

Press [Enter] to make settings for the following sub-items:

Compatibility Support Module Configuration

CSM Support

Use this item to enable/disable CSM Support.

The optional settings: [Disabled]; [Enabled].

When set as [Enabled], the following sub-items shall appear:

Option ROM execution

Network

Use this item to controls the execution of Network OpROM

The optional settings: [Do not launch]; [UEFI]; [Legacy].

Storage

Use this item to controls the execution of UEFI and Legacy Storage OpROM

The optional settings: [Do not launch]; [UEFI]; [Legacy].

Other PCI devices

Use this item to determine OpROM execution policy for devices other than Network, Storage, or Video

The optional settings: [Do not launch]; [UEFI]; [Legacy].

- ▶ **Intel(R) Ethernet Controller I225-V - XX:XX:XX:XX:XX:XX**
This item shows current network brief information.
- ▶ **Intel(R) Ethernet Connection (6) I219-LM - XX:XX:XX:XX:XX:XX**
This item shows current network brief information.

3-8 Chipset Menu

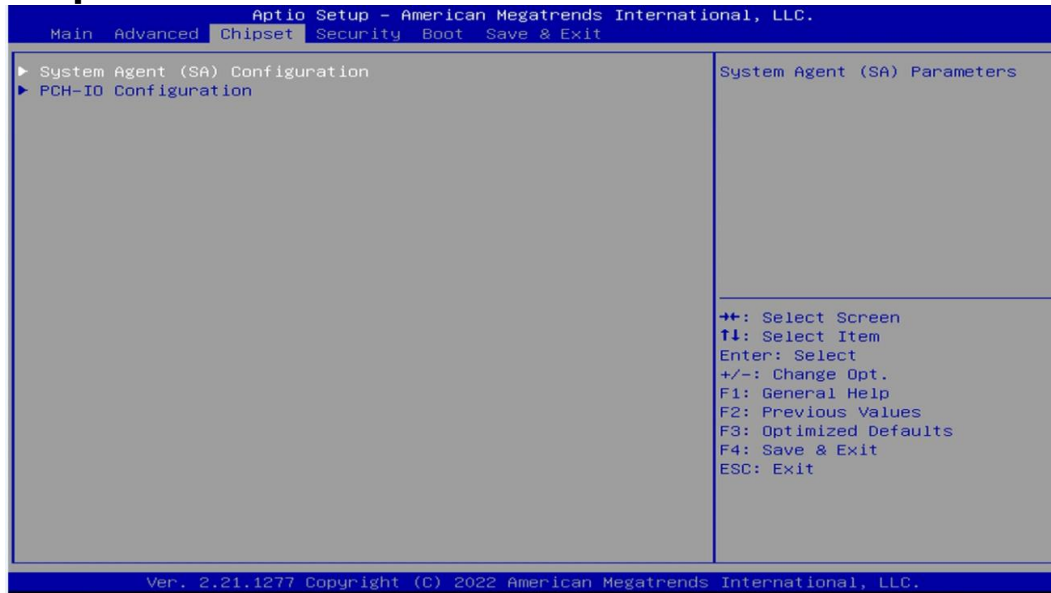

- ▶ **System Agent (SA) Configuration**
Press [Enter] to make settings for the following sub-items:
System Agent (SA) Configuration
VT-d

► **Memory Configuration**

Press [Enter] to view brief information for the working memory module.

► **Graphics Configuration**

Press [Enter] to make further settings for Graphics Configuration.

Graphics Configuration

Primary IGFX Boot Display

Select the Video Device which will be activated during POST. This has no effect if external graphics present. Secondary boot display selection will appear based on your selection. VGA modes will be supported only on primary display.

The optional settings: [VBIOS Default]; [HDMI1]; [HDMI2]; [DP].

***Note:** In the case that the '**Primary IGFX Boot Display**' is select as [HDMI1], [HDMI2], or [DP], user can make further settings in '**Secondary IGFX Boot Display**':

Secondary IGFX Boot Display

Use this item to select the Secondary Display Device.

The optional settings: [Disabled]; [HDMI1]; [HDMI2]; [DP].

Aperture Size

Use this item to select the Aperture Size

The optional settings: [128MB]; [256MB]; [512MB]; [1024MB].

Note: Above 4GB MMIO BIOS assignment is automatically enabled when selecting 2048MB aperture. To use this feature, please disable CSM Support

DVMT Pre- Allocated

Use this item to select DVMT 5.0 Pre-Allocated (Fixed) Graphics Memory size used by the Internal Graphics Device.

The optional settings: [0M]; [32M]; [64M]; [96M]; [128M]; [160M].

DVMT Total Gfx Mem

Use this item to select DVMT 5.0 Total Graphic Memory size used by the Internal Graphics Device.

The optional settings: [128M]; [256M]; [MAX].

► **PCH-IO Configuration**

Press [Enter] to make settings for the following sub-items:

PCH-IO Configuration

HD Audio

Use this item to control Detection of the HD-Audio device.

The optional settings: [Disabled]; [Enabled].

[**Disabled**]: HDA will be unconditionally disabled.

[**Enabled**]: HAD will be unconditionally enabled.

Onboard Lan1 Controller

Use this item to control the PCI Express Root Port.

The optional settings: [Disabled]; [Enabled].

When set as [Enabled], the following sub-items shall appear:

Wake on LAN Enable

Use this item to enable/disable integrated LAN to wake the system.

The optional settings: [Disabled]; [Enabled].

Onboard Lan2 Controller

Use this item to enable or disable onboard NIC.

The optional settings: [Enabled]; [Disabled].

When set as [Enabled], the following sub-items shall appear:

System State After Power Failure

Use this item to specify what state to go to when power is re-applied after a power failure (G3 state).

The optional settings: [Always On]; [Always Off]; [Former State].

***Note:** The option [Always On] and [Former State] are affected by '**ERP Support**' function. Please disable ERP to support [Always On] and [Former State] function.

3-9 Security Menu

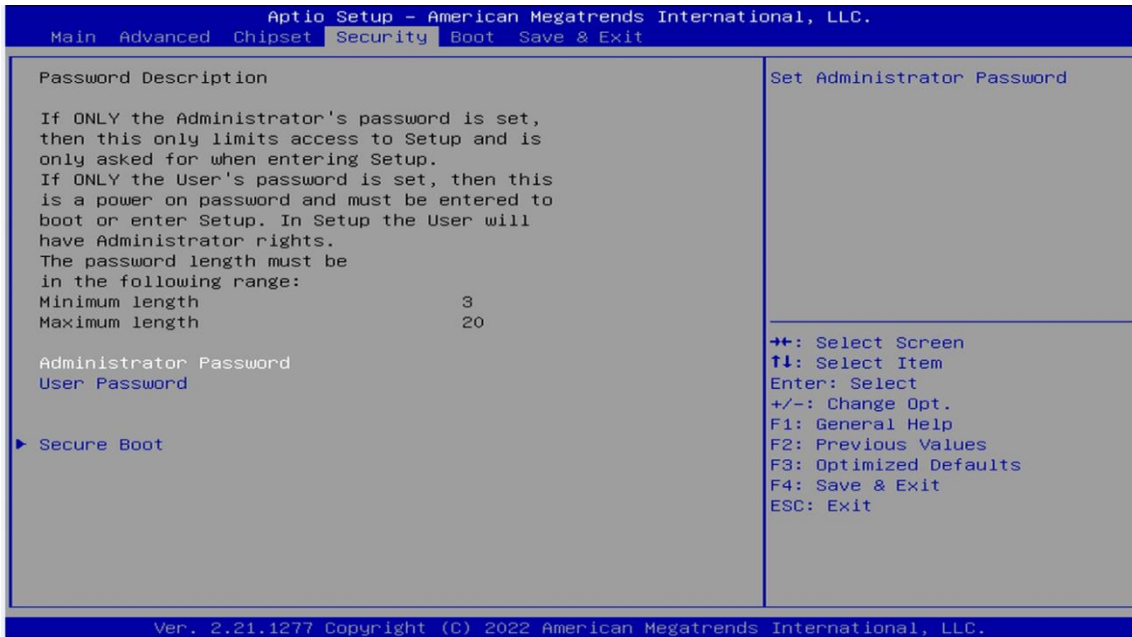

Security menu allow users to change administrator password and user password settings.

Administrator Password

If there is no password present on system, please press [Enter] to create new administrator password. If password is present on system, please press [Enter] to verify old password then to clear/change password. Press again to confirm the new administrator password.

User Password

If there is no password present on system, please press [Enter] to create new user password. If password is present on system, please press [Enter] to verify old password then to clear/change password. Press again to confirm the new user password.

▶ Secure Boot

Press [Enter] to make customized secure settings:

System Mode

Secure Boot

Secure Boot feature is Active if Secure Boot is Enabled, Platform Key(PK) is enrolled and the System is in User mode. The mode change requires platform reset.

The optional settings: [Disabled]; [Enabled].

No Active

Secure Boot Mode

Set UEFI Secure Boot Mode to Standard mode or Custom mode. This change is effective after save. After reset, this mode will return to Standard mode.

In Custom mode, Secure Boot Policy variables can be configured by a physically present user without full authentication.

The optional settings: [Standard]; [Custom].

When set as [**Custom**], user can make further settings in the following items that show up:

- ▶ **Restore Factory Keys**

Use this item to force system to User Mode, to install factory default Secure Boot key databases.

- ▶ **Reset To Setup Mode**

Use this item to Delete all secure boot key databases from NVRAM

- ▶ **Key Management**

This item enables expert users to modify Secure Boot Policy variables without full authentication, which includes the following items:

Vendor Keys

Factory Key Provision

This item is for user to install factory default Secure Boot keys after the platform reset and while the System is in Setup mode.

The optional settings: [Disabled]; [Enabled].

- ▶ **Restore Factory Keys**

Use this item to force system into User Mode. Install factory default Secure Boot key databases.

▶ **Reset To Setup Mode**

Use this item to Delete all Secure Boot key databases from NVRAM

▶ **Export Secure Boot variables**

Use this item to Copy NVRAM content of Secure Boot variables to files in a root folder on a file system device

▶ **Enroll Efi Image**

This item allows the image to run in Secure Boot mode.

Enroll SHA256 Hash certificate of a PE image into Authorized Signature Database (db).

Device Guard Ready

▶ **Remove 'UEFI CA' from DB**

Use this item to Device ready system must not list 'Microsoft UEFI CA' Certificate in Authorized Signature database (db).

▶ **Restore DB defaults**

Use this item to restore DB variable to factory defaults.

Secure Boot variable/Size/Keys/Key Source

▶ **Platform Key(PK)/Key Exchange Keys/Authorized Signatures/Forbidden Signatures/ Authorized TimeStamps/OsRecovery Signatures**

Use this item to enroll Factory Defaults or load certificates from a file:

1. Public Key Certificate:
 - a) EFI_SIGNATURE_LIST
 - b) EFI_CERT_X509 (DER)
 - c) EFI_CERT_RSA2048 (bin)
 - d) EFI_CERT_SHAXXX
2. Authenticated UEFI Variable
3. EFI PE/COFF Image (SHA256)

Key Source: Factory, External, Mixed.

3-10 Boot Menu

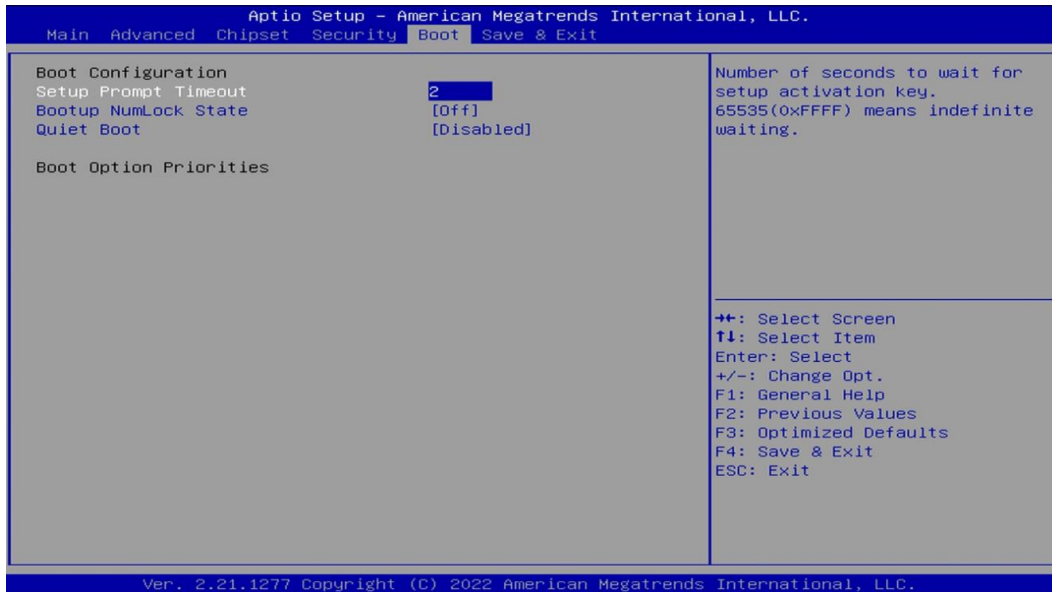

Boot Configuration

Setup Prompt Timeout

Use this item to set number of seconds to wait for setup activation key. 65535 (0xFFFF) means indefinite waiting.

Bootup NumLock State

Use this item to select keyboard NumLock state.

The optional settings: [On]; [Off].

Quiet Boot

The optional settings: [Disabled]; [Enabled].

Boot Option Priorities

3-11 Save & Exit Menu

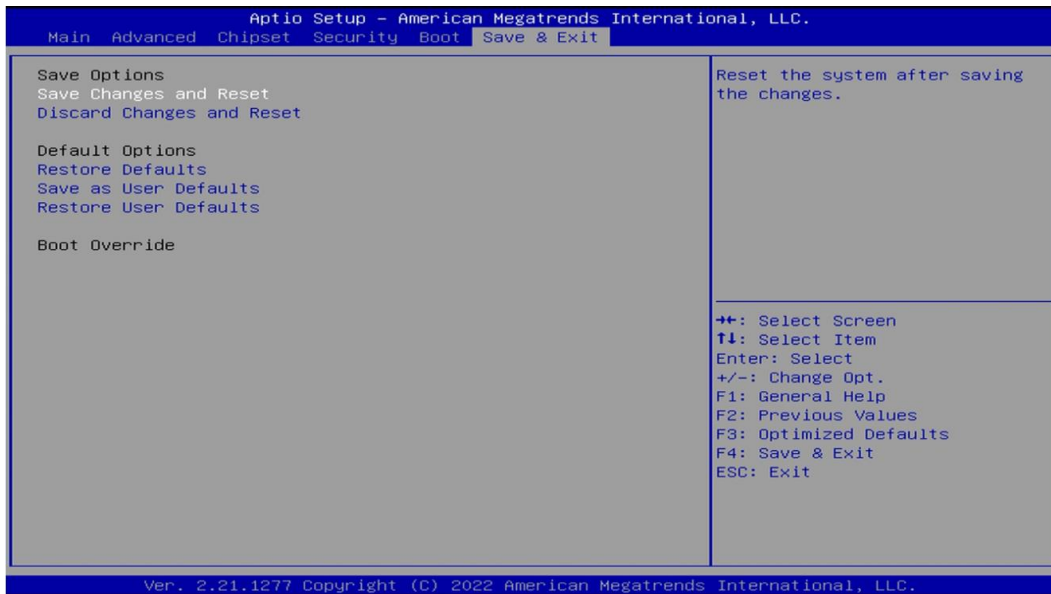

Save Options

Save Changes and Reset

This item allows user to reset the system after saving the changes.

Discard Changes and Reset

This item allows user to reset the system without saving any changes.

Default Options

Restore Defaults

Use this item to restore /load default values for all the setup options.

Save as User Defaults

Use this item to save the changes done so far as user defaults.

Restore User Defaults

Use this item to restore the user defaults to all the setup options.

Boot Override